

# Ultrasonic Sensors

Catalog Vol. 105



# Our Mission

To contribute to each customer's opportunity for success by fostering relationships that create the finest in world-class sensing and control solutions.



**These are the tenets that influence all of our actions as we fulfill our daily responsibilities.**

## Our Values

The manner in which we at Hyde Park go about accomplishing our mission is based upon inner values that guide us in our everyday business relationships to ensure the success of this company.

### Products

From our people come the finest quality products and the most effective solutions to our customers' needs. Our products are a reflection of our people.

### Profits

The final result of how well we serve our customers...the measure of our contribution to their opportunities for success...the requirement for survival and growth.

### Relationships

The uniqueness of Hyde Park stems, in large part, from the "partnering" relationships that exist between our customers, distributors, suppliers, and employees. From these relationships comes a synergism which is of mutual benefit to all.

### People

Our most valuable asset... the source of our ideas, energy, solutions, personality, and reputation.

## The Principles That Guide Us

- ◆ Loyalty to the customer first and foremost
- ◆ Product quality shall be at the highest possible level and never compromised
- ◆ Integrity is everything in all our relationships

**Corporate headquarters for Hyde Park Electronics... Builders of the world's finest ultrasonic sensors**

As a result of continued growth, spanning more than four decades, Hyde Park built a world-class corporate headquarters in Dayton, Ohio.

The facility houses all operations of the company including a research and development center. An advanced sensor applications laboratory and a customer applications training center provide distributors and customers, from all over the world, access to the most advanced, up-to-date technical information.

# Hyde Park Product Overview

## 18 mm and Dual-mount Ultrasonic Sensors

### VIRTU™ VM Series Sensors

The new sensor from Hyde Park featuring 18 mm or dual-mount body styles, a first for ultrasonics. Ranges up to 20 in. and available in connector or cable style. Small size makes it easy to mount in many applications.



## 12 mm and Flat-profile Ultrasonic Sensors

### SUPERPROX® SM300 Series Sensors

The world's first proximity sensor to offer an extended sensing range up to 102 mm (4") and detects objects of any material in harsh environments. Models available in either field programmable or fixed field from the factory.



## Ultrasonic Sensors

### SUPERPROX® SM500 Series Sensors

Easy push-button setup teach mode, sensing range up to 2 meters, operates in the harshest environments. Available versions include no delay, dual-level, on/off delay, synchronized and gate-controlled, container motion, and analog.



## 18 mm and Flat-profile Ultrasonic Sensors

### SUPERPROX® SM600 Series Sensors

Mounts easily in limited spaces, detects objects as small as 0.127 mm diameter, narrow beam, faster response. Available versions include small object, analog, and edge detection. Also available in stainless steel and plastic housing. The SM600FP package has DeviceNet communication capability.



## 30 mm Ultrasonic Sensors

### SUPERPROX® SM900 Series Sensors

Easy to mount, as powerful as larger SM500 series, factory configured to specific applications, with sensing ranges of 1, 2, and 8 meters. Versions include proximity with on/off output, dual-level, and analog output. The SM900 series also offers DeviceNet communication capability. Stainless steel-faced transducer, available for detection in severe, corrosive-type environments.



## Ultrasonic Counting Sensors

### SUPERPROX® CT1000 Series Counting Sensors

Counts separated, staggered, back-to-back, irregular shaped, and "patterned" bottles with a high degree of accuracy. Operates in the harshest environments.



# Hyde Park Product Overview (cont.)

## Configuration Package for Field Programming of SUPERPROX® Sensors

### SUPERPROX+™

Combined with the Model AC441A configurator interface allows user to load either standard or customer sensing configurations in to the SUPERPROX SC300FP, SC600, and the SC900 sensor series.



## Ultrasonic Thru-beam Sensors

### MICROSONIC® SM100 Series Sensors

Detects nearly any object, compatible with most logic systems, and programmable controllers, needs no sensitivity adjustments. Also available as a remote version.



## Ultrasonic Thru-beam Sensors

### MICROSONIC® SM400 Series Sensors

Our smallest thru-beam series to date, available in 12 mm threaded barrel and flat-profile housings. Mounts in limited space with sensing range up to 8 inches. Ideal for intricate edge and gap sensing applications. Fast response option available.



## Ultrasonic Thru-beam Sensors

### MICROSONIC® SM800 Series Sensors

Mounts in limited space, detects objects as small as 12.7 mm diameter, sensing range up to 40 inches. Small object version available. Also available in stainless steel and plastic housing.



## Web Inspection System

### MICROSONIC® SS100 Series Sensors & Controller

Detects broken plies, tears, or small holes, eliminates downtime, immune to changing colors or materials.



## Python Power

### AC/DC Power Supply/Output Converter

Accessory that allows a DC sensor to be installed where only AC power is available through an in-line AC/DC power supply and an integral TRIAC switch.



# Table of Contents

## INTRODUCTION

Product Overview _____	<b>i-ii</b>
Hyde Park Capabilities _____	<b>1-1</b>

## TECHNICAL SOLUTIONS OVERVIEW

Applications/Sensors _____	<b>2-1</b>
Product Applications _____	<b>2-3</b>
Formulas _____	<b>2-9</b>
Sensing Terms _____	<b>2-11</b>
Sensing Considerations _____	<b>2-23</b>

## VIRTU™ VM SERIES SENSORS

Model VM1 and VM18 Series, Proximity _____	<b>3-1</b>
--	------------

## SUPERPROX® PROXIMITY SENSORS

SUPERPROX 300 Series Introduction _____	<b>4-1</b>
Model SM300 Series, Proximity _____	<b>4-3</b>
Model SM302 Series, Dual-level _____	<b>4-11</b>
SUPERPROX 500 Series Introduction _____	<b>4-19</b>
Model SM500 Series, On/Off No Delay _____	<b>4-23</b>
Model SM502 Series, Dual-level/Latches _____	<b>4-31</b>
Model SM503 Series, On/Off with Delays _____	<b>4-41</b>
Model SM504 Series, Synchronized/Gate _____	<b>4-47</b>
Model SM505 Series, Proximity Motion _____	<b>4-53</b>
Model SM506 Series, Analog Output _____	<b>4-61</b>
SUPERPROX 600 Series Introduction _____	<b>4-71</b>
Model SM600 Series, Long-range Proximity _____	<b>4-73</b>
Model SM602 Series, Dual-level _____	<b>4-85</b>
Model SM606 Series, Analog Output _____	<b>4-93</b>
Model SM607 Series, Small-target Detection _____	<b>4-101</b>
SUPERPROX 900 Series Introduction _____	<b>4-107</b>
Model SM900 Series, Proximity _____	<b>4-111</b>
Model SM902 Series, Dual-level _____	<b>4-119</b>
Model SM906 Series, Analog Output _____	<b>4-129</b>
SUPERPROX Model CT1000 Counting Sensor _____	<b>4-139</b>
SUPERPROX+™ _____	<b>4-145</b>
SUPERPROX+ Software _____	<b>4-145</b>
SC Sensor Series _____	<b>4-146</b>
Model AC441A _____	<b>4-148</b>
DEVICENET™ _____	<b>4-149</b>

## MICROSONIC® THRU-BEAM SENSORS

MICROSONIC 100/400/700/800 Series Introduction _____	<b>5-1</b>
Model SM100 Series, Thru-beam Sensing _____	<b>5-3</b>
Model SM400 Series, Miniature Thru-beam Sensing _____	<b>5-13</b>
Model SM700 Series, Remote Thru-beam Sensing _____	<b>5-25</b>
Model SM800 Series, Miniature Thru-beam Sensing _____	<b>5-33</b>
Model SS100 Web Sensing System _____	<b>5-43</b>



# **Table of Contents, cont.**

## **PYTHON POWER™**

Python Power AC/DC Power Supply/Output Converter _____	<b>6-1</b>
--	------------

## **APPENDIX**

Accessories _____	<b>7-1</b>
Fax Form _____	<b>7-5</b>
Warranty _____	<b>7-6</b>

# Hyde Park Capabilities

For more than 40 years, Hyde Park has been refining ultrasonic technology and we've emerged as the world leader. In the beginning, we served primarily the container, food processing, beverage, and packaging industries. Today, we serve a broad spectrum of industries from automobiles to textiles, film to pharmaceuticals, soap powders to facial tissue... wherever there are requirements for efficient, high-speed machine or line control.

The reliability of Hyde Park ultrasonic sensors is unparalleled in the industry. Regardless of how hostile the environment, our ultrasonic sensors simply do not quit. Your line never goes down due to sensor failure. And they do not have to be replaced, unlike photoelectrics. Hyde Park ultrasonic sensors are not a commodity. They are an investment in a more cost-effective operation which translates to greater return on investment and increased profitability.

As for applications, we have the expertise to solve your sensing challenge with the right solution the first time, customized to your specific application. Hyde Park people are creative problem-solvers and offer customer service that cannot be matched. When you call Hyde Park you will not encounter

electronic menus or canned messages. You'll be able to talk to knowledgeable people eager to be of service in fulfilling your sensing needs.

## **Sensing... Ultrasonic Technology**

Sensing the object is the beginning of any high-speed machine control function...the higher the sensing reliability, the higher the efficiency of the control. Using the latest in ultrasonic technology, Hyde Park designs and manufactures reliable noncontact sensors for the most difficult applications. Depending on the application, Hyde Park offers variations of three sensing modes: proximity, retroreflective, and thru-beam.

## **Environmentally Reliable**

Completely self-contained and sealed, Hyde Park ultrasonic sensors are virtually unaffected by changing light conditions, colors, dust, splashing food, messy liquids, caustic cleaning

*Sensing Solutions You Can Trust...*

*Because We Build the World's Finest Ultrasonic Sensors*



**Facility**



**Testing**

**Facilities:** Our state-of-the-art facility.

**Testing:** Every Hyde Park sensor undergoes thorough testing before it is shipped to the customer.



solutions, frequent washdowns, and humidity. With other types of sensors, one or a combination of these conditions can cause unreliable sensing...resulting in periodic stopping to check, clean, and sometimes readjust the sensors.

### **Object Reliable**

For many conventional sensors, some objects are difficult to detect. This presents the possibility of false signals or no signals at all... resulting in erratic machine performance and production interruption. Because Hyde Park sensors utilize sound energy rather than light, they are reliable and effective in

detecting a variety of objects as small as 0.003 inch. Transparent or opaque, plastic or glass, metal or non-metal, uniquely shaped, different sizes or colors, green beans or soap powder... Hyde Park sensors detect them all.

### **Versatile, Fast, and Cost Effective**

Easy to set up and operate, and compatible with most logic systems and programmable controllers, Hyde Park ultrasonic sensors are used today to monitor all aspects of the production process while controlling machines running at speeds in excess of 2000

units per minute (upm). No need to use one type of sensor for one requirement, and a different type for another when chances are excellent you can save time and money by standardizing with Hyde Park sensors for all your sensing requirements. And, they are virtually maintenance free.

To meet the broad sensing requirements of the industries we serve, Hyde Park offers families of ultrasonic sensors, each one associated with a different sensing mode.



**Detail**

**Detail:** *Miniature circuit boards receive microscopic solders with the help of this 4X microscope.*

**Training:** *School of Sensing Solutions classes are an invaluable part of our Distributor Program.*

**Service:** *Real people offering real service.*

**Testing:** *Shield-room excludes ambient electromagnetic noise during product testing.*

**Training**



**Service**



**Testing**







**Inspection**



**Testing**



**Shipping**



**Design**



**Engineering**

**Inspection:** Circuit boards undergo stringent inspection before being approved for use in Hyde Park products.

**Shipping:** All labels and operating instructions are computerized to ensure accurate product information prior to shipment.

**Testing:** Ultrasonic sensors run overnight to assure full function in high temperature applications.

**Design:** Designing the right sensor for the job.

**Engineering:** Creative sensing solutions in the making.

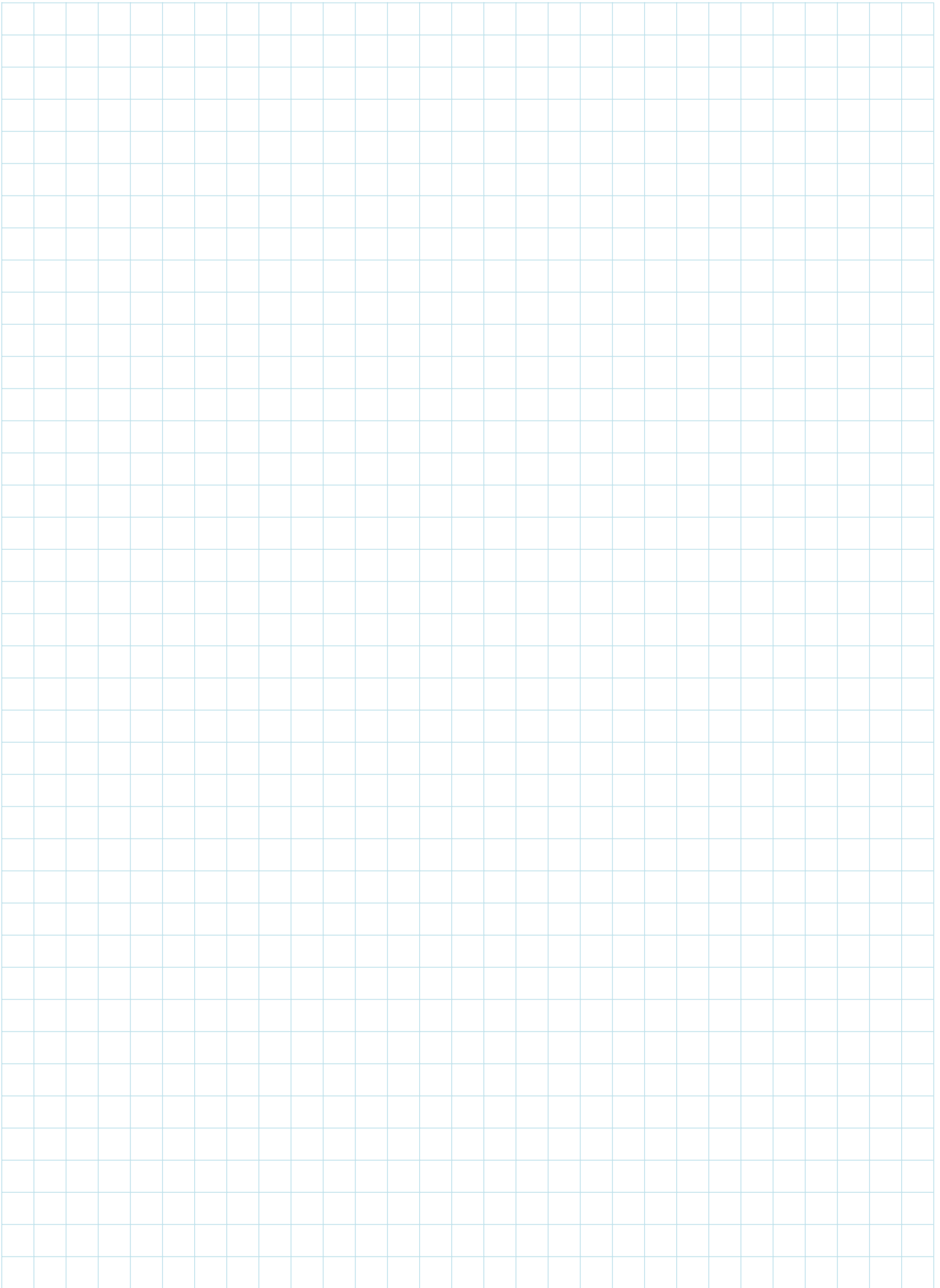

## Application

## Sensor

	VM1 & VM18	SM300 & FP	SM500	SM502	SM503	SM504	SM505	SM506	SM600	SM600FP	SM602	SM602FP	SM606	SM606FP	SM607	SM607FP	SM900	SM902	SM906	CT1000	SM100	SM700	SM800 & FP	SM400 & FP	SS100
Absence of objects	■	■	■		■	■			■	■					■	■	■				■	■	■	■	
All-materials detection in harsh environments	■	■	■	■	■	■	■	■	■	■	■	■	■	■	■	■	■	■	■	■	■	■	■	■	■
Backup detection	■	■	■		■				■	■							■				■	■	■	■	
Belt-position monitoring	■	■	■						■	■					■	■	■								
Bin-level detection				■				■			■	■						■	■						
Cap-in-proper-position detection		■																			■	■	■	■	■
Coding activation on paperboard cartons & cases	■	■	■		■				■	■							■				■	■	■	■	■
Coil (e.g., aluminum), end-of detection			■		■												■								
Container accumulation detection				■			■				■	■						■				■	■	■	■
Container counting																				■					
Container detection	■	■	■		■				■	■							■					■	■	■	■
Container detection at filler	■	■	■						■	■							■					■	■	■	■
Container indexing along a split conveyor into two separate lines	■	■	■						■	■							■					■	■	■	■
Container motion detection on mass-wide or single-file conveyors							■																		
Container orientation	■	■	■						■	■							■								
Container (including PET) detection for triggering laser marking printer	■	■	■		■		■		■	■							■								
Container (small) detection	■	■							■	■					■	■							■	■	■
Conveyor applications	■	■	■						■	■												■	■	■	■
Conveyor speed/product level (on conveyor belt) control								■					■	■					■						
Dancer loop monitoring and control				■				■			■	■							■	■					
Detection of jams on single-file conveyor				■	■						■	■							■						
Differential heights detection						■																			
Distance measuring								■					■	■						■					
Dough (in bin or hopper) level detection				■	■						■	■					■								
Down-container detection	■	■	■			■											■								
Edge detection															■	■									
Emptying process control including complete draw-down prevention				■							■	■							■						
End-of-line-stop detection	■	■	■					■	■							■									
Feeder bowl level detection & control				■				■			■	■	■	■					■	■					
Filler-level control				■				■			■	■	■	■					■	■					
Filling process control including overflow prevention					■						■	■								■					
Flow control of cans on mass conveyors							■	■												■					
Gap detection	■	■	■		■				■	■							■								
Gate-controlled sensing of multiple objects						■																			
Glue bead/drop detection		■													■	■									
Glue pot level (305°F) detection				■				■											■	■					
High-level-in-bin & alarm detection				■				■			■	■								■					
Ink level detection				■				■			■	■	■	■						■	■				
Jam detection	■	■			■	■															■				
Label (including edge) detection																■	■								

■ All sensors in series

# Application

# Sensor

	VM1 & VM18	SM300 & FP	SM500	SM502	SM503	SM504	SM505	SM506	SM600	SM600FP	SM602	SM602FP	SM606	SM606FP	SM607	SM607FP	SM900	SM902	SM906	CT-1000	SM100	SM700	SM800 & FP	SM400 & FP	SS-100
Large container detection	■	■																				■	■	■	■
Laser marking actuation on PET beverage containers	■	■			■		■		■	■													■	■	■
Lead edge detection				■											■	■			■			■	■	■	■
Level control in small vessels											■	■	■	■											
Liquid or slurry level				■				■			■	■	■	■					■	■					
Loop monitoring & control				■				■			■	■	■	■					■	■					
Low-level-in bin & alarm detection				■							■	■							■						
Maintaining a specific level in tanks & hoppers								■					■	■						■					
Mass-to-single-file container jam prevention detection				■							■	■							■						
Missing parts detection	■	■	■			■			■	■								■							
Missing ply detection																									■
Moving part (all materials) detection								■					■	■						■					
Object detection in severe, corrosive environments																		●							
Object-in-area detection	■	■	■			■			■	■									■						
Objects with round or irregular shapes and nonperpendicular profiles			■		■	■		■	■	■									■	■		■	■	■	■
Oil (hot/cold) level detection & control				■				■			■	■	■	■					■	■					
On-demand-controlled detection						■																			
Paper web control				■				■			■	■	■	■					■	■					
Part-to-part distinguishing	■	■	■			■			■	■								■							
Plastic extrusion detection	■	■	■						■	■							■					■	■	■	■
Proximity/Position-of-object detection	■	■	■					■	■	■			■	■	■	■	■			■					
Ply break																									■
Roll-diameter monitoring & control								■					■	■						■					
Roll (end of) detection	■	■	■		■			■	■	■			■	■				■		■					
Roll-speed monitoring & control								■					■	■						■					
Seal (foil/tamper-proof/safety) detection														■	■										
Seam/splice detection																									■
Severe, corrosive chemical level monitoring and control																			●	●					
Silo (tall tank) level detection																				▲	▲				
Small-container detection	■	■							■	■													■	■	
Soap extrusion								■					■	■						■					
Solid (grain, vegetables, soap, powder, chips) levels				■				■			■	■	■	■					■	■					
Synchronized sensing of multiple objects						■																			
Tank level alarm detection				■				■			■	■								■					
Tension monitoring & control				■				■			■	■	■	■					■	■					
Thin wire, thread detection															■	■									
Valve (electro-mechanical) monitoring & control								■					■	■						■					
Variable-speed motors & pumps modulation								■												■					
Vehicle detection																				▲					
Web break/hole detection	■	■	■						■	■									■			■	■	■	■
Web loop (e.g., paper) control								■					■	■						■					

- All sensors in series
- ▲ SUPERPROX SM900 long range series with range up to 8 m (26')
- SUPERPROX SM900 stainless steel-faced transducer series

Note: This list is but a sampling of the many applications in which Hyde Park's ultrasonic sensors are an effective solution. For assistance in determining the proper sensor for a given application, please call your Hyde Park distributor or Hyde Park Electronics today.

## Feeder Bowl Supply Control

**SUPERPROX® SM503 Series**

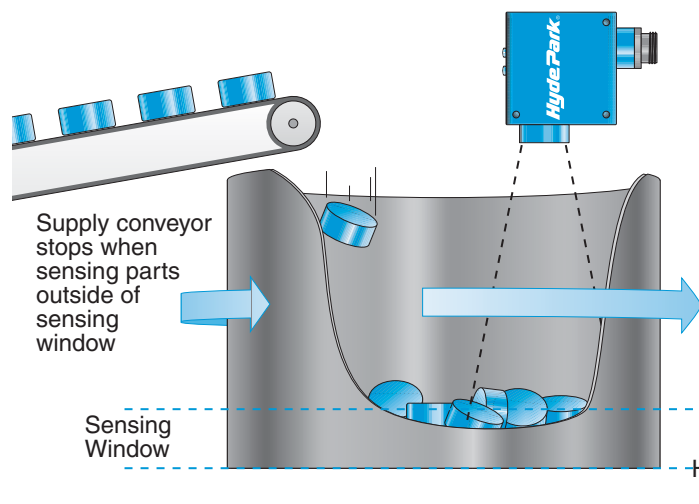

## Dual Level High-Low Latch Control Detection of Liquids

**SUPERPROX SM902A-8 Series**

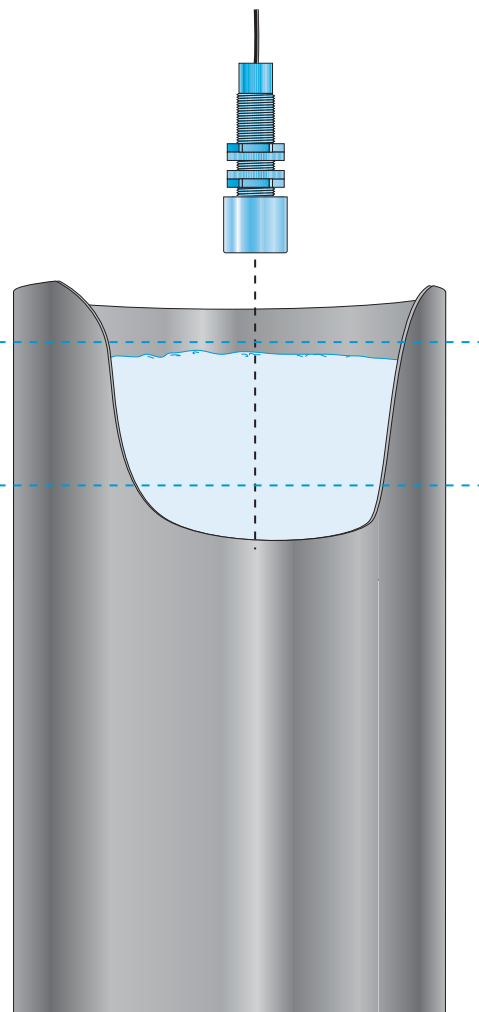

## Conveyor Jam & Backup Detection

**SUPERPROX SM503 Series**

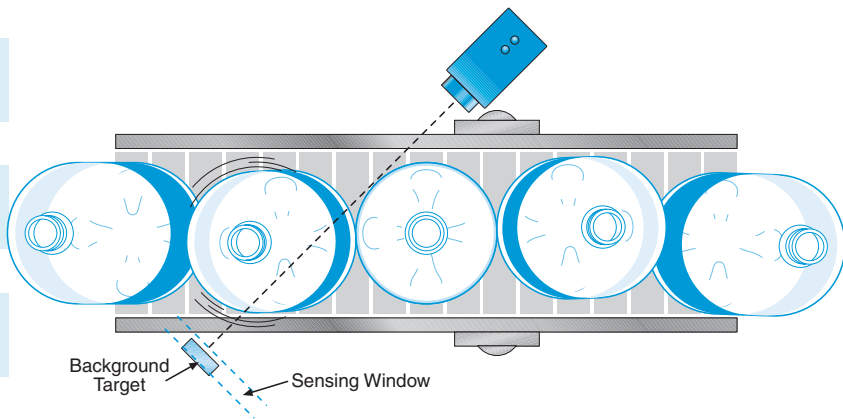

## Web Process Control Sensing Functions

Continuous or Two-Point Tension Control  
**SUPERPROX SM502 & SM506 Series**

(Sensors can be mounted on top or bottom side of loop)

Broken Web Detection  
**SUPERPROX SM500 & SM503 Series**

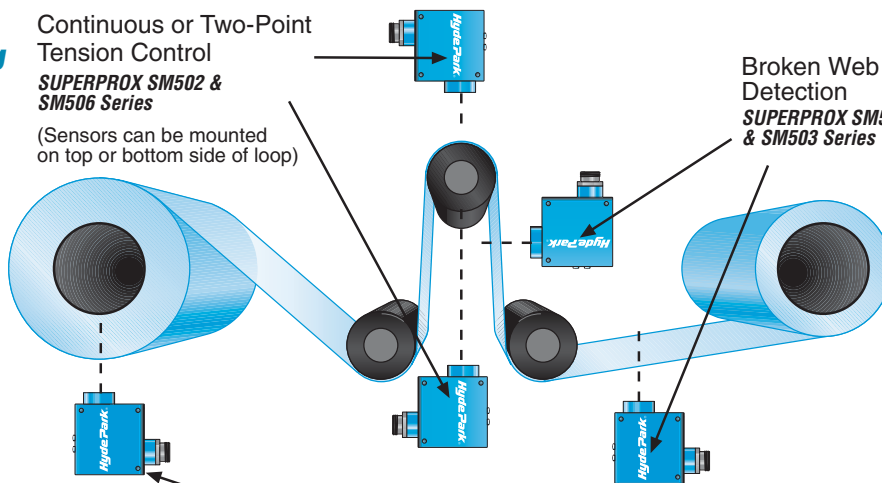

**SUPERPROX SM506** for Roll Diameter Monitoring and  
**SUPERPROX SM500** for End of Roll Detection

## Broken Ply Detection

MICROSONIC® SS100 System

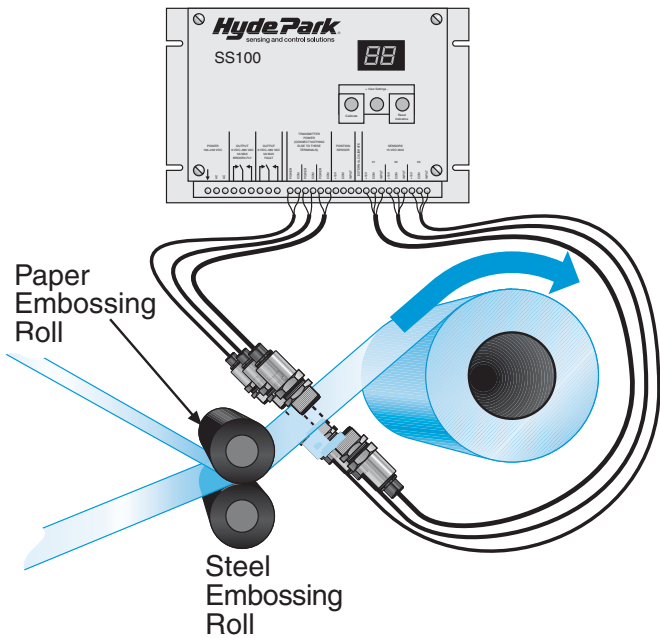

## High Level Detection

SUPERPROX® SM902A-8 Series

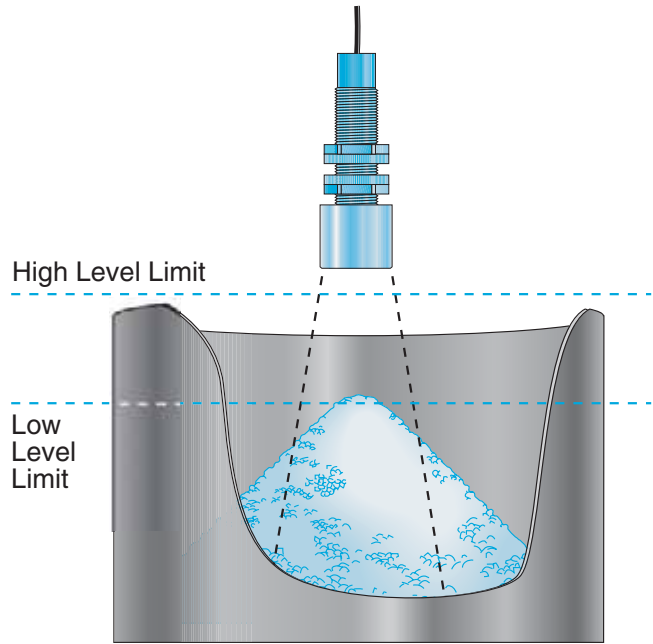

## Label Edge Detection on Carrier Web

SUPERPROX SM607 Series

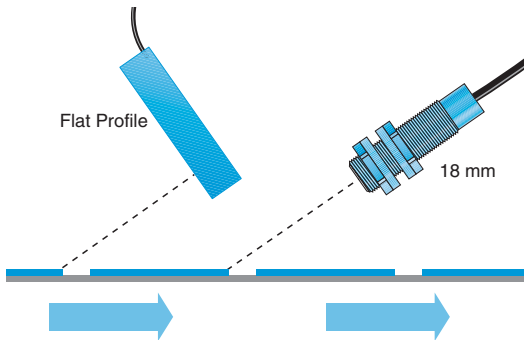

## Accurate High Speed Counting of Cylindrical Clear Objects

MICROSONIC SM100 & SM800 Series

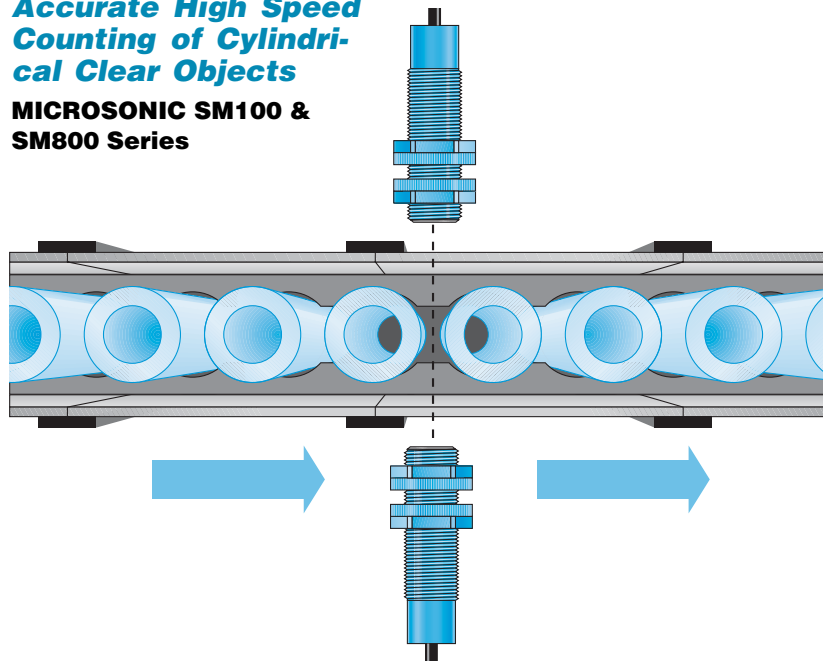

## Glue Bead Detection

SUPERPROX SM607 Series

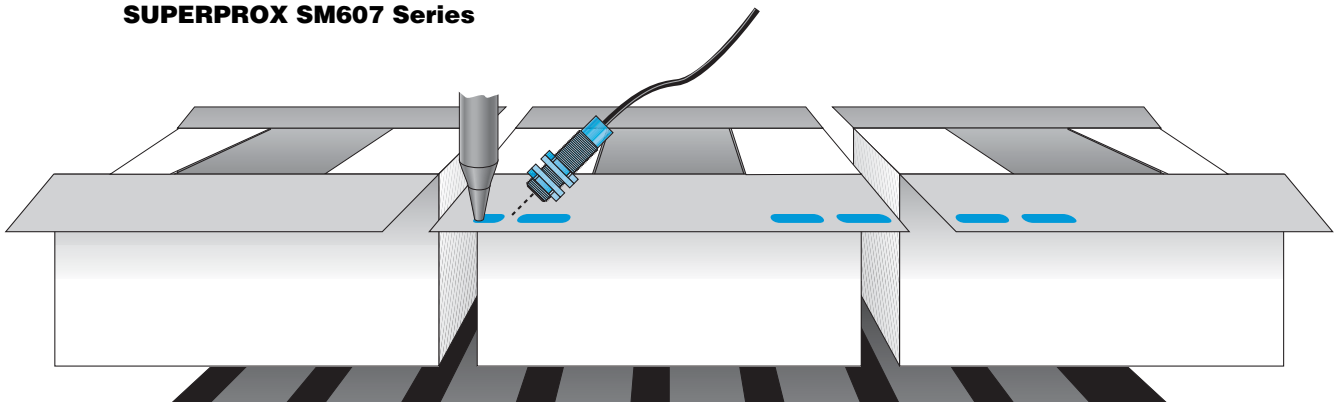

**Clear Bottle Detection**  
*For Friendlier Environments*

**SUPERPROX®**  
**SM600 Series**

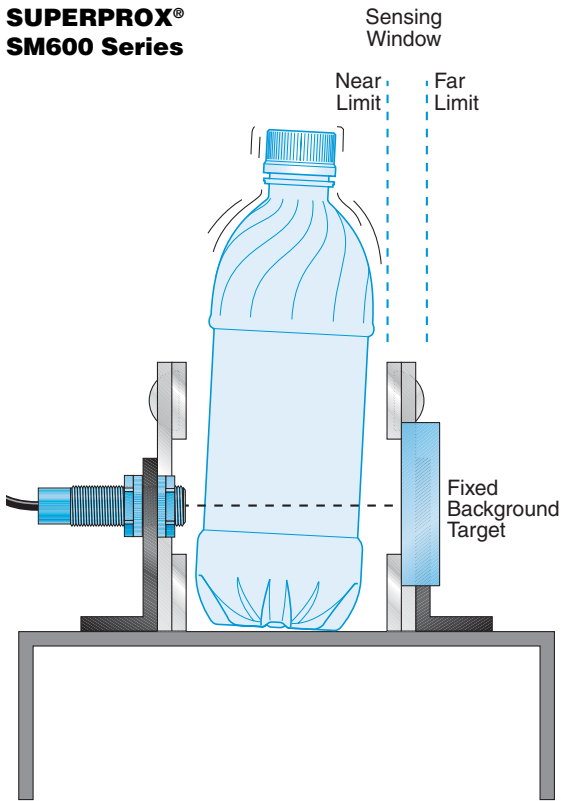

**Full or Empty Case Inspection**  
**SUPERPROX SM504 Series**

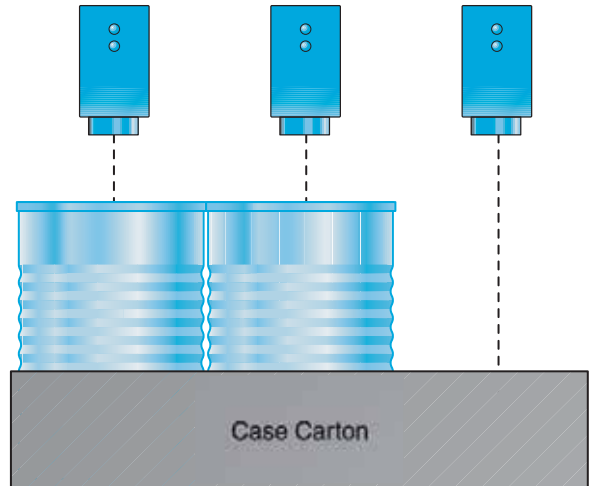

**Broken Wire/Thread Detection**  
**SUPERPROX SM607 Series**

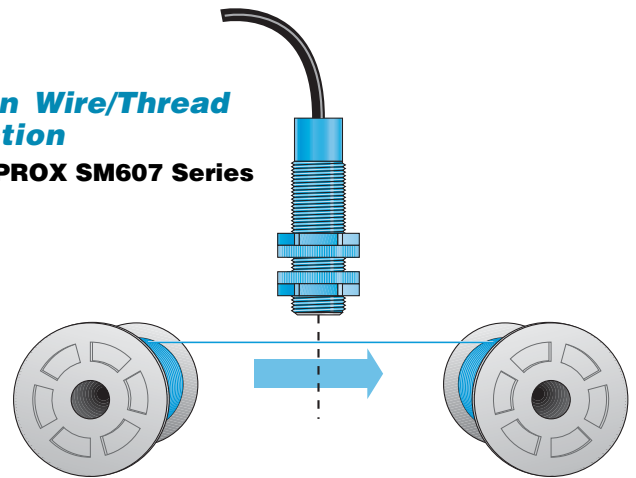

**Trigger or Gate-Control & Backup Detection**

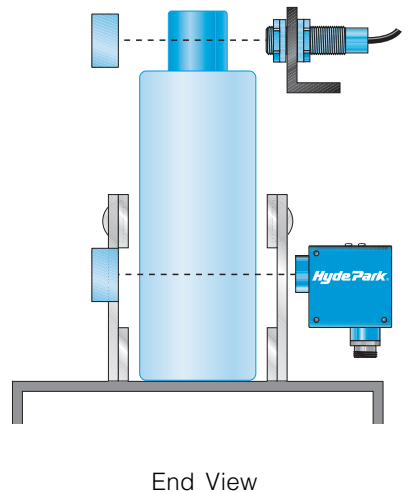
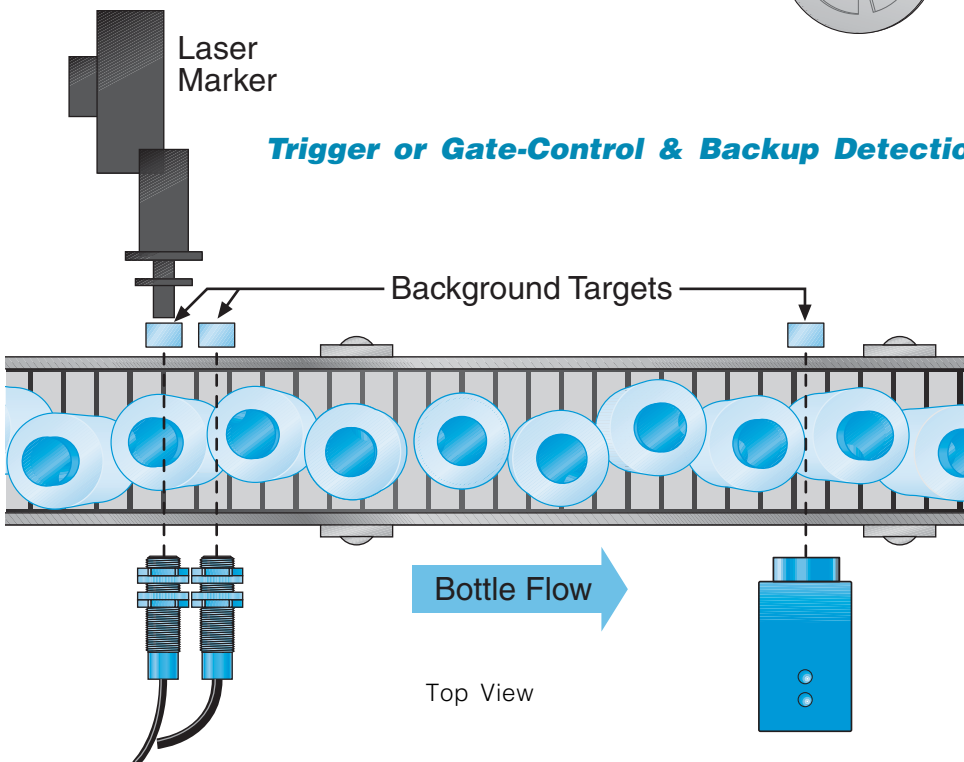

**SUPERPROX SM600 Series**

**SUPERPROX SM505 Series**  
**Motion Detection Sensor**

**Missing Cap Detection  
Low Cap Supply  
Automatically Stops Filler  
and Capper**  
**SUPERPROX® SM300 Series**

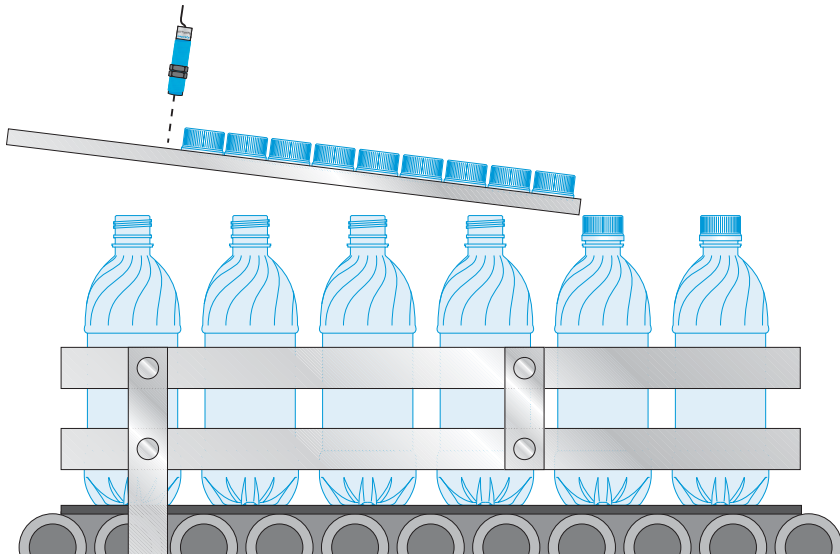

**Dual Level High-Low Latch  
Control Detection**

**SUPERPROX SM902A-8 Series**

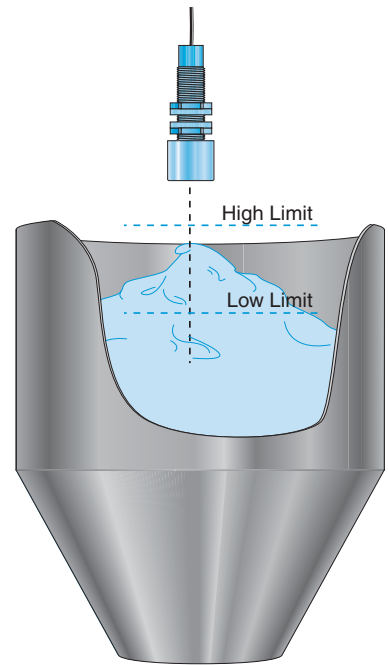

**Continuous Level  
Monitoring**

**SUPERPROX SM606 Series  
Analog Output Sensor**

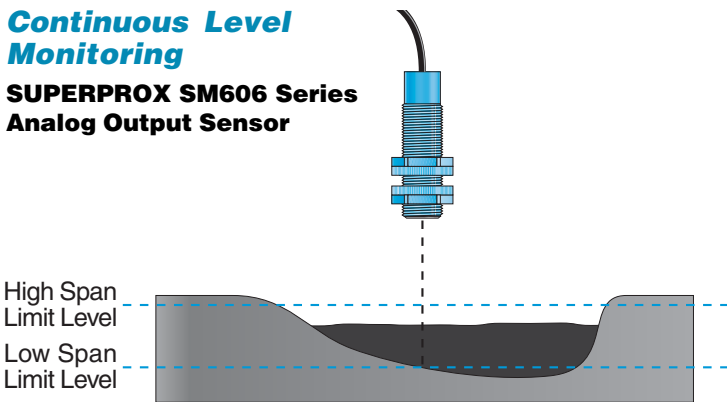

**Lead Edge or Backup Detec-  
tion**

**MICROSONIC SM100 or SM800 Series**

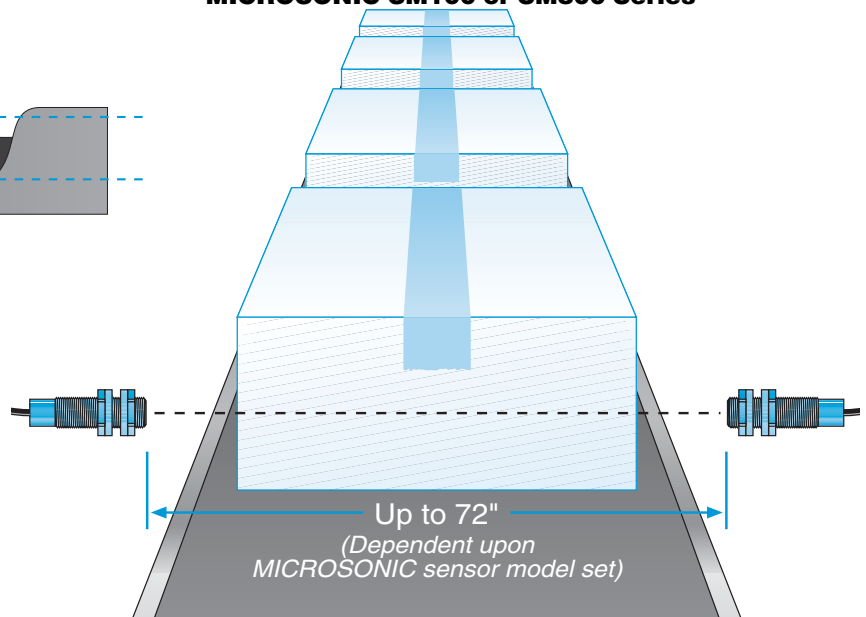

**Clear Bottle Detection**

**Hostile or  
Severe-Duty  
Environments**

**MICROSONIC®  
Thru-beam  
Sensors**

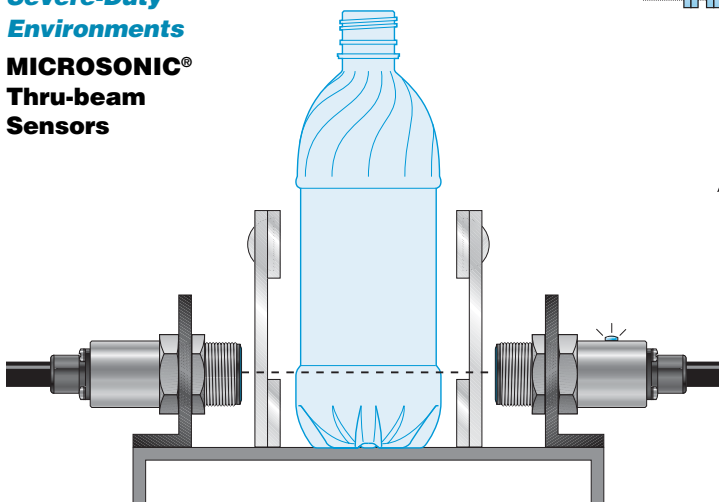



**Container Detection**  
**SUPERPROX SM300FP Series**

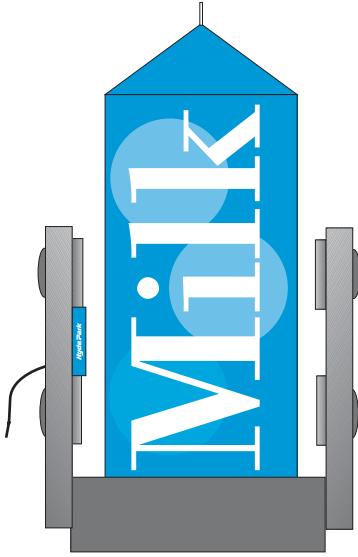

**Metal Material Detection**  
**SUPERPROX SM300 Series**

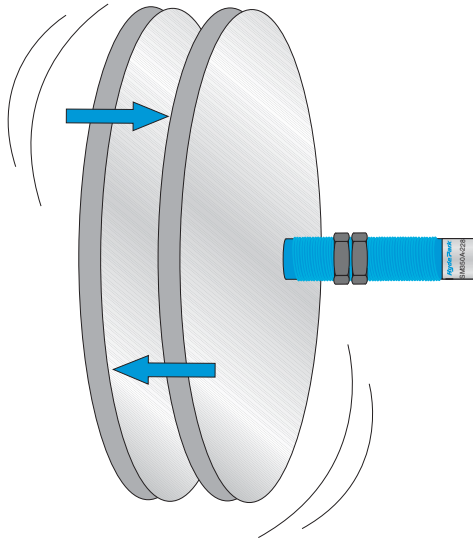

**Missing Cap Detection**  
**SUPERPROX SM300 Series**

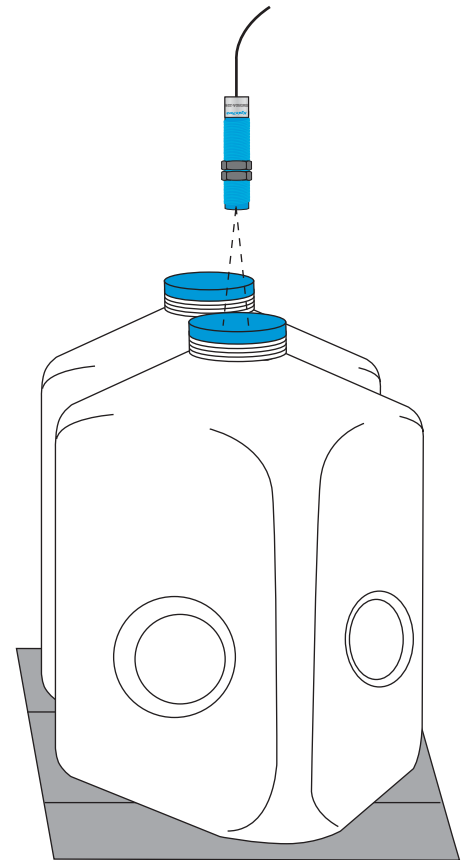

**Clear Web Detection**  
**SUPERPROX SM300 Series**

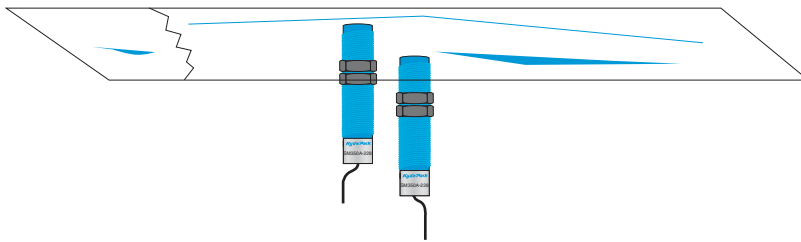

**Container Detection**  
**SUPERPROX SM600FP Series**

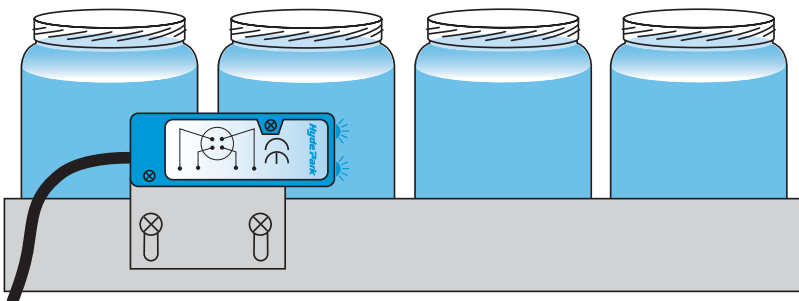

**Clear Cellophane Panel Detection**  
**SUPERPROX SM300FP Series**

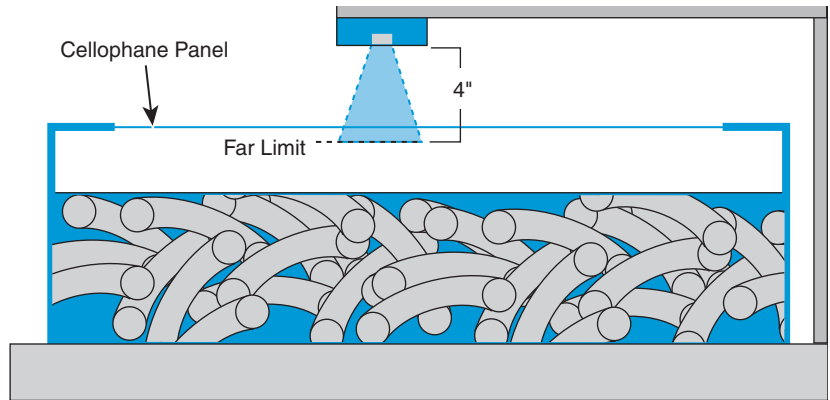

**Single Filer Jam Protection**  
**SUPERPROX® Model SM5X2X-114**  
**Dual Level Latch Control Sensor**

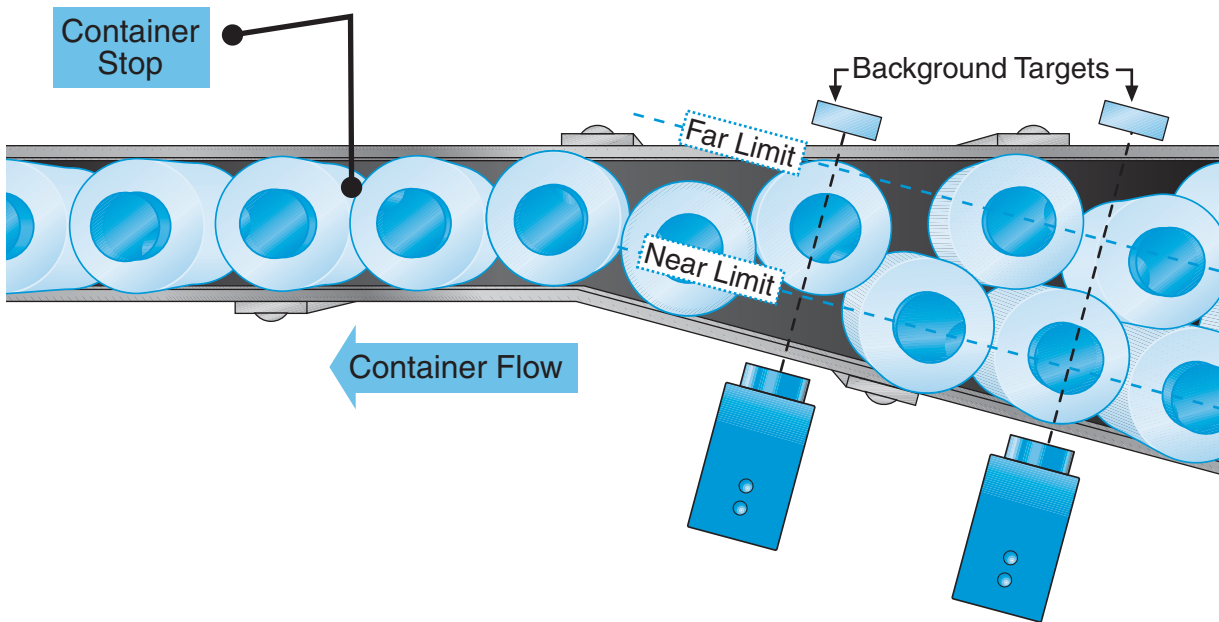

**Single File Conveyor Container Counting**  
**SUPERPROX® CT1500 Series**

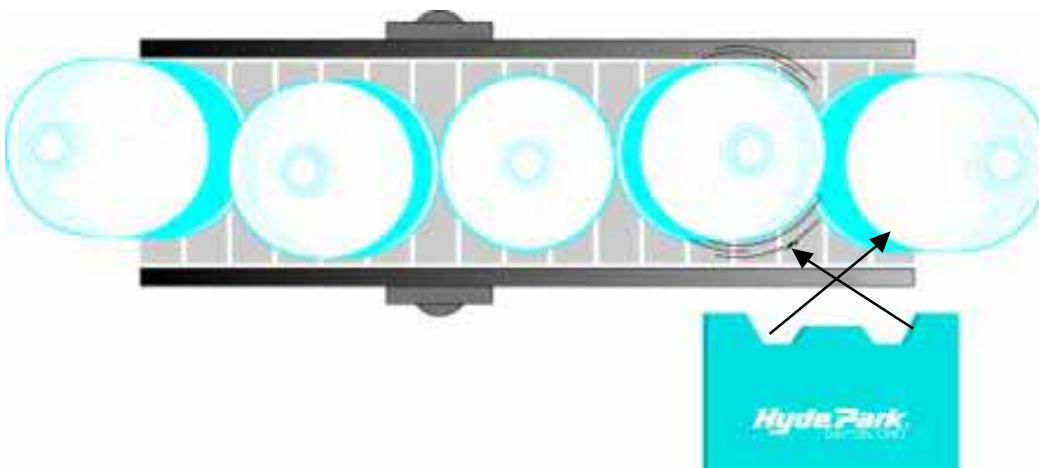

## To Calculate:

Maximum container rate (MCR) on conveyor in containers per minute

Given: CP = container pitch (container-to-container spacing) in inches  
 RP = recommended sample pitch (distance resolution) in inches  
 SP = sampling period of sensor (cycle time) in seconds

Formula:  $\frac{RP \times 60 \text{ seconds}}{CP \times SP} = \text{MCR containers per minute}$

Example: CP = 4 inches  
 RP = 0.25 inch  
 SP = 0.003 seconds

Calculation:  $\frac{0.25 \times 60 \text{ seconds}}{4 \times 0.003} = 1250 \text{ containers per minute}$

## To Calculate:

Required sensor sample period (SP)

Given: CS = conveyor speed in inches per second  
 RP = recommended sample pitch (distance resolution) in inches

Formula:  $\frac{RP}{CS} = \text{SP seconds}$

Example: CS = 100 inches/sec.  
 RP = 0.25 inches

Calculation:  $\frac{0.25}{100} = 0.0025 \text{ sec. (or 2.5ms)}$

## To Calculate:

Sample pitch (SD) or distance between samples

Given: CS = conveyor speed in inches per second  
 SP = sensor sample period in seconds

Formula:  $CS \times SP = \text{SD inches}$

Example: CS = 100 inches/sec.  
 SP = .0005 seconds

Calculation:  $100 \times .0005 = .05 \text{ inches}$

## To Calculate:

Window edge drift (WS) due to temperature change.  
 (SM600, SM607 only. SM606 is temperature compensated)

Given: The window edges will drift at the rate of 1.7% per 10°C  
 WE = window edge in question given as distance from sensor face in inches  
 TD = temperature shift in degrees Celsius

Formula:  $\frac{0.017 \times TD \times WE}{10} = \text{WS in inches}$

Example: WE = 2 inches  
 TD = 20°C

Calculation:  $\frac{0.017 \times 20 \times 2}{10} = .068 \text{ inches}$

Note: The speed of sound increases as the temperature rises therefore the window edges will appear to move toward the sensor as the temperature increases.

## To Calculate:

Object distance (D) from inner window edge using 0-10V analog sensor, indirect type.

Given: VOUT = output in volts  
 WW = window width in inches

Formula:  $\frac{VOUT \times WW}{10} = \text{D in inches}$

Example: VOUT = 3.3 volts  
 WW = 4.625 inches

Calculation:  $\frac{3.3 \times 4.625}{10} = 1.526 \text{ inches from the inside window edge}$

---

## Formulas, con't

### To Calculate:

Object distance (D) from inner window edge using 4-20mA analog, indirect type sensor.

Given: IOUT = output in milli-Amps  
WW = window width in inches

Formula:  $\frac{(IOUT-4) \times WW}{16} = D$  in inches

Example: IOUT = 15mA  
WW = 4.625 inches

Calculation:  $\frac{(15-4) \times 4.625}{16} = 3.18$  inches from the inside window edge

---

### To Calculate:

Sonic beam diameter (D)\*

Given: L = distance of sensor in inches  
BS = beam spread in degrees

Formula:  $2 \times L \times \tan(BS/2) = D$  in inches

Example: L = 4 inches  
BS = 7 degrees (SM600)

Calculation:  $2 \times 4 \times \tan(7/2) = 0.489$  inch diameter

\*NOTE: Since the beam spread in degrees changes with distance from the sensor, this calculation is approximate. For more accurate calculation, ask your distributor or Hyde Park for a beam plot.

---

### To Calculate:

Minimum hole-size diameter (D) through which to detect\*

Given: L = distance of hole from sensor in inches  
BS = beam spread in degrees  
S = safety factor

Formula:  $S \times 2 \times L \times \tan(BS/2) = D$  in inches

Example: L = 4 inches  
BS = 7 degrees (SM600)  
S = 1.2 (20% safety factor)

Calculation:  $1.2 \times 2 \times 4 \tan(7/2) = 0.587$  inch diameter

\*NOTE: Since the beam spread in degrees changes with distance from the sensor, this calculation is approximate. For more accurate calculation, ask your distributor or Hyde Park for a beam plot.

---

## absorbent materials

Those object materials that absorb some or all of the transmitted ultrasonic energy rather than reflect it back to the sensor. For example, granular products, foam rubber materials, and certain textiles and papers may need a stronger transmitted signal for reliable detection. Detection of foam surfaces from soaps and similar products is also difficult and should be tested prior to installation.

## accuracy

In ultrasonic analog sensing specifications, it is the relationship between output magnitude and actual object position, expressed in terms of the span. Using the Model SM506 analog sensor with a 4 to 20 mA output as an example: If the sensor is set up with a 20" span between the near and far limit and the sensor's output current reads 12 mA, the object is expected to be 10" from the near limit. The accuracy specification indicates a possible maximum object position error of  $\pm 0.50\%$  of the span, or 0.1" ( $0.005 \times 20$ ). This means the distance at 12 mA can vary between 9.9" and 10.1" in that span.

## acoustic interference

An intense acoustical noise generated near the sensor which may interfere with the sensor's operation. Offending noise sources are usually well above the range of hearing. Common sources of this type of acoustical interference may be: air nozzles, machine vibration, and sliding friction. Another source of acoustic interference, known as "cross talk," can result when an ultrasonic sensor responds to the signal from an adjacent ultrasonic sensor. While this can be eliminated by repositioning the sensors, the Hyde Park SUPERPROX® Model SM504 sensors are designed to operate adjacent to other SM504 sensors without cross talk interference.

## air movement and densities

See *Sensing Considerations* section on 2-23.

## air pressure

See *Sensing Considerations* section on 2-23.

## ALARMS push-button

A push-button on the alarm models of the Hyde Park SUPERPROX® Model SM500 family of sensors is used to set two discrete alarm set points (near/far, high/low) anywhere within the sensing range where alarm outputs are required to protect equipment from potential damage. The Model SM502 dual-level series and SM506 analog series have this push-button.

## ALARM set point

In using either the Hyde Park Model SM502/602/902 dual-level or SM506 analog series sensors, the point within the sensing range where an alarm output is generated.

## alignment

The positioning of a sensor so that the maximum amount of the emitted sound energy reaches the receiving sensor. For pulse-echo types of sensors in object and background mode, the transmitted beam of the sensor should be perpendicular to the object or background target, respectively. For thru-beam

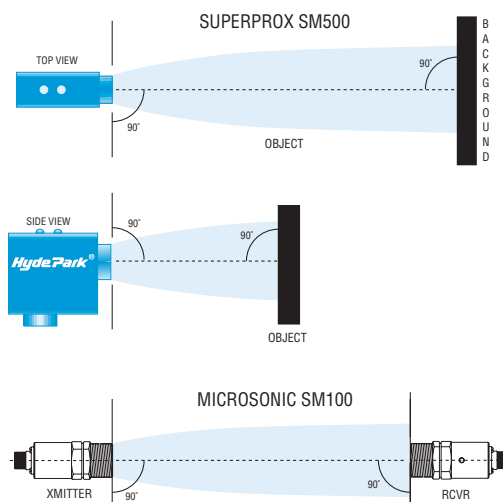

types of sensors, alignment refers to the extent to which a line, perpendicular to the face of both transmitter and receiver, passes through the center of each face. In some situations, perfect alignment is not desirable and better results are obtained if the receiver is tilted about 10 degrees out of alignment.

## alternating current (AC)

An electric current that periodically reverses direction of electron flow. The rate at which a full cycle occurs in a given unit of time (usually a second) is called the frequency of the current. A sinusoidal current rated at a given frequency, usually 50 Hz or 60 Hz.

## ambient

The environmental conditions in and around the sensing area (e.g., humidity, light intensity, temperature, air speed).

## ambient acoustical noise

See *Sensing Considerations* section on 2-23.

## ambient temperature

The temperature (in Centigrade or Fahrenheit) of the environment in which the sensor is operating.

## ampere (Amp)

A standard unit of current. It is defined as the amount of current that flows when one volt of emf (electromotive force) is applied across one Ohm of resistance. An Ampere of current is produced by one Coulomb of charge passing a point in one second.

## analog

A representation of data by continuously variable quantities, e.g., voltage or current.

## analog limits

In Hyde Park's analog sensors, the near and far boundaries that are set with the LIMITS push-button, within which the

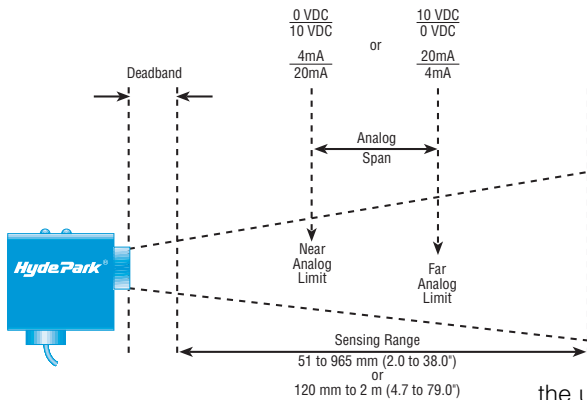

object detection and control takes place. In the SUPERPROX® Model SM506 series, these limits are identified by the analog output selected: 0 to 10 VDC or 4 to 20 mA. The position of maximum output is determined by the configuration Switch 1 position. In the DIR position, the maximum analog output occurs at the limit (Near) closest to the sensor. In the INV position, the maximum analog output occurs at the limit (Far) farthest from the sensor.

## analog response

The speed at which the continuously variable quantity (output voltage or current) follows the object position. Two methods are typically used to measure this: step response and frequency response. Step response is the time (typically in ms) required for the voltage or current to change to a certain percent of the final value. Frequency response is another way to measure analog response. Imagine a SUPERPROX® analog sensor monitoring a rotating cam. As the cam rotates faster and faster, the unit becomes less accurate in its measurement. The frequency where the measured value of the difference between minimum and maximum is one-half the true difference is often used as a measure of frequency response. In Hyde Park's analog sensors, it is the change in analog output relative to the change in position of an object sensed within the near and far span limits of the Model SM506 or SM606 series.

## attenuation

The lessening of sensing energy caused by environmental elements such as dirt, dust, moisture, or other contaminants in the sensing area. Attenuation is measured as a ratio or as the logarithm of a ratio (decibel).

## background sensing mode

For Hyde Park's SUPERPROX® ultrasonic sensors, this sensing mode is recommended when detecting objects with round or irregular shapes and non-perpendicular profiles. The background mode, using a unique secondary echo lock-out function, enables the sensor, with a fixed, background target, to operate as a universal, all-materials-type, break-beam detector.

After setting the window limits on the fixed target (See Figure 1 below), make sure the ultrasonic transmission path between the sensor and the target is clear of obstructions.

Once set, the sensor accepts only the first (primary) ultrasonic pulse echo received from the target within the window limits as shown in Figures 1 and 2. In this mode, the echo is received and detected as an object not present. Object presence is detected when the object interrupts the sonic pulse

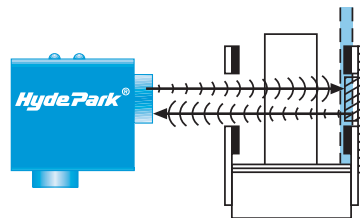

Figure 1

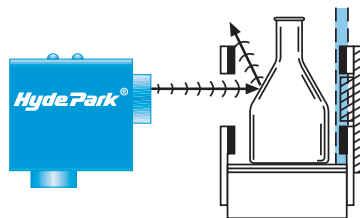

Figure 2

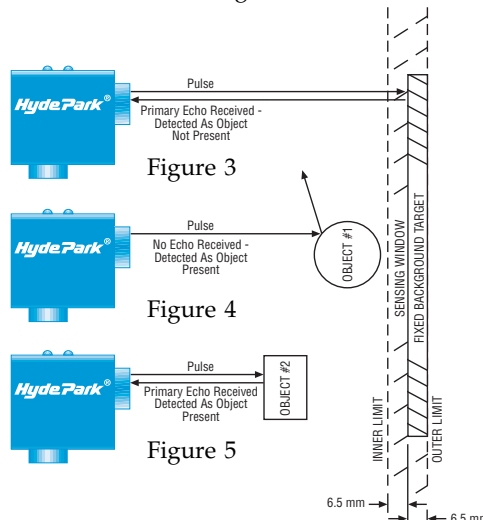

Figure 3

Figure 4

Figure 5

transmission path between the sensor and the fixed target, as shown in Figures 2, 4, and 5.

As a result of the secondary lock-out function, the sensor is permitted to receive only the primary echo after each sonic pulse. All subsequent secondary echoes are "locked out". If the first echo received from the object travels a lesser distance than the first echo from the fixed target window, that object is detected as being present.

As shown, if the echo off an object is not received (Object #1, Figure 4), or if the first echo is received off an object that is outside the window limits (Object #2, Figure 5), the object is detected as being present.

## background suppression

An ultrasonic sensor's capability to disregard any or all pulse-echo returns from objects located outside or beyond where the far sensing window limit is set.

## backup detection

An application in which the sensor is used to detect either the presence of objects (e.g., containers, that have accumulated at a particular point in the conveyor line) or when the movement of back-to-back containers is such that a backup condition is determined.

## beam

Ultrasonic waves emitted from the sensor's transmitter. The waves diverge, approximating a cone shape until environmental attenuation "pinches off" the cone. The beam cone angle is included in the sensor's specification.

## beam angle

The angle at which the pulses of sound energy expand from the transmitter, thus defining the cone of the sonic beam. Illustrated below are angle A of 20° for the Hyde Park Model SM500 2 meter

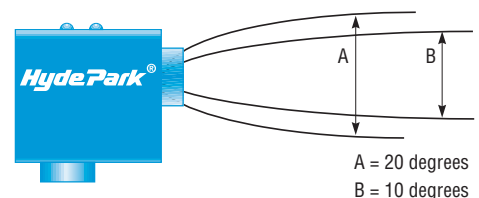

range series and angle B of 10° for the SM500 1 meter range series. The stated included angle of the Hyde Park sensors' sonic beams ranges from 7° to 20° depending upon the model and is only an approximation. The beam plot (shown on next page) of a particular sensor model provides more accurate information.

## beam plot

Developed from data collected at 20° C, zero air flow, the points defining the boundaries and shape of the Hyde Park sonic beam. Below is shown the beam plot for the SM606 analog sensor. The boundaries were established using a 10 cm x 10 cm (3.94" x 3.94") object "target" positioned parallel to the sensor

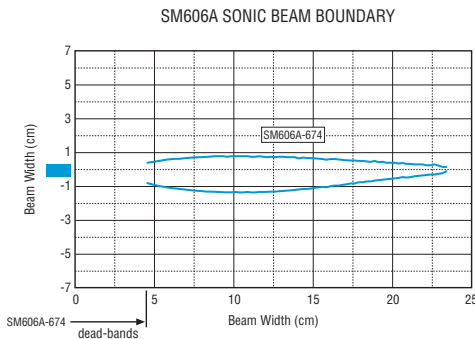

face. The plot is valid for targets equal to or larger than 10 cm x 10 cm. Points defining the boundaries of the plot are represented by the target edge closest to the beam axis. These and other plots are available from Hyde Park upon request.

## break-beam sensing

See *thru-beam sensing* on 2-20.

## "CE" mark

The CE mark on Hyde Park sensor products indicates a guarantee of conformity to entry requirements for products sold in the European market.

## chemical compatibility

The capability of a sensor to avoid damage to its components caused by chemicals. Hyde Park's SUPERPROX® and MICROSONIC® ultrasonic sensors will resist most chemicals including most food/beverage products. An optional fluorosilicone rubber face is available to resist petroleum-based hydrocarbons and a variety of other chemicals.

## coincidental secondary echo condition

This is a condition associated with using the Hyde Park SUPERPROX® proximity sensor in the object mode (Figure 1, next column).

When an object is properly positioned between the sensor and the window (See Figures 2 and 3), the ultrasonic pulse from the sensor will reflect repeatedly between the sensor and the object, thus creating a series of secondary echoes. A coincidental secondary echo condition exists when the distance traveled by the primary echo of an object at or within the window limits is a

multiple of (most likely twice) the distance traveled by a secondary echo off the foreground object. As shown in Figure 3, Object #3 is properly positioned halfway between the sensor

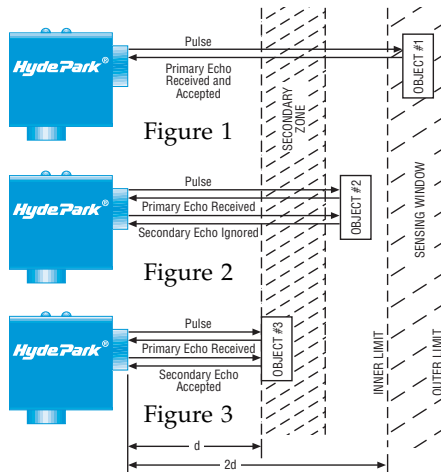

and the inner window limit and is mistakenly detected as if it were Object #1. Exercise caution when considering a SUPERPROX® application to avoid this "false echo" condition.

## common

A circuit ground, the return path of charge to a power supply. Frequently, this point has the same potential (voltage) as a true earth ground, but this is not guaranteed.

## cone diameter

The diameter of the sonic beam cross section at a specific distance out from the sensor and beyond the deadband.

## configuration switches

A set of dip switches, located in the control compartment of the large SUPERPROX® ultrasonic sensors, used to set up the sensor for its intended application. See the Product Information section.

## connector

A device used to join or break two circuits easily and when required. Also, a Hyde Park sensor connection style that provides a quick connect and disconnect service for the user.

## continuous load current

The flow of charge from an output to an external unit.

## continuous wave

The type of ultrasonic sensing used in Hyde Park's MICROSONIC® thru-beam sensors in which a separate transmitter generates ultrasonic energy continuously with very short interruptions of the transmitter beam easily detected by a separate and

properly aligned receiver. See *thru-beam (or break-beam) sensing* on page 2-20.

## control compartment

The area in the back of the SUPERPROX® Model SM500 family sensors, behind the square cover, that contains a variety of configuration switches, push-buttons, and a potentiometer used to set up the sensor for a given application. See Product Information section.

## coupler

The silicone material, which when attached to the piezoelectric crystal in the Hyde Park sensor, serves as the face of the sensor and is used to amplify the sound wave signal and "push" it through the air. This coupler provides a link that transports the sound energy or signal from the crystal to the outside air. This is necessary because air presents a resistance that would greatly inhibit the sensing range were it not for the boost provided by the silicone coupler.

## crosstalk

See *acoustic interference* on 2-11.

## crystal

An electronic device made of quartz and having crystalline piezoelectric properties. In ultrasonic terminology, crystal refers to the piezo element, a ceramic made of lead, zirconium, and titanate which is used as part of the basic element of the transducer.

## current consumption

Flow of charge required from the power supply by the unit in order to operate properly.

## current loop or signal current loop (4-20 mA)

A type of analog sensor output that impresses a current across the connected load. The impressed current ranges from 4-20 mA. This type of output is less susceptible to electrical noise.

## current pulse

A burst of electrical energy. A rapid increase in the flow of charge followed by a return to the original rate of flow.

## current sinking output

See *NPN current sinking output* on 2-17.

## current sourcing output

See *PNP current sourcing output* on 2-17.

## cycle time

See *response time* on 2-18.

## Dairy 3A Sanitary Standards

A set of voluntary standards formulated by joint government, supplier, and consumer effort to ensure that all dairy equipment can be thoroughly cleaned to prevent unsanitary conditions. Sensor housings, made of NORYL® plastic meet these standards for Hyde Park sensors and are available in gray to distinguish them from the standard blue ULTEM® housing.

## deadband

The minimum allowable distance out from the sensor for reliable object detection. It is determined by a time period beginning when the transducer is energized, producing a sound wave, and

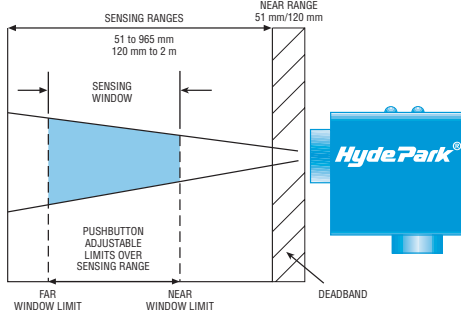

when the resulting oscillations from that sound wave diminish to the point where it is possible for the transducer to accurately receive its echo. This space or “blind zone” in front of the sensor is not reliable for object detection. For Hyde Park ultrasonic sensors, the deadband can extend from 14 mm (0.75") to 203 mm (8") from the sensor, depending on the model selected.

## delay on/off control

The output of a sensor may be delayed until a fixed time after the event occurred which triggered the output. Generally, the state of the sensor must stay constant or the timer will restart. Delay on refers to the time interval between when the sensor detects the object and when the output changes state. Delay off refers to the time interval between when the sensing ceases and when the output changes state.

## DELAYS push-button

A push-button on the SUPERPROX® Model SM503 series sensors used to set on and off delay times.

## DeviceNet Capability

Hyde Park's SM600FP flat-profile and SM900 sensors are available with a

DeviceNet interface. DeviceNet is a 4-wire, self-powered, multiplexed serial communications bus. In a typical application, the Hyde Park sensor is plugged into the bus, usually with other sensors and actuators, which all draw their operating power from the bus. A master device, usually a PLC, coordinates communication activities on the bus: polling sensors and controlling actuators. The benefits of this type of interconnect scheme include: alphanumeric-based information exchange between Hyde Park sensors and the DeviceNet network, universal sensor hardware for a multitude of applications, and improved error/fault reporting capability.

## differential height inspection

A sensing application in which an array of Hyde Park SUPERPROX® Model SM504 series sensors are programmed to simultaneously detect various specific heights and produce an output when a specific height is not detected.

## digital output

A discrete output that is always in one of two stable states.

## diode

A two-layer semiconductor that allows current to flow in only one direction - from anode to cathode.

## dip switch

One or more switches housed in a “dual in-line package” and soldered into a circuit board, thus providing a small and economical switch. In Hyde Park ultrasonic sensors, the tiny switches in the control compartment of the SUPERPROX® Model SM5XX series sensors used to configure the sensor for a given application. See Product Information section.

## direct current (DC)

Electrical current whose electrons flow in one direction only. It may be constant or pulsating as long as its movement is in the same direction.

## direct/inverse output

Refers to the polarity of the analog output. “Direct” output means that the voltage or current decreases as an object moves away from the sensor. “Inverse” output means that the voltage or current increases as an object moves away from the sensor.

## dual-level on/off latch

A logic function in which an input signal to the latch module causes the

module's output to turn on. The output remains on until a signal is applied to a second input to reset the latch. The “latch” function is usually implemented in a hardware module or PLC software. The on-board microprocessor in the

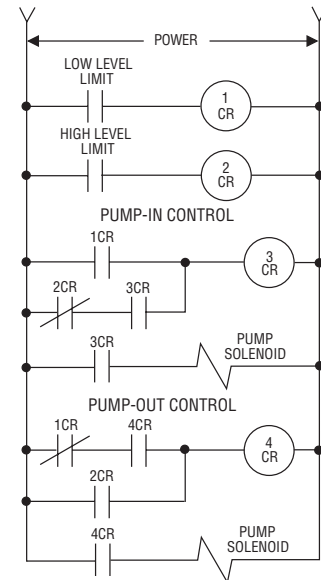

SUPERPROX® Model SM502/602/902 series dual-level control sensor models performs a stand-alone on/off logic latch control with respect to a preset high and low limit switch point. This eliminates the need for any external control relay or programmable controller program logic to perform either a pump-in or a pump-out level control application. In the pump-in mode, the sensor output latches on when the level drops to the low level limit and latches off when the level rises to the high level limit. In the pump-out mode, the sensor output latches on when the level rises to the high level limit and latches off when the level drops to the low level limit. The preceding diagram illustrates the on/off relay latch control logic emulated by a SUPERPROX® dual-level control sensor.

## dual-level sensing

One of several sensing techniques within the capabilities of Hyde Park ultrasonic sensors, where the user sets two limits, a high level and a low level, within which the level of a product is to be controlled through a discrete on/off output. See information on the Model SM502/602/902 series sensors for a full explanation of the three versions available.

## echo

The ultrasonic energy which reflects off an object and returns to the detector.

## electrostatic

Refers to motionless electrical charges. Charges exert mechanical forces on



each other which can be used to generate ultrasonic waves.

### **environmental compatibility**

Hyde Park sensors are capable of operating in a variety of environments and conditions, including selected acids, bases, salts, hydrocarbons, oils, solvents, food products, and others.

### **ESD (electrostatic discharge)**

The sudden discharge of electrical charge. The charge is commonly built up as a result of sliding friction between dissimilar materials (shoes and carpet). The potentials may reach 50 kilovolts (kv) in dry environments. This phenomenon may cause destruction of electrical equipment if not protected.

### **ETL safety label**

The label which guarantees that advertised Hyde Park AC-powered sensors have been approved by a nationally recognized laboratory and comply with federal law.

### **false echo**

See *Coincidental Secondary Echo Condition* on 2-13.

### **far (low) limit**

The boundary of the sensing "window" farthest from the Hyde Park sensor.

### **fixed sensing window (width)**

A defined space in front of the sensor within which object detection takes place. The Hyde Park Model SM600 family of proximity sensors have fixed sensing window widths.

### **fluorosilicone rubber**

Fluorosilicone rubber is an elastomer that is resistant to all food products and chemicals, including many solvents and petroleum-based products found in industry. Many of Hyde Park's sensors use this material as an ultrasonic coupling material (see *coupler* on 2-13).

### **foreground suppression**

An ultrasonic sensor's capability to disregard any or all pulse-echo returns from objects located between the sensor and where the near sensing window limit is set.

### **frequency**

The number of times a periodic action occurs in a unit of time. The number of

hertz (Hz, the unit of frequency, one cycle per second) that an electric current completes in one second.

### **frequency drift**

A percent of deviation from a specific number of cycles per second (Hz) for a given sonic or ultrasonic waveform.

### **gain adjustment**

Determines the degree of sensitivity for a sensor.

### **gain setting**

Several SUPERPROX® sensor models are capable of operating at high or low gain. Higher gain can overcome signal loss due to poor reflective surfaces, high environmental temperature, etc. Choose low gain if stray echo or secondary echo problems occur.

### **gap detection**

Sensing for either voids or spaces between containers on a conveyor line system. Upon sensing a gap, the sensor can be used to automatically start, stop, or modulate speed of associated in-line conveyors and machinery.

### **gate-controlled sensing**

A unique feature of the SUPERPROX® Model SM504 series sensors in which they perform periodic sensing of multiple objects or locations. Depending on the application, one or more of these sensors are triggered with a switching device to prevent possible false sensor outputs due to changing foreground object conditions.

### **ground**

Referring to earth ground, used as a return for electric currents and as an arbitrary zero of potential. It is important at high power levels mainly for safety reasons. Also refers to the electronic chassis or enclosure ground or to DC common (voltage reference to the negative side of a DC power supply).

### **hermetic seal**

An air-tight seal. All Hyde Park sensors are hermetically sealed to withstand harsh environments.

### **hertz (Hz)**

The international unit of frequency, equal to one cycle per second. Hyde Park sensors operate at a frequency of 75 kHz, 200 kHz, and 500 kHz.

### **hysteresis**

Means "to lag behind". An electronic design consideration for ultrasonic sensors such that the point at which the

sonic echo is received by the sensor is different than the release point of the output. This differential prevents the output of a sensor from oscillating near switching points. It is also a function of the number of echoes that must come from either inside or outside the window to switch the sensor's output.

### **impedance**

Measured in Ohms, total opposition a circuit, cable, or component offers to alternating current (AC) at a given frequency. Impedance includes resistance, inductive reactance, and capacitive reactance.

### **input**

The signal (voltage or current) applied to a circuit to cause the output of that circuit to change state. Also, the terminals, jack, or receptacle provided for reception of the input signal.

### **input voltage**

The power source required by an electric or electronic device (e.g., a self-contained sensor) in order for the device to operate properly.

### **intrinsic safety**

A design technique applied to electrical equipment (e.g., sensors and switches) and wiring for hazardous locations. The technique involves limiting electrical and thermal energy to a level below that required to ignite a specific hazardous atmosphere. Intrinsic safety design often eliminates the requirement for expensive and awkward explosion-proof enclosures.

### **IP rating**

A rating system which defines the suitability of sensor and sensor system enclosures for various environments. Similar to NEMA ratings for enclosures. Hyde Park ultrasonic sensors are rated IP66 and IP67 and carry the following protection levels:

IP66 - dust tight, strong jets of water (hose down)

IP67 - dust tight, submersion in water for up to 30 minutes at 1m

### **isolated output (or input)**

A type of input or output that floats electrically from its host circuit. This type of circuit may be used to break ground loops.

### **jam detection**

Sensing for a backup of containers on a conveyor line system due to either

down-stream container jams or machinery stop conditions. Upon sensing a jam, the sensor can be used to automatically alert an operator or stop associated up-stream conveyors and machinery until the jam is clear.

### **kHz**

Kilohertz, 1000 Hertz

### **latch (latching logic)**

See *dual-level on/off latch* on 2-14.

### **LED (light emitting diode)**

A semiconductor device that emits incoherent light formed by the P-N junction. Light intensity is roughly proportional to electrical current flow. LEDs are used in Hyde Park sensors to indicate power on, object in view, output status, etc.

### **limit adjustment resolution**

The smallest allowed distance that a limit can be changed.

### **LIMITS push-button**

A push-button in the SUPERPROX® family of sensors used to set the position of limits, within which the detection of objects and levels takes place.

### **linearity**

The deviation from a best-fit straight line representing the slope of an analog output. Using the Model SM506 with 4 to 20 mA output as an example, the linearity is  $\pm 0.10\%$  of the span. If the span is 20", the linearity is a  $\pm 0.02"$  deviation above or below the best-fit straight line representing the slope of the output.

### **linear output**

Characteristic of analog ultrasonic sensors (e.g., Hyde Park SUPERPROX® Model SM506 series), the output has a "straight-line" relationship to the sensing distance between the near and far sensing limits.

### **line transients**

Voltage or current fluctuations on power conductors or input/output conductors. The transients are usually caused by noisy electrical equipment such as frequency-modulated motor drives or electro-mechanical relays. The noise may be conducted into the wires or induced magnetically or capacitively.

### **load**

A device through which current flows and has a voltage drop across it.

### **load resistance**

Resistance is the ratio of voltage to current flow,  $V/I$ , measured in Ohms ( $\Omega$ ). Load resistance is that resistance seen by current from an output. Most sensors have a limit on how small resistance can be, since small resistance leads to excessive current flow and possible damage. Sensors with a 4-20 mA output have a limit on how large the load resistance can be since the sensor may not have enough voltage to impress a current.

### **logic/actuation**

The capability of the sensor to make decisions and control actuation. Hyde Park's Model SM500/600/900 families of "smart" sensors have this capability.

### **loss of echo**

For Hyde Park sensors, it occurs when the sensor does not receive echoes from an object within its sensing range for more than one second. When this occurs, the sensor's output automatically switches off. When the sensor again receives echoes from the object it will either switch or remain in the same state depending on where the echoes are received relative to the control limits. Some other sensors allow one or several cycles to pass before indicating loss of echo and going to a predetermined output state.

### **mA**

Abbreviation for milliAmpere. 1/1000 of an Ampere.

### **microprocessor-based intelligence**

One of the more noteworthy advances in ultrasonic technology which has given ultrasonics such features as error compensation and computer interface capability, opening the door to new control applications. For Hyde Park ultrasonic "smart" sensors, it is the capability to "learn" their surroundings, ignore non-target objects in the sensing range, make decisions, and control actuation consistently, operation after operation.

### **MICROSONIC®**

The registered trademark of the Hyde Park line of ultrasonic thru-beam sensors.

### **motion detection**

Sensing for a slowdown or stopping of back-to-back containers on a conveyor line system due to either down-stream machinery slowdown or stop conditions. Upon sensing a slowdown or stop in motion, the sensor can be used to

automatically alert an operator or stop associated up-stream conveyors and machinery until the back-to-back containers begin moving again.

### **multiplexing**

A design in which an electronic control circuit interrogates each sensor of an array in sequence. Different functions sharing the same hardware, usually each function having exclusive use for a limited, but recurring time.

### **near (high) limit**

The boundary of the sensing "window" nearest to the sensor.

### **NEMA (National Electrical Manufacturers Association) Enclosure Standards**

A set of guidelines established by NEMA to determine levels of physical protection an enclosure, like a sensor housing, needs for various environments. Such a surrounding case is constructed to provide a degree of protection to personnel against incidental contact with the enclosed equipment against specified environmental conditions.

A brief description of the NEMA enclosure standard types used in the manufacture of Hyde Park ultrasonic sensors follows:

**NEMA 1** intended for indoor use primarily to provide a degree of protection against contact with the enclosed equipment.

**NEMA 3** intended for outdoor use primarily to provide a degree of protection against windblown dust, rain, sleet, and external ice formation.

**NEMA 4** intended for indoor or outdoor use primarily to provide a degree of protection against windblown dust and rain, splashing water, and hose-directed water.

**NEMA 4X** intended for indoor or outdoor use primarily to provide a degree of protection against corrosion, windblown dust and rain, splashing water, and hose-directed water.

### **normally closed (N.C.)**

For a relay output, this implies the two contacts are connected, with connection broken only when the "sensing event" occurs. Other outputs are similar: NPN output at ground floats when event occurs. PNP output at voltage floats when event occurs.

### **normally open (N.O.)**

Similar to normally closed (N.C.) except "not" connected.

## NORYL®

Optional to the user, the plastic material used in the housing (case) of Hyde Park sensors which has been approved for USDA-Dairy 3A Sanitary Standards. Hyde Park sensor housings made of NORYL® are gray to distinguish them from the blue ULTEM® housings.

## NPN

A type of transistor which requires a positive power supply, NPN refers to the structure of a transistor, i.e., excess hole (P) “sandwiched” between two excess electron (N) materials. This transistor has the characteristic that current injected into the base (P) allows current flow from collector to emitter as long as the base voltage is about 1/2 V higher than the emitter. In practice, NPN outputs are used to connect loads to ground.

### NPN current sinking output

The output of a DC device that switches ground (DC common) to a load. The load is connected between the output of the device and the positive side of the power supply. The switching component is usually an open collector NPN transistor, with its emitter tied to the negative side of the supply voltage.

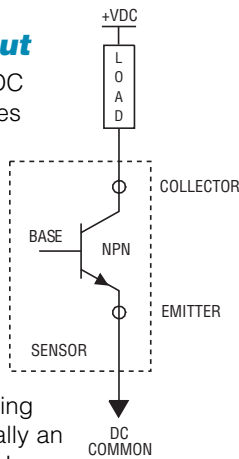

### object (target)

The material, liquid, solid, transparent, moving or static that is being detected by the sensor in a given application.

### object sensing mode

One of two operational modes (the other is background) in which the SUPERPROX® Model SM500, SM503, and SM504 sensors operate as a universal, all-materials-type, proximity sensor. Sensing in this mode is done by first setting the window limits as shown in the illustration and ensuring that the object surface is properly positioned in-line and parallel with the sensor face. In this mode, the sensor accepts all ultrasonic pulse echoes received off objects that are either at or within the window limits shown in blue. All other echoes, excluding coincidental secondary echoes, received off objects outside the window limits are ignored.

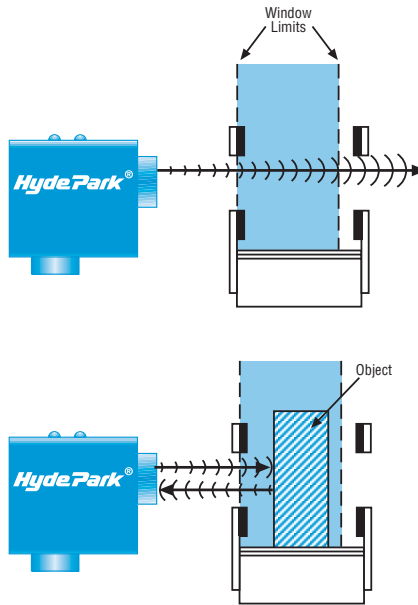

### object surface area versus distance to sensor

See *Sensing Considerations* section on 2-23.

### off-delay time

Refers to the time delay between when the sensor stops sensing an object and when the output state switches inactive. The Hyde Park SUPERPROX Model SM503 series sensors provide both on- and off-delays.

### off-state leakage current

The current that flows even when an output is off. For most transistors, this is in the  $\mu\text{A}$  range and is negligible. But solid state AC relays can allow  $\mu\text{A}$  to flow which sometimes causes problems with PLC inputs.

### on-delay time

Refers to the time delay between when the sensor starts sensing an object and when the output state switches active. The Hyde Park SUPERPROX Model SM503 series sensors provide both on and off time delays.

### open collector

Open collector NPN describes a transistor output that sinks load current to common when the output is “on” (energized). When the output is “off”, no current flows. A pull-up resistor or other type of load is usually provided by the user.

Open collector PNP describes a transistor output that sources current from the sensor supply when the output is “on”. A pull-down resistor or other type of load is usually provided by the user.

## oscillate

Change state in a regular, periodic fashion like, for example, a sine wave.

## output

The useful power or signal delivered by a circuit or device.

## output load range

The set of all values of impedance or resistance which can be connected to an output.

## piezo

Literally, related to pressure. Used to refer to a material which exhibits the piezoelectric effect.

## piezoelectric

The phenomenon of expansion along one axis when subjected to an electric field or production of an electric field when mechanically strained along an axis. Used to generate and sense ultrasound.

## PNP

A type of transistor which sources current, PNP refers to the structure of a transistor, that is a thin layer of excess electron (N) semiconductor “sandwiched” between two layers of excess hole (P) semiconductor. This transistor has the characteristic that current injected into the base (N) allows current flow between the emitter and the collector (the two P layers) as long as the base is about a 1/2 V lower than the emitter. In a sensor with a PNP output, this emitter is usually internally connected to the sensor power pin. In practice, PNP outputs are used to provide power to loads which are connected to ground. See the diagram under “PNP current sourcing output” on page 2-18.

### PNP current sourcing output

The output of a DC device that switches positive DC to a load. The load is connected between the output of the device and the ground (DC common) side of the power supply. The switching component is usually an open collector PNP transistor, with its emitter tied to the positive side of the supply voltage.

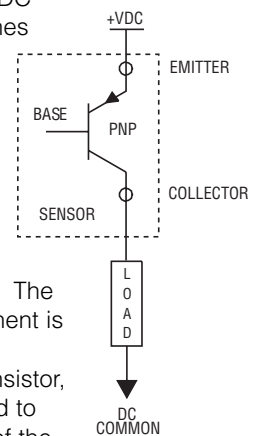

## potentiometer

A variable resistor, directly controlled by a dial, knob, or lever, used most commonly to produce a voltage proportional to a variable of interest, e.g., time delay, rate, etc. On the Hyde Park SUPERPROX® Model SM505 series motion sensor, the rate potentiometer sets the minimum threshold rate at which the sensor output switches either off or on, depending whether there is a decrease or an increase in the container motion rate. The delay on potentiometer on the same model series sets the minimum delay time before the output switches from off to on after container movement resumes at or above the setting of the rate potentiometer.

## potting

Sealing by filling with a substance to exclude moisture. Hyde Park sensors are potted with an epoxy.

## power/connection type

The second numerical digit in the Hyde Park sensor model number which indicates the AC or DC voltage range and the type of connection, connector, or cable style.

## power consumption

The product of current and voltage, normally measured in watts. The power used by a device such as a Hyde Park sensor.

## power supply

A device that provides the source of power (current and voltage). Regulated supplies are recommended for use with Hyde Park products.

## proximity sensing

The technique used to determine whether an object has come close enough to a sensor to trigger an output. For Hyde Park sensors, it is the detection of object presence when the object is in front of the sensor and within the sensing range and sensing “window” of the sensor.

## pull-up resistor

Load resistor connected between NPN open-collector (sinking) output and load voltage (usually supply voltage). This creates an output voltage. Lower values will help reduce electrical noise pick-up on the output cable.

## pull-down resistor

Load resistor connected between PNP open-collector (sourcing) output and

common. This creates an output voltage. Lower values will help reduce electrical noise pick-up on the output cable.

## pulse

A current or voltage which changes abruptly from one value to another and back to the original value in a finite length of time. Used to describe one particular variation in a series of wave motions.

## push-button configuration

The arrangement of push-buttons that are used to setup a Hyde Park ultrasonic sensor for a specific sensing application.

## PVC

Polyvinyl Chloride, a popular plastic used extensively in sanitary plumbing, automotive, and household applications. Hyde Park’s sensor cable is jacketed with PVC and meets FDA requirements for intermittent contact with food.

## rate potentiometer

A potentiometer whose position is proportional to a speed, e.g., a sensor on a can line might trigger when the speed exceeds a certain value set by the rate potentiometer.

## reflector angle

The angle between the reflective surface of a target and the beam-axis of the sensor. The optimum angle for sensor performance is 90°.

## remote type sensor

A sensor where the small piezo elements are far from the sensor. Hyde Park sensors with the remote sensing heads are typically used in extremely tight areas where it is impossible to mount and use a regular style sensor.

## repeatability

Describes the error in reporting the position of an object (or the position of a window edge) as the object is removed to another location then replaced in exactly the same location.

## resistance

In DC circuits, the opposition a material offers to current flow, measured in ohms ( $\Omega$ ). In AC circuits, it is the real component of impedance, and may be higher than the value measured at DC. (Note that “real” is used in the mathematical sense of “not imaginary.”)

## resolution

The smallest change capable by an

analog output. Resolution may appear in a specification in several ways: as inches of a set span or, depending upon the type of output, in volts or current of an analog output level. This specification does not indicate accuracy.

## response potentiometer

A potentiometer whose setting is proportional to the delay and filtering applied to an output.

## response time

**(also called sensing rate or cycle time)**

In ultrasonic sensing, the elapsed time between the transmission of a pulse and the pulse echo reception. The response times for Hyde Park ultrasonic sensors vary from 0.5 milliseconds for the Model SM600 series to 200 milliseconds for the Model SM500 series. The faster the response time, the greater the sensor’s capability of detecting a quickly changing object position and the shorter the sensing range. The Model SM606 analog sensor, with a response time of 0.5 ms, samples at the rate of 2,000 times every second within a fixed window of 1.5 to 2 inches from the sensor.

## retroreflective

Energy which impinges on an object is reflected back toward the source.

## reverse polarity

Interchanging the connections, usually power connections, so that what was connected to the higher voltage is now connected to the lower voltage.

## RS232

An ANSI standard for serial communication which defines voltages, signals, and connections. This is the most common “standard.” It is used on most personal computers and is simple to implement. A Hyde Park sensor with the RS232 feature means that the sensor can communicate with a terminal or simple lap top computer.

## sensing limits

The boundaries, near and far, high level and low level, that define the sensing window. See “sensing window”.

## sensing mode

The arrangement of the Hyde Park SUPERPROX® Model SM500, SM503, and SM504 sensors, through a simple dip switch, to function or operate in a particular manner. See *object sensing mode* on 2-17 and *background sensing*

mode on 2-12.

## sensing range

The total possible sensing capability of the sensor, beginning after the dead-band, and extending out as far as the sensor is able to reach effectively. Hyde Park SUPERPROX® sensors have sensing ranges up to 79 inches. Hyde Park MICROSONIC® thru-beam sensors have sensing ranges from zero to 72 inches.

## sensing window

For Hyde Park's SUPERPROX® sensors, it is the volume of space in front of the sensor within which the object detection takes place. This space is defined two-dimensionally by two limits, near and far, high and low. Suitable objects that are present at or within these limits, and reflect sound energy back to the receiver, will cause the sensor's output to change (shortest and longest elapsed time for valid echo returns). The window is adjustable in the Model SM500 family sensors and fixed in the Model SM600 family sensors.

## sensor angle (with respect to a smooth, flat surface)

The angle created by the beam axis and its perpendicular, the latter represented by a smooth flat surface of an object. Hyde Park specifications call for this angle to be  $90^\circ \pm 10^\circ$ . If the flat-

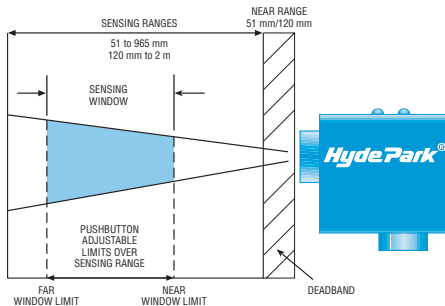

object surface is severely tilted away from the perpendicular of the beam axis, the echo is deflected away from the sensor, preventing the object from being detected.

## sensor functionality

Refers to what the user wants the sensor to do. The five recognized functions are: presence/absence, positioning, inspection, condition measurement, or identification.

## serial communications

A method of passing information sequentially, one bit at a time.

## shape of the object

See *Sensing Considerations* section on 2-23.

## shield

A conductive envelope around the primary conductors that provide an electronic barrier to electromagnetic interference. All Hyde Park sensors are shielded to limit the amount of RF energy emitted by the sensor, a requirement for CE approval. They are also shielded to prevent unwanted external noise from affecting sensor operation.

## shielded cable

A cable that is protected against electrical and magnetic noise pickup. Cable may be shielded by a variety of methods and materials. Aluminum foil is most common but is less effective at lower frequencies than the braid-type of shield.

## silicone rubber

Silicone rubber is an elastomer that is resistant to all food products and many chemicals found in industry. Many of Hyde Park's sensors use it as an ultrasonic coupling material (see "coupler" on 2-13). It is pliable yet damage-resistant nature makes it ideal for coupling ultrasonic energy to the air.

## single file conveyor sensing mode

The setup configuration of a Hyde Park SUPERPROX® Model SM505 motion sensor to detect the movement of containers on single file conveyors.

## sinking

Current flows into the connection. NPN transistors are usually current sinking outputs.

## "smart" sensor

The capability of a sensor to use the information or data it has detected and, through its microprocessor, to actuate a specific outcome in a specific application setting. For example, Hyde Park's "smart" SUPERPROX® sensors use a discriminating microprocessor and push-button setup program to detect only the designated object within the sensing window while ignoring other foreground, lateral, and background objects. Another example is the Hyde Park dual-level sensor that detects the level at which a pump is to be turned on or off and outputs a signal causing the pump to turn either on or off. The same sensor can be configured to sound an alarm at a specific level.

## sonic frequency

Frequency of the acoustic wave expressed in thousands of cycles-per-second (kHz). Generally, higher frequencies will have higher attenuation rates in air. Hyde Park Model SM500 proximity sensors have a frequency of 200 kHz; Model SM100/700 thru-beam sensors have a frequency of 180 kHz; Model SM600 miniature proximity and Model SM800 miniature thru-beam sensors have a frequency of 500 kHz.

## sourcing

Current flows out of the connection. PNP transistors are usually current sourcing outputs.

## span

The distance between the set sensing limits (near and far) of a sensor with an analog output (e.g., Hyde Park Model SM506 series and Model SM606 series).

## step response

Refers to the time it takes a sensor output to respond to an instantaneous change in object position.

## SUPERPROX®

The registered trademark of the Hyde Park line of ultrasonic proximity sensors.

## surface-to-beam angle

See *Sensing Considerations* section on 2-23.

## surface reflection properties

See *Sensing Considerations* section on 2-23.

## switching rate

The frequency of a binary signal.

## synchronized sensing

Coordinating the sampling time of one sensor to other events. Frequently used with multiple sensors to eliminate interference occurring according to a common schedule. An example of synchronized sensing is the use of an array of SUPERPROX® Model SM504 series sensors to detect a full-case condition.

## temperature

See *Sensing Considerations* section on 2-23.

## temperature dependence

A specification that indicates the amount of apparent position drift with respect to temperature drift. For example, if the span is set to 20" and the temperature drifts 8°C, then the sensor's

output will drift and the apparent object position will shift by 0.0096" (0.006% of span/ °C or 0.00006 x 20" x 8). The SUPERPROX® Model SM50X and SM60X analog sensor series have temperature sensors embedded in their housings which compensates for changes in ambient temperature.

### thru-beam (or break-beam) sensing

A sensing technique in which the object to be detected passes between an aligned transmitter and receiver. The Hyde Park MICROSONIC® sensors, used in this technique, are defined as continuous-wave devices in which the

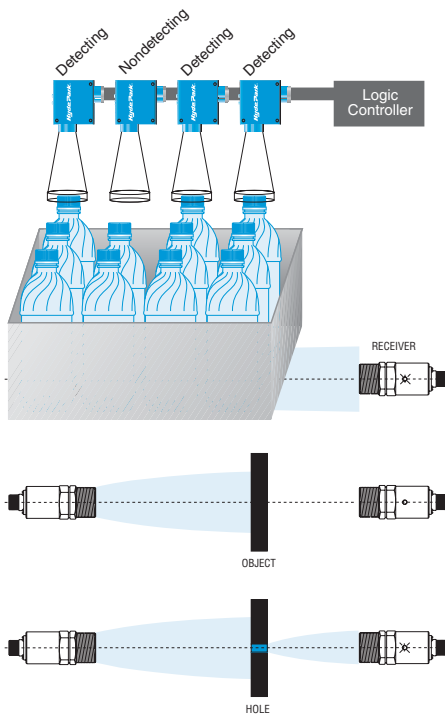

transmitter emits a continuous ultrasonic beam which is picked up by the receiver. When an object passes between the transmitter and receiver and breaks the beam, object presence is detected and the output of the receiver switches. Or, when a hole allows the beam to pass through to the receiver, the output of the receiver switches.

### transducer

A device used to convert one form of energy into another form of energy. The transducer in the Hyde Park SUPERPROX® sensors converts electrical energy into transmitted sound energy and then, through its receiver, converts the reflected sound energy (echo) into electrical energy. The MICROSONIC® sensor transmitters convert electrical energy into sound

energy and the receivers convert sound energy into electrical energy.

### TRIAC

A solid state device used to switch AC currents. The SM52X and SM57X have an AC switch output.

### turbulence

Motion of air which rapidly fluctuates in direction and velocity. With reference to sensing, the unstable condition of the air in and around the sensing application. This condition can cause dispersion and deflection of the transmitted sound energy. The maximum sensing range is reduced by the weakened or diverted energy due to this condition and thus should be tested prior to operation.

### ULTEM®

A trademark for a high temperature, high strength plastic (polyetherimide) manufactured by The General Electric Company and used in the housings of Hyde Park ultrasonic sensors.

### ultrasonic operating principle

Ultrasonic sensors have an acoustic transducer which is vibrating at ultrasonic frequencies. The pulses are emitted in a cone-shaped beam and aimed at a target object. Pulses reflected by the target to the sensor are detected as echoes. The device measures the time delay between each emitted and echo pulse to accurately determine the sensor-to-target distance. The Hyde Park SUPERPROX® sensor determines this distance by measuring the elapsed time between the transmission of a pulse and the pulse echo reception. The transmitted pulse begins a time clock; the first returned pulse echo stops the clock. Given the elapsed time, the sensor software calculates the distance traveled by the pulse from the sensor to the object, using the formula,  $D = TV_s/2$ , where D = distance from the sensor to the object; T = elapsed time between transmission and reception of an energy pulse; and  $V_s$  = velocity of sound ... approximately 1100 feet per second. During operation, the calculated distance (D) between the sensor and the object is compared to the distance associated with the sensing window limits (see definition on 2-19). If D is at or within these limits, an output is generated. The output remains on until the echo either does not return or it returns from outside the window limits at which time it switches off.

### ultrasonic sound

Pressure waves with a frequency that is above the range of human hearing...or above approximately 20,000 cycles per second (20 kHz). Ultrasonic technology uses electrical energy and a ceramic crystal (transducer) tuned to a specific frequency, to produce and detect mechanical energy in the form of waves of energy. Hyde Park ultrasonic sensors use a piezoelectric type crystal that is tuned to a specific frequency:

**75 kHz** for the SUPERPROX® Model SM900 - 8 series

**180 kHz** for the MICROSONIC® Model SM100/700 series

**200 kHz** for the SUPERPROX® Model SM500/900 series and the MICROSONIC® Model SM800 thru-beam series

**500 kHz** for the SUPERPROX® Model SM300 and SM600 proximity series and MICROSONIC® Model SM800 thru-beam series

### VAC

Voltage, alternating current

### volt (v)

A unit of electrical pressure. One volt is the electrical pressure that will cause one Ampere of current to flow through one Ohm of resistance.

### voltage

Electrical potential or electromotive force expressed in volts.

### warranty

An assurance by the seller of property that the goods or property are as represented or will be as promised. See Hyde Park's Warranty information in the Warranty section of this catalog.

### watt

A unit of electrical power. One watt is equivalent to the power represented by one Ampere of current with a pressure of one volt in a DC circuit.

### web break detection and material sag control

In this application, the manufacturer must constantly monitor and control material sag, as well as check for breaks in a web. In the automatic production process illustrated here, a machine draws material from the roll, processes it, then transfers it to the next stage. In the event of a process slowdown or machine jam, the material between the rollers will sag. The SM506 sensor, with an analog output, will detect the change in sheet-to-sensor distance. The output

of the sensor instructs the variable speed drive controlling the feed roll to slow down. The SM500 proximity sensor monitors material as it exits the process, and detects breakage. When a break occurs, the process must stop and the roller be re-fed. By locating the sensor at the outlet side, a break can be stopped before the rollers downstream run themselves empty and have to be re-fed.

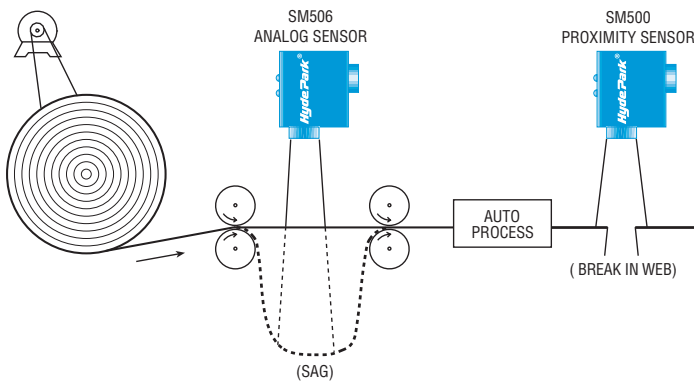

### **window**

See *sensing window* on 2-19.

### **window-edge accuracy**

Dimensional point of repeatability to detect an object at either near or far sensing window limit set points.

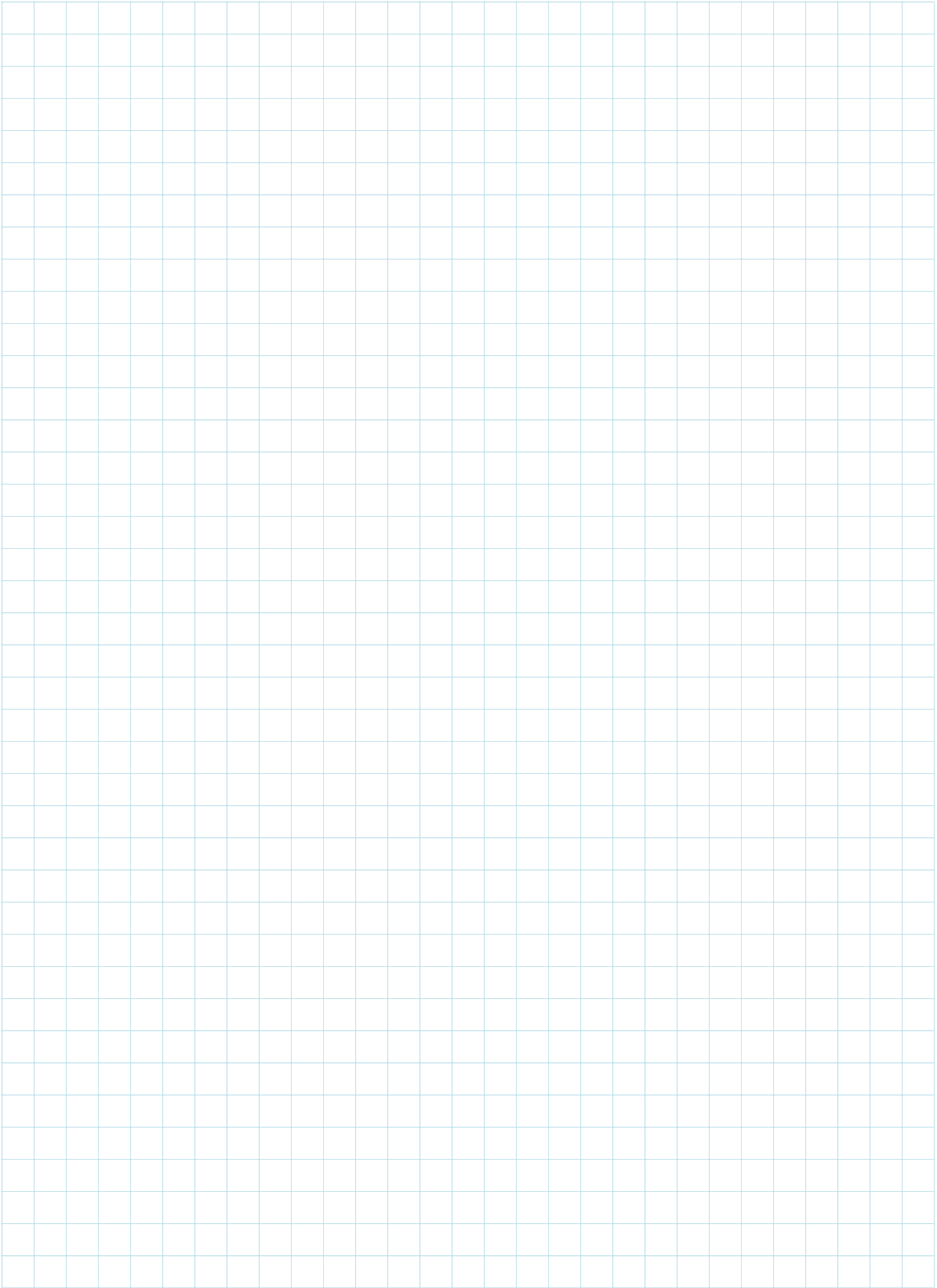



When considering a SUPERPROX® sensor for a particular application, certain ultrasonic sensing fundamentals should be understood to ensure top performance.

## Shape of the Object

Almost all object shapes can be sensed, provided enough reflected ultrasonic energy reaches the sensor. Smooth, flat objects, positioned perpendicular to the beam axis, are easier to detect than round objects. A cylindrical object can be detected at a greater distance than a spherical object with the same diameter. It is best to determine the sensing suitability of a given object under actual conditions.

## Object Surface Area versus Distance to Sensor

The amount of ultrasonic energy reflected back to the sensor from the object depends largely on the object surface area and its distance from the sensor. If an object is positioned, for example, 200 mm (8") from the sensor, the received echo is approximately 4 times stronger than if the object is at 400 mm (16"). Thus, it is possible that the echo strength from an object with a small surface area, placed at the maximum sensing distance, may be too weak to detect.

## Surface Reflection Properties

Almost all materials reflect ultrasonic energy and can be detected. Ultrasonic energy, striking a flat, hard, smooth surface, perpendicular to the transmitted sonic beam, is the ideal condition for reliable detection.

Conversely, materials with coarse, textured surfaces diffuse or absorb much of the transmitted energy. For example, granular products, foam rubber materials, and certain textiles and papers may need a stronger transmitted signal for reliable detection. Detection of foam

surfaces from soaps and similar products is also difficult and should be tested prior to installation.

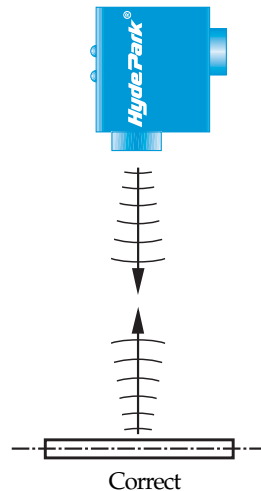

## Surface-to-Beam Angle

If a smooth, flat-object surface is severely tilted away from the perpendicular of the beam axis, the echo is deflected away from the sensor, preventing the object from being detected.

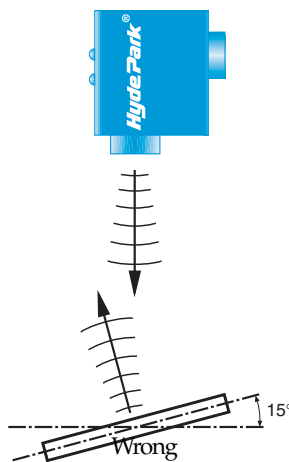

## Environmental Factors

The environment in which the sensing application takes place must also be considered.

## Ambient Acoustical Noise

Intense acoustical noise generated near the sensor may interfere with its operation. Offending noise sources are usually well above the range of hearing. Common sources of this type of noise may be: air nozzles, machine vibration, and sliding friction.

## Temperature

The velocity of sound in air is temperature dependent. The higher the temperature, the higher the velocity of sound. While the sensor is designed to compensate for gradual changes in temperature, acute ambient temperature changes can adversely affect the sensor's performance. This includes causing a sudden shift in the sensing window. If a hot object is to be detected, experiment by positioning the sensor so it is aimed at a cooler portion of the object. Also make sure the sensor is not sensing through hot air currents generated by the object as illustrated below.

## Air Pressure

Ultrasonic sensors are not intended for use in differential pressure environments. Normal atmospheric pressure changes have no significant effect on the performance of the sensors.

## Air Movement and Densities

Air currents, turbulence, and layers of different air densities can cause dispersion and deflection of the transmitted energy. The maximum sensing range is reduced by the weakened or diverted energy due to unstable air conditions.

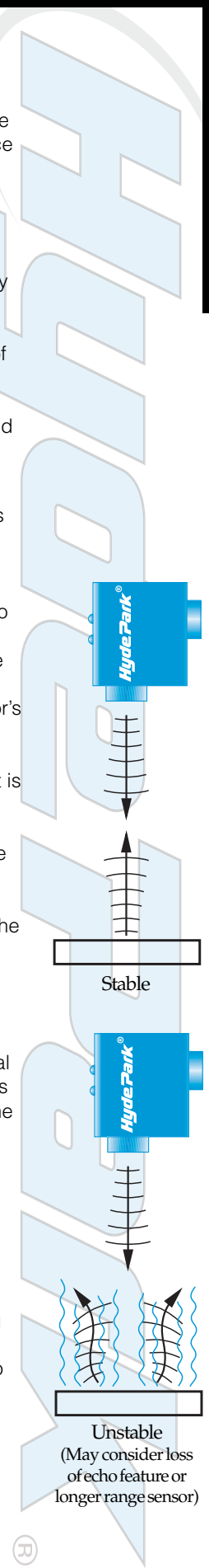

## Object Sensing Mode

The object mode enables the SUPERPROX® sensor to operate as a universal, all-materials-type, proximity detector.

Sensing in this mode is done by first setting the window limits as shown in Figure 1 and ensuring that the object surface is properly positioned in-line and parallel (See Figure 2) with the sensor face.

In this mode, the sensor accepts all ultrasonic pulse echoes received from objects that are either at or within the window limits as shown in Figures 2 and 3a. All echoes, excluding coincidental secondary echoes (explained below), received from objects outside the window limits (See Figure 3b) are ignored.

### Coincidental Secondary Echo Condition

When an object is properly positioned between the sensor and the window (See Figures 3b and 3c), the ultrasonic pulse from the sensor will reflect repeatedly between the sensor and the object, thus creating a series of secondary echoes.

A coincidental secondary echo condition exists when the distance traveled by the primary echo from an object at or within the window limits is a multiple of (most likely twice) the distance traveled by a secondary echo from the foreground object. As shown in Figure 3c, object #3 is properly positioned halfway between the sensor and the inner window limit and is mistakenly detected as if it were object #1. Exercise caution when considering a SUPERPROX® application to avoid this condition.

### Background Sensing Mode

This mode is recommended when detecting objects with round or irregular shapes and non-perpendicular profiles.

The background mode, using a unique secondary echo lockout function, enables the SUPERPROX® sensor, with a fixed background target, to operate as a universal, all-materials-type, break-beam detector.

After setting the window limits on the fixed target (See Figure 4), make sure the ultrasonic transmission path between the sensor and the target is clear of obstructions.

Once set, the sensor accepts only the first (primary) ultrasonic pulse echo received from the target within the window limits as shown in Figures 4 and 6a. In this mode, the echo is received and detected as an object not present. Object presence is detected when the object interrupts the sonic pulse transmission path between the sensor and the fixed target, as shown in Figures 5, 6b, and 6c.

As a result of the secondary lock-out function, the sensor is permitted to receive only the primary echo after each sonic pulse. All subsequent secondary echoes are "locked out".

If the first echo received from the object travels a lesser distance than the first echo from the fixed target, that object is detected as being present.

As shown, if the echo of an object is not received (Figure 6b, object #1), or if the first echo is received from an object that is outside the window limits (Figure 6c, object #2), the object is detected as being present.

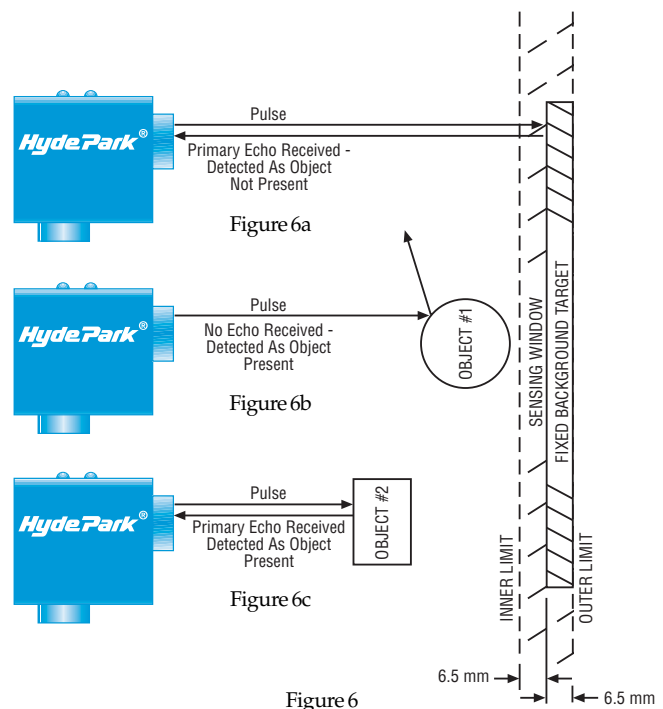
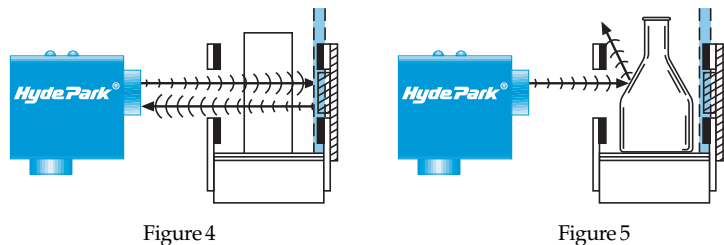
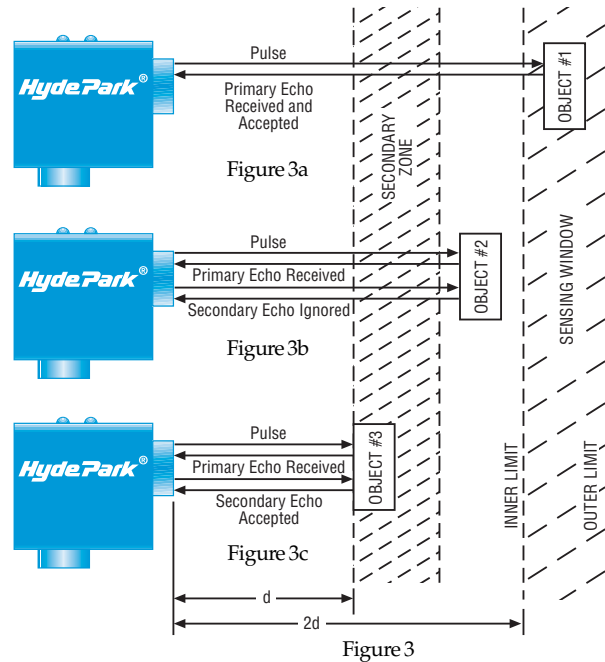
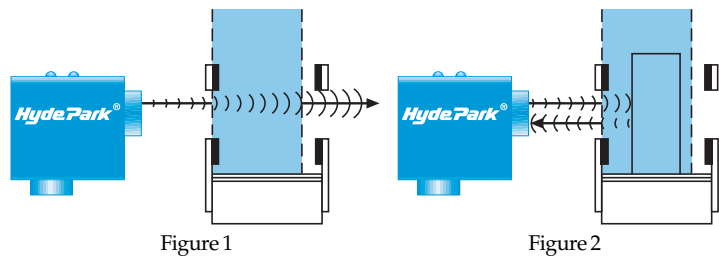

## Model VM Series

VIRTU™

### Ultrasonic Proximity Sensors



CE

**The next generation compact ultrasonic proximity sensor outperforming many other sensor types in both application and cost.**

The new Virtu™ ultrasonic sensor developed by Hyde Park features sensing ranges from 50.8 mm ( 2") up to 508 mm (20"). This versatile, powerful proximity sensor sells for under \$100, a price breakthrough for superior ultrasonic technology.

Virtu's dual-mount body style, with its M18 x 1 threaded snout 0.89" long and a 1.49" rectangular body for a total length of only 2.38", and tough VALOX® housing make it not only ideal for many OEM applications but also an unflinching performer for an array of packaging applications, including food and beverage. Available in cable or connector style, Virtu is the first sonic compact sensor to offer a dual mounting feature. It operates on 12 to 24 VDC and provides either a sinking (NPN) or a sourcing (PNP) output. Virtu also has teach-in window capability, and no downtime is required for sensor recalibration when colors, materials, or shapes change.

With protection ratings of NEMA 4X and IP67, this CE certified sensor is resistant to dust, 100% humidity, most acids and bases, and high pressure washdowns that often leave water buildup on

the sensing face. This sleek sensor is virtually impervious to the effects of splashing food, caustic cleaning solutions, and changing light conditions or colors. Shielding and filtering make the fully encapsulated sensor resistant to radiated or conducted energy.

#### Operation

The Virtu Model VM series is a self-contained, pulse-echo, proximity sensing device that both transmits and receives sonic energy within a 508 mm (20") maximum sensing range. Operating on 12 to 24 VDC, and employing the latest piezoelectric and microprocessor technology, Virtu sensors detect only those designated objects within a set "window" and ignore all surrounding sonic interference.

Prior to operation, a simple and easy "teach" function is used to set the sensing window limits through either a remote or inline cable push-button. A near and far limit for a desired sensing window can be set anywhere within the sensing range and may be set to either encompass the full sensing range or be as small as 6 mm (0.25").

The sensor is equipped with a two-color status LED to show the state of the output. When the output is active, the LED is amber, regardless of whether the output is normally open or closed. When the output is not active, the LED is green. The LED also serves to show the

- Sensing range of 50.8 mm (2") up to 508 mm (20")
- Dual-mount flat-profile body style and 18 mm barrel
- Sinking (NPN) or a sourcing (PNP) output available
- Rugged duty design for harsh environments
- Simple remote push-button accessory available for teaching of sensing limits
- NEMA 4X, IP67
- CE certified

VIRTU™ VM SERIES

sensing status of the sensor. With a normally open output and an object in the sensing window, the LED will be amber and switch to green when the object leaves the sensing window, switching off the output. With a normally closed output and an object in the sensing window, the LED will be green and switch to amber when the object leaves the sensing window, switching on the output.

### Setting the Window Limits

Before operating the sensor, you should teach the sensor the sensing window. The sensing window is the distance between the near and far limits. To teach the limits, press and hold the push-button. The LED fast flashes amber and then after holding the push-button for 3 seconds, the LED slowly flashes green indicating the sensor is in teach mode. Release the push-button, and the LED continues slowly flashing green indicating the sensor is waiting for the first limit. Place a target at either limit, and press and release the push-button. While the push-button is pressed with a target present, the LED turns amber indicating a valid echo is being detected. After teaching the sensor the first limit successfully, the LED slowly flashes amber indicating the sensor is waiting for the second limit. Place a target at the second limit, then press and release the push-button. While the push-button is pressed with a target present, the LED turns amber indicating a valid echo is being detected. After teaching the sensor the second limit, the two limits are saved in non-volatile memory. The LED fast flashes green for 3 seconds to indicate the limits were successfully saved. The limits can be set in either order.

To teach the default window of 25.4 mm (1.0" ), while the sensor is in teach mode requesting the first limit (LED slowly flashing green), place a target parallel to the sensor face at the center of the desired window. Press and release the push-button twice in succession within one second. The LED fast flashes green

indicating the limits were successfully saved. This sets the limits 12.7 mm (0.5 in.) in front of and behind the front surface of the target.

If not using an optional push-button, the process is similar. The white teach wire (pin 2) can be grounded to the blue DC return wire (pin 3) to simulate the pushing of the button. All LED indications and the teach sequence is identical to the previously detailed process.

While setting either limit, if no echo is detected, the LED fast flashes green and amber indicating no object is detected. After 5 seconds, the sensor resumes operation with the old limits. If either limit is not set in 30 seconds, a limit timeout occurs, the LED flashes green and amber for 3 seconds indicating the error. The sensor then resumes operating with the old limits.

### How Does It Work?

During teach and operation, the Virtu sensor continually and accurately measures the elapsed time from the first pulse echo received after each pulse transmission. The transmitted pulse begins a time clock to register the elapsed time of the first received pulse echo. Given the elapsed time, the sensor software calculates the distance traveled out to the object or surface and back to the sensor, using the formula  $D = TV_s/2$ , where: D = distance from the sensor to the object; T = elapsed time between the pulse transmission and its first received echo;  $V_s$  = the velocity of sound, approximately 335 meters (1100 feet) per second.

During operation, the calculated distance (D) between the

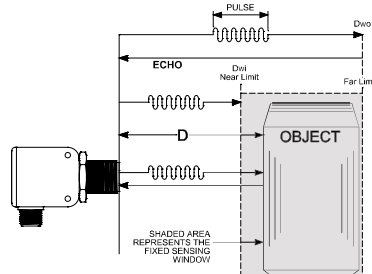

sensor and the object is compared to the distances associated with the window limits. These limits are shown in the illustration as Dwi and Dwo. If D is within these limits, an output is activated or deactivated, depending whether normally open or normally closed. The output remains in such state until the echo does not return or it returns from outside the window limits.

### Electrical Wiring

The sensor cable must be run in conduit, free of any AC power or control wires.

#### NPN Cable Style Wire

(dual-mount model only)

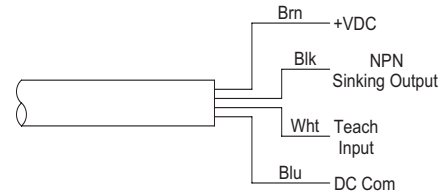

#### PNP Cable Style Wire

(dual-mount model only)

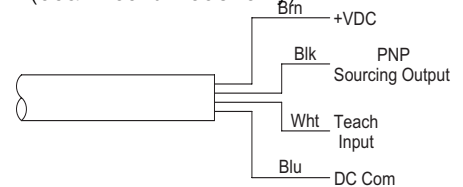

#### NPN Micro Connector Style

(dual-mount model only)

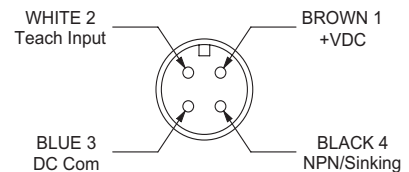

#### PNP Micro Connector Style

(dual-mount model only)

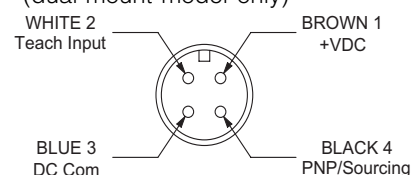

## Output Style

### NPN Output

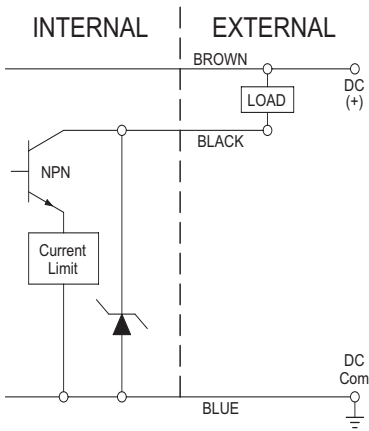

### PNP Output

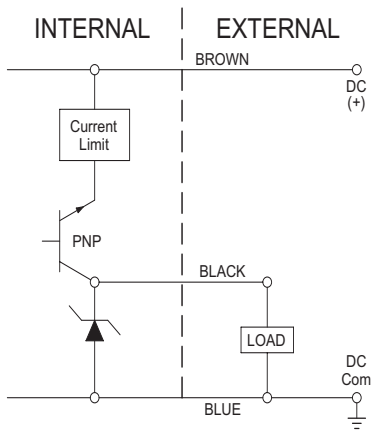

## Output Type

### NPN - Normally Closed Output

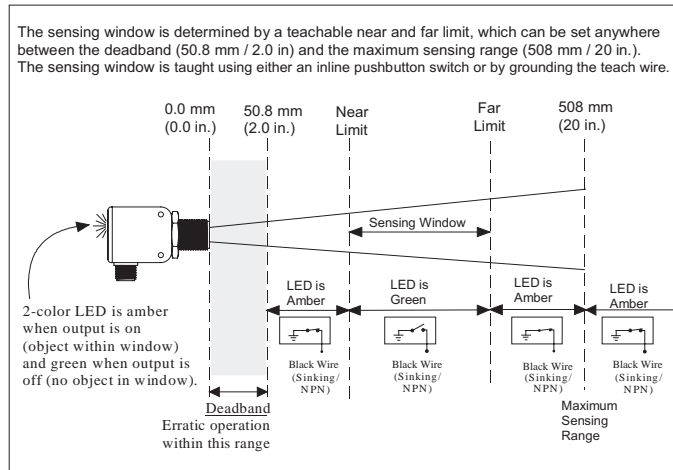

### PNP - Normally Open Output

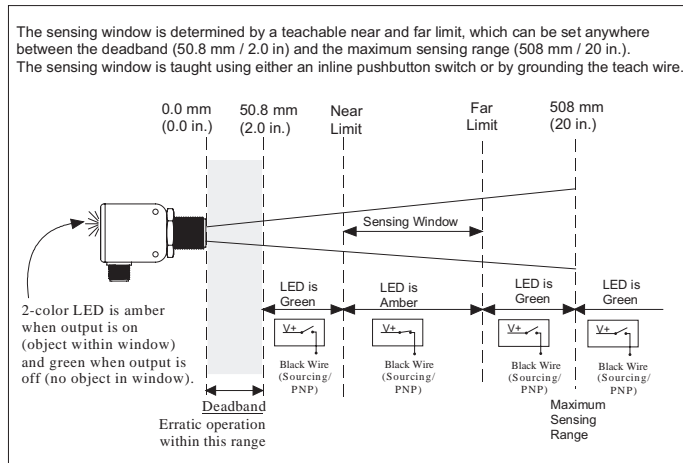

## Beam Plots

The following plots, developed from data collected at 20°C, zero air flow, defines the boundaries and shape of the sonic beam for the Virtu series sensors.

The boundaries were established using a 10 cm x 10 cm (3.94" x 3.94") "target" positioned parallel to the sensor face. The plot for each sensor series is valid for targets equal to or larger than 10 cm x 10 cm. Beam boundaries are determined by moving the large flat target into the beam while the plane of the target is held perpendicular to the beam axis.

In each sensor series, the plot extends from the end of the "deadband" on the left to the end of the sensing range on the right. The sensor is illustrated in the middle left margin.

These and other plots are available from Hyde Park upon request.

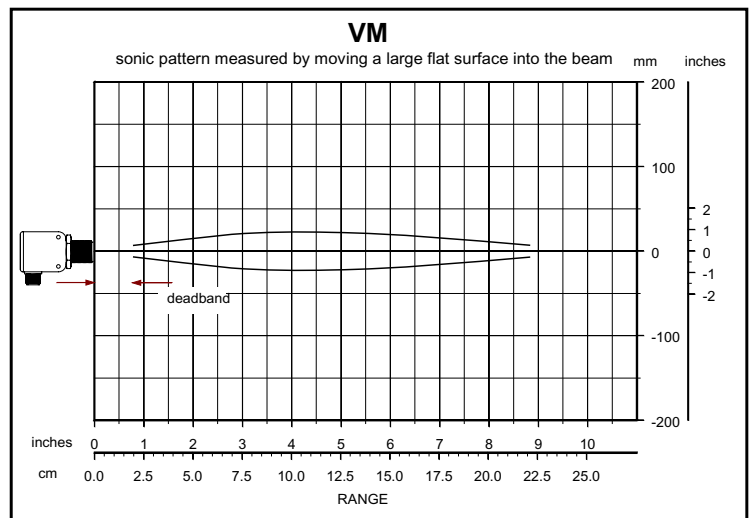

## Dimensions

### Quick Disconnect Style

(VALOX® Plastic) VM1-XXX-X

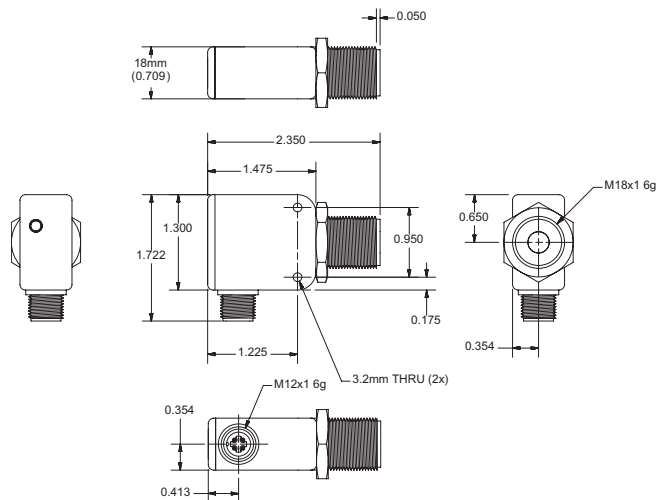

### 18 mm Barrel Style

(VALOX® Plastic) VM18-XXX-X

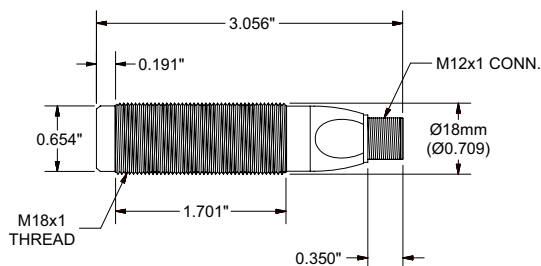

## Model Reference Guide - VM Series

Use the guide below to ensure the correct model number is specified for the application. Please note that not all sensor model combinations are available.

### EXAMPLE MODEL:

**Ultrasonic Miniature Proximity Series**

#### Model Type

- 1... Dual-mount, flat-profile
- 18... 18 mm barrel

#### Output Type

- N...NPN sinking output
- P... PNP sourcing output

#### Output Style

- NO...Normally open
- NC...Normally closed

#### Connection Types

- ...No designator indicates 3m (10') cable style connection\*
- Q...Quick disconnect – 4 pin “micro” connector

\* only available on the dual-mount body style

**VM 1 - P NO - Q**

## Accessories

**AC130** Straight, M12 micro, 4-conductor, connector/cable assembly, 5 m (16') (for barrel and flat-profile micro sensors)

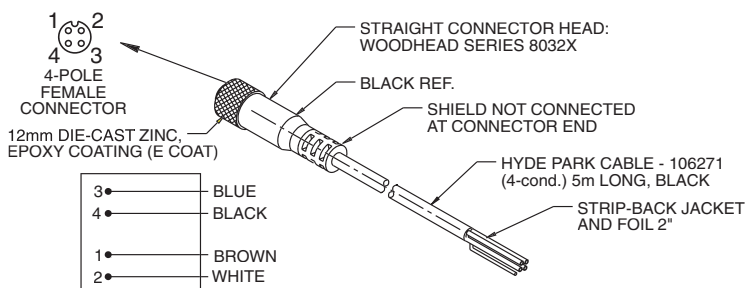

**PB100** In-line accessory push-button for teaching window limits (for Virtu series sensors).

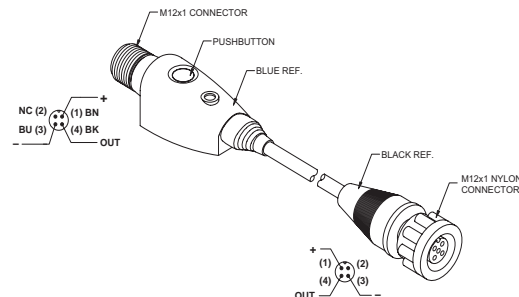

## General Specifications

### Sensing [T<sub>A</sub> = 20°C (68° F)]

Sensing Range:

50 mm (2") to 508 mm (20")  
(large flat objects)

Sonic Frequency: 300 kHz

Minimum-size Detection:

2.5 mm (0.098") diameter rod or 1.0 mm (.039")  
bar at a distance of 200 mm (8")

Note: Smaller object may not be detected at  
closer distances

Maximum Angular Deviation:

± 5° on a 100 mm x 100 mm (4" x 4")  
flat target at a distance of 508 mm (20")

Sonic Cone Profile:

see beam plot on page 3-3

Limit Position Accuracy:

± 1.6 mm (0.062") max.

Repeatability:

± 0.7mm (0.027") or better

### Power Requirements

Supply Voltage:

12VDC to 24VDC ± 10%, regulated supply

Current Consumption:

40 mA max. (excluding load)

Power Consumption:

1.0 W max. (excluding load)

### Output

Sinking Output (NPN Model VM1-NXX):

Maximum on-state voltage: 0.75 V @ 100 mA

Maximum load current: 100 mA

Maximum applied voltage: 30 VDC

Sourcing Output (PNP Model VM1-PXX):

Maximum on-state voltage drop: 1.10 V @ 100mA

Maximum load current: 100mA

Output voltage: V<sub>Supply</sub> - 1.10 V @ 100mA

### Input-Teach Setup

Contact Closure (push-button) to common. Internal  
115KΩ pull-up to 5V

Input Voltage Range

Setup Input Active 0V to 1V

Setup Input Inactive 2.5V to 5V

Max Voltage without Damage -30V to 30V

### Response Time

15.0 ms on/ 15.0 ms off max

### Indicators

Green LED: Illuminated if output is off

Amber LED: Illuminated if output is on

Note: Green and Amber LEDs are never illuminated  
simultaneously

### Connections

Cable style models:

24 AWG, foil shield, lead-free, PVC jacket  
4-conductor, 3m (10') long

Connector style models:

8 mm, circular 4-pole, male micro connector

### Protection

Power Supply: Current-limited over-voltage, ESD,  
reverse polarity

Output: Current-limited over-voltage, ESD, reverse  
polarity

Input: Current-limited over-voltage, ESD, reverse  
polarity

### Environmental

Operating Temperature Range:

-30° to 70°C (-22° to 152°F)

Storage Temperature Range:

-40° to 85°C (-40° to 185°F)

Operating Humidity: 100% non-condensing

Protection Ratings: NEMA 4X, IP67

Chemical Resistance: Resists most acids and  
bases, including most food products

See page 7-1 for accessory photos.

## Selection Chart

### VM Series Proximity

Model No.	Power Version 12/24 VDC		Conn. Style	Sensing		Materials			Outputs			Notes
	Cable	Quick Disconnect				Range	Window	Epoxy	Housing		Type	
			VALOX	PBT	NPN sinking				PNP sourcing	Normally open	Normally closed	
VM1-NNO	■	■		508 mm (20")	Teachable	■	■		■	■		
VM1-NNC	■	■		508 mm (20")	Teachable	■	■		■		■	
VM1-NNO-Q	■		■	508 mm (20")	Teachable	■	■		■	■		
VM1-NNC-Q	■		■	508 mm (20")	Teachable	■	■		■		■	
VM1-PNO	■	■		508 mm (20")	Teachable	■	■			■	■	
VM1-PNC	■	■		508 mm (20")	Teachable	■	■			■		■
VM1-PNO-Q	■		■	508 mm (20")	Teachable	■	■			■	■	
VM1-PNC-Q	■		■	508 mm (20")	Teachable	■	■			■		■
VM18-PNC	■	■		508 mm (20")	Teachable	■		■		■		■
VM18-PNO-Q	■		■	508 mm (20")	Teachable	■		■		■	■	
VM18-PNC-Q	■		■	508 mm (20")	Teachable	■		■		■		■
VM18-NNO	■	■		508 mm (20")	Teachable	■		■	■		■	
VM18-NNC	■	■		508 mm (20")	Teachable	■		■	■			■
VM18-NNO-Q	■		■	508 mm (20")	Teachable	■		■	■		■	
VM18-NNC-Q	■		■	508 mm (20")	Teachable	■		■	■			■
VM18-PNO	■	■		508 mm (20")	Teachable	■		■		■	■	

VIRTU™ VM SERIES

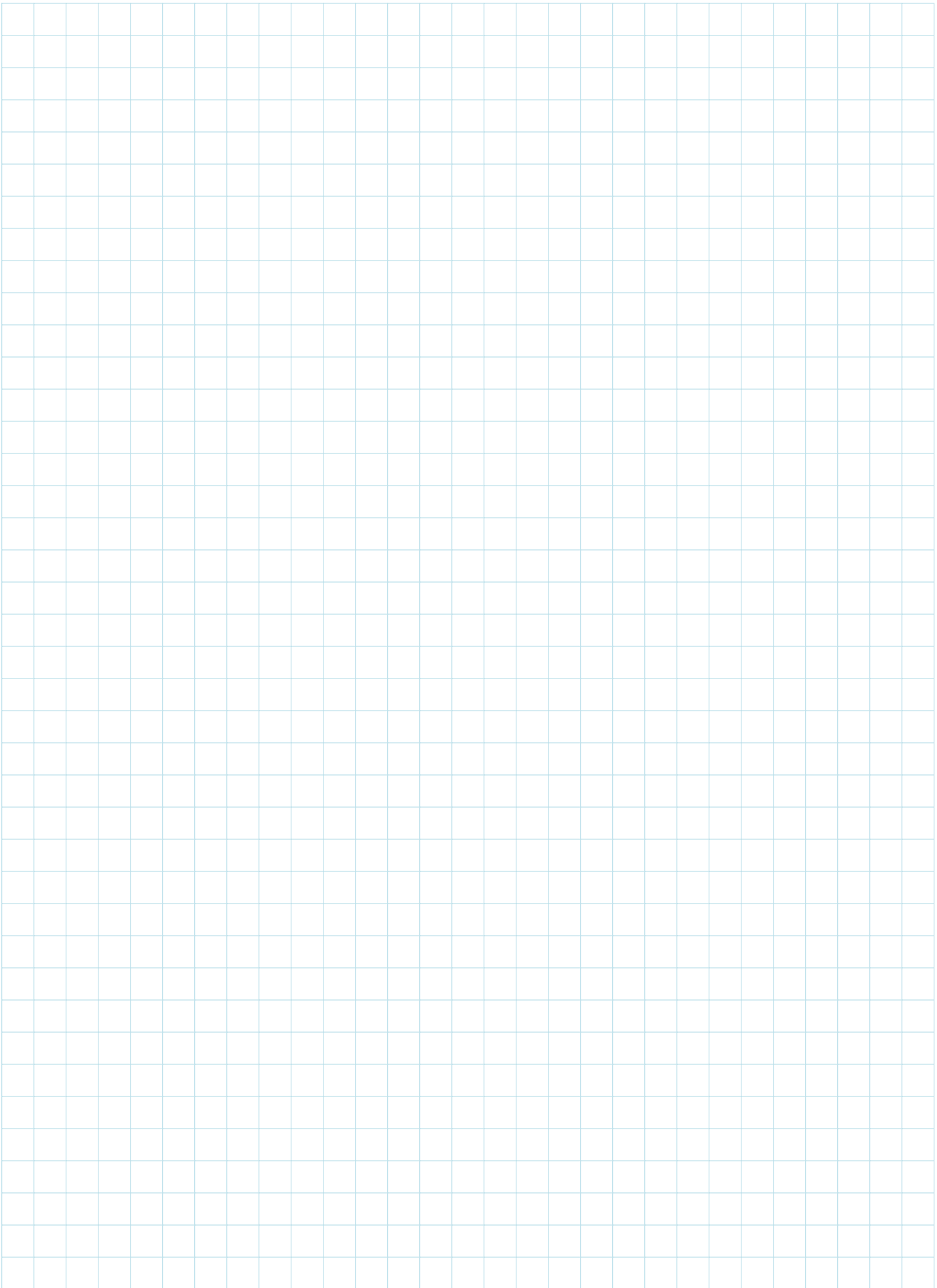





## VIRTU™ Analog Ultrasonic Sensors

**The next generation of compact ultrasonic analog sensors that outperforms many other sensor types in all types of applications.**

The new Virtu™ Analog ultrasonic sensor developed by Hyde Park features sensing ranges from 50.8 mm (2") up to 508 mm (20").

Virtu's dual-mount body style, with its M18 x 1 threaded snout 0.89" long and a 1.49" rectangular body for a total length of only 2.38", and tough VALOX® housing make it not only ideal for many OEM applications but also an unfailing performer for an array of packaging applications, including food and beverage. Available in cable or connector style, Virtu™ is the first sonic compact sensor to offer a dual mounting feature. It operates on 15 to 24 VDC. Virtu™ also has teach-in window capability, and no downtime is required for sensor recalibration when colors, materials, or shapes change.

With protection ratings of 4X and IP67, this CE certified sensor is resistant to dust, 100% humidity, most acids and bases, and high pressure washdowns that often leave water buildup on the sensing face. This sleek sensor is virtually impervious to the effects of splashing food, caustic cleaning solutions, and changing light conditions or colors. Shielding and filtering make the fully encapsulated sensor resistant to radiated or conducted energy.

### Operation

The Virtu™ Analog series is a self-contained, pulse-echo, analog sensing device that both transmits and receives sonic energy within a 508 mm (20") maximum sensing range. Operating on 15 to 24 VDC, and employing the latest piezoelectric and microprocessor technology, Virtu™ sensors detect only those designated objects within a set "window" and ignore all surrounding sonic interference.

Prior to operation, a simple and easy "teach" function is used to set the sensing window limits through either a remote or in-line cable push-button. A near and far limit for a desired sensing window can be set anywhere within the sensing range and may be set to either encompass the full sensing range or be as small as 6 mm (0.25").

The sensor is equipped with three LED's to show the sensing status. The amber LED is off when an object is within the sensing window. The green LED is on when an object is being sensed within the range of the sensor. The orange LED indicates the relative value of the analog output and varies in intensity according to the output. The higher the current or voltage output, the brighter the orange LED.

### Setting the Window Limits

Before operating the sensor, you should teach the sensor the sensing window. The sensing window is the distance between the near and far limits. To teach the limits, press and hold the push-button. The amber

- *Auto Slope technology, direct and inverse*
- *Sensing range of 50.8 mm (2") up to 508 mm (20")*
- *Dual-mount flat-profile body style and 18 mm barrel*
- *Rugged duty design for harsh environments*
- *Simple remote push-button accessory available for teaching of sensing limits*
- *4X, IP67*
- *CE certified*

LED fast flashes and then after holding the push-button for three seconds, the green LED slowly flashes indicating the sensor is in teach mode. Release the push-button, and the green LED continues slowly flashing indicating the sensor is waiting for the first limit. Place a target at the distance corresponding to the analog minimum (0 V or 4 mA), then press and release the push-button. While the push-button is pressed with a target present, the amber LED turns on indicating a valid echo is being detected. After teaching the sensor the first limit successfully, the amber LED slowly flashes indicating the sensor is waiting for the second limit. Place a target at the distance corresponding to the analog maximum (10 V or 20 mA), then press and release the push-button. While the push-button is pressed with a target present, the amber LED turns on indicating a valid echo is being detected. After teaching the sensor the second limit, the two limits are saved in non-volatile memory. The green LED fast flashes for 3 seconds to indicate the limits were successfully saved.

While setting either limit, if no echo is detected, the green and amber LED fast flashes indicating no object is detected. After 5 seconds, the sensor resumes operation with the old limits. If either limit is not set in 30 seconds, a limit timeout occurs, the LED flashes green and amber for 3 seconds indicating the error. The sensor then resumes operating with the old limits.

If not using an optional push-button, the process is similar. The white teach wire (pin 2) can be grounded to the blue DC return wire (pin 3) to simulate the pushing of the button. All LED indications and the teach sequence is identical to the previously detailed process.

## How Does It Work?

During teach and operation, the Virtu™ sensor continually and accurately measures the elapsed time from the first pulse echo received after each pulse transmission. The transmitted pulse begins a time clock to register the elapsed time of the first received pulse echo. Given the elapsed time, the sensor software calculates the distance traveled out to the object or surface and back to the sensor, using the formula  $D = TV_s/2$ , where: D = distance from the sensor to the object; T = elapsed time between the pulse transmission and its first received echo;  $V_s$  = the velocity of sound, approximately 335 meters (1100 feet) per second.

During operation, the calculated distance (D) between the sensor and the object is compared to the distances between the sensor and the analog span limits. These limits are shown in the illustration as  $D_{wi}$  and  $D_{wo}$ . If D is at or within the analog span limits, an output value for D, relative to the analog span limits is generated.

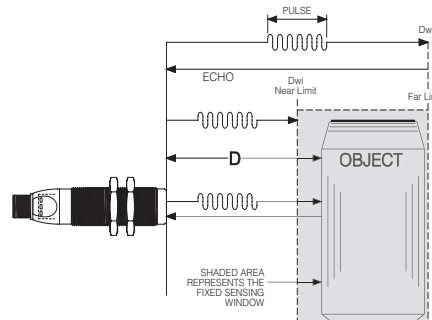

## Electrical Wiring

The sensor cable must be run in conduit, free of any AC power or control wires.

### Cable Style Model (dual mount model only)

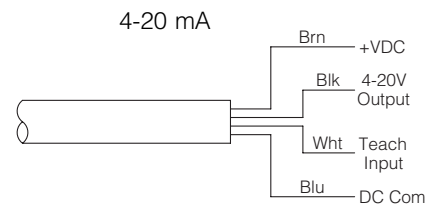
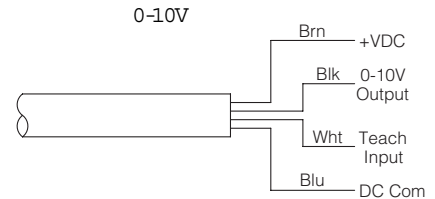

### Micro Connector Style 0-10 V

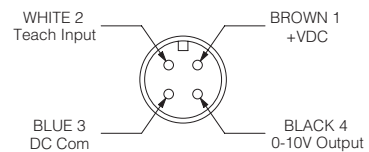

### 4-20 mA

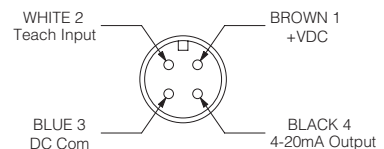



## Dimensions

### Quick Disconnect Style

(VALOX® Plastic) VM1-XXXXXX-Q

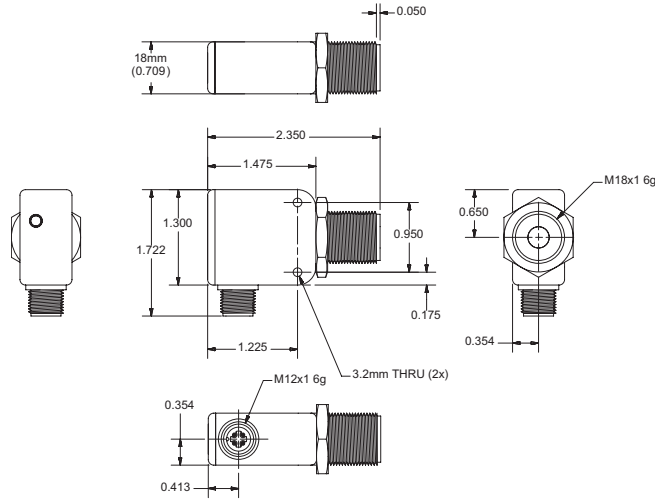

### 18 mm Barrel Style

(VALOX® Plastic) VM18-XXXXXX-Q

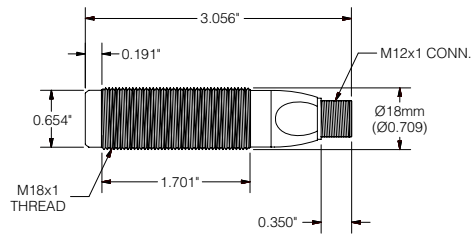

## Accessories

**AC130** Straight, M12 micro, 4-conductor, connector/cable assembly, 5 m (16')

**PB100** In-line accessory push-button for teaching window limits (for Virtu™ series sensors).

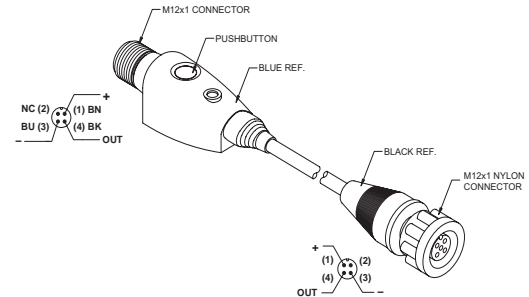
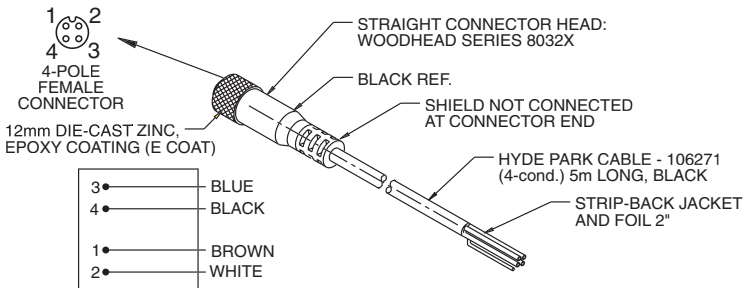

## General Specifications

**Sensing:** [ $T_a = 20^\circ\text{C}$  (68°F)] -Large Flat Target

Range:	50.8 mm (2.0 in.) to 508 mm (20 in.)
Maximum plane-reflector angle:	$\pm 5^\circ$
Sonic Cone Angle:	See beam plot
Window-edge accuracy:	$\pm 1.27$ mm (0.050 in.) @ constant temperature
Minimum object size Rod:	2.5 mm (0.098in) at 254.0 mm (10.0') range, 0° tilt
Factory Set sensing window Temperature Compensation	50.8 mm (2.0 in.) to 508 mm (20 in.) Temperature Compensated

### Power Requirements:

Supply Voltage:	+ 15 to 24 VDC ( $\pm 10\%$ ) @ 40 mA max (including output load)
Protection:	ESD and reverse-polarity

### Analog Output:

#### CA Models:

Output Range:	4-20 milliamps
Load resistance:	10 to 350 ohms
Protection:	ESD and short circuit

#### VA Models

Output Range:	0-10 volts
Load resistance:	2K ohms minimum
Protection:	ESD and short circuit

### Pushbutton Input:

Active voltage level:	< 1.0 volt
Inactive voltage level:	> 2.5 volts
Activation On/Off time:	> 25 ms (3 seconds to arm for limit setup)

### Response Time:

50 ms to 95% of final output value

### Indicators:

- Green LED: On when object is within range
- Amber LED: Off when object is within window
- Orange LED: Intensity varies directly with output magnitude

### Connections

- Cable style models: (VM1 only)
- 24 AWG, foil shield, lead-free, PVS jacket
- 4-conductor, 3m (10') long
- Connector style models:
- 12mm, circular 4-pole, male micro connector

### Protection

- Power Supply: Current-limited over voltage, ESD, reverse polarity
- Output: Current-limited over voltage, ESD, over current
- Input: Current-limited over voltage, ESD, reverse polarity

### Environmental:

- Operating Temperature:  $-30^\circ\text{C}$  to  $70^\circ\text{C}$  ( $-22^\circ\text{F}$  to  $158^\circ\text{F}$ )
- Storing Temperature Range:  $-40^\circ\text{C}$  to  $85^\circ\text{C}$  ( $-40^\circ\text{F}$  to  $185^\circ\text{F}$ )
- Operating Humidity: 100% non-condensing
- Protection Ratings: NEMA 4X, IP67
- Chemical Resistance: Resists most acids and bases, including most food products.

## Standard Model Reference Guide - Virtu™ Analog Series

The following models represent an analog minimum output state on loss of echo & power up as well as normal functionality.

VM1-VA  
VM1-VA-Q  
VM18-VA-Q

VM1-CA  
VM1-CA-Q  
VM18-CA-Q

### EXAMPLE MODEL:

**Analog Ultrasonic Series**

**Model Type**

1...Dual Mount

18..18 mm Barrel

**Output Type**

V...Voltage output (0-10 VDC default)

C...Current output (4-20 mA default)

**Output Style**

A...Auto slope (default)

**Connection Type**

...No designator indicates 3 m (10') cable style connection (not available in VM18 barrel)

Q...Quick disconnect - 4-pin M12 "Micro" connector

VM1-VA-Q

### Accessories

**Model PB100**, Inline push-button switch (for teaching window)

**Model AC130**, Straight, M12 micro, 4-conductor, connector/cable assembly, 5 m (16'), for micro-connector sensors

**Model AC132**, Right-angle, M12 micro, 4-conductor, connector/cable assembly, 5 m (16'), for micro-connector sensors

**Model AC228**, Right-angle bracket

See page 7-1 for accessory photos.

## Enhanced Reference Guide - Virtu™ Analog Series

Use the guide below to ensure the correct model number is specified for the application. Please note that not all sensor model combinations are available.

Enhanced models are programmed for a particular application. These sensors are available at a different cost premium compared to the standard models.

### EXAMPLE MODEL:

VM1-VA3000-\_\_Q

#### Analog Ultrasonic Series

#### Model Type

- 1...Dual Mount
- 18..18 mm Barrel

#### Output Type

- V...Voltage output (0-10 VDC default)
- C...Current output (4-20 mA default)

#### Output Style

- A...Auto slope (default)
- I...Inverse slope
- D...Direct slope

#### Output State for Loss of Echo & Power-up State

- 0...Analog minimum
- 1...Analog maximum
- 2...Hold on loss-of-echo; analog minimum on power-up
- 3...Hold on loss-of-echo; analog maximum on power-up

#### Functionality

- 000...Normal functionality
- 001...Foreground suppression only (object mode)
- 002...Foreground suppression only (background mode)
- 003...Foreground & background suppression (background mode)

#### Options

- ....No designator indicates no option
- AD.Teach function disabled

#### Connection Type

- ....No designator indicates 3 m (10') cable style connection (not available in VM18 mm barrel)
- Q....Quick disconnect - 4-pin M12 "Micro" connector

# Selection Chart

## VM Analog Series

Model No.	Materials					Outputs				Functionality				Notes
	Power Version 12/24 VDC	Quick Disconnect	Transducer Housing			Type				Functionality				
			Epoxy	VALOX	PBT	Analog Minimum	Analog Maximum	Hold on loss-of-echo, analog minimum on power-up	Hold on loss-of-echo analog maximum on power-up	Normal functionality	Foreground suppression (object mode)	Foreground suppression (background mode)	Foreground & background suppression (background mode)	
VM1-VA-Q	■	■	■	■	■	■				■				
VM1-VA0001-Q	■	■	■	■		■					■			
VM1-VA0002-Q	■	■	■	■								■		
VM1-VA0003-Q	■	■	■	■		■							■	
VM1-VA1000-Q	■	■	■	■			■			■				
VM1-VA1001-Q	■	■	■	■			■				■			
VM1-VA1002-Q	■	■	■	■			■					■		
VM1-VA1003-Q	■	■	■	■			■						■	
VM1-VA2000-Q	■	■	■	■				■		■				
VM1-VA2001-Q	■	■	■	■				■			■			
VM1-VA2002-Q	■	■	■	■				■				■		
VM1-VA2003-Q	■	■	■	■				■					■	
VM1-VA3000-Q	■	■	■	■					■					
VM1-VA3001-Q	■	■	■	■					■		■			
VM1-VA3002-Q	■	■	■	■					■			■		
VM1-VA3003-Q	■	■	■	■					■				■	
VM1-VI-Q	■	■	■	■		■				■				
VM1-VI0001-Q	■	■	■	■		■					■			
VM1-VI0002-Q	■	■	■	■		■						■		
VM1-VI0003-Q	■	■	■	■		■							■	
VM1-VI1000-Q	■	■	■	■			■			■				
VM1-VI1001-Q	■	■	■	■			■				■			
VM1-VI1002-Q	■	■	■	■			■					■		
VM1-VI1003-Q	■	■	■	■			■						■	
VM1-VI2000-Q	■	■	■	■				■		■				
VM1-VI2001-Q	■	■	■	■				■			■			
VM1-VI2002-Q	■	■	■	■				■				■		
VM1-VI2003-Q	■	■	■	■				■					■	
VM1-VI3000-Q	■	■	■	■					■					
VM1-VI3001-Q	■	■	■	■					■		■			
VM1-VI3002-Q	■	■	■	■					■			■		
VM1-VI3003-Q	■	■	■	■					■				■	
VM1-VD-Q	■	■	■	■		■				■				
VM1-VD0001-Q	■	■	■	■		■					■			
VM1-VD0002-Q	■	■	■	■		■						■		
VM1-VD0003-Q	■	■	■	■		■							■	
VM1-VD1000-Q	■	■	■	■			■			■				
VM1-VD1001-Q	■	■	■	■			■				■			
VM1-VD1002-Q	■	■	■	■			■					■		
VM1-VD1003-Q	■	■	■	■			■						■	
VM1-VD2000-Q	■	■	■	■				■		■				
VM1-VD2001-Q	■	■	■	■				■			■			
VM1-VD2002-Q	■	■	■	■				■				■		
VM1-VD2003-Q	■	■	■	■				■					■	
VM1-VD3000-Q	■	■	■	■					■					
VM1-VD3001-Q	■	■	■	■					■		■			
VM1-VD3002-Q	■	■	■	■					■			■		
VM1-VD3003-Q	■	■	■	■					■				■	

\*(The VM1 dual-mount style models are also available in 10' cable length)

# Selection Chart

## VM Analog Series (cont.)

Model No.	Materials					Outputs				Functionality				Notes
	Power Version 12/24 VDC	Quick Disconnect	Transducer Housing			Type				Functionality				
			Epoxy	VALOX	PBT	Analog Minimum	Analog Maximum	Hold on loss-of-echo, analog minimum on power up	Hold on loss-of-echo analog maximum on power up	Normal functionality	Foreground suppression (object mode)	Foreground suppression (background mode)	Foreground & background suppression (background mode)	
VM18-VA-Q	■	■	■	■	■	■				■				
VM18-VA0001-Q	■	■	■	■	■	■					■			
VM18-VA0002-Q	■	■	■	■	■	■						■		
VM18-VA0003-Q	■	■	■	■	■	■							■	
VM18-VA1000-Q	■	■	■	■	■		■			■				
VM18-VA1001-Q	■	■	■	■	■		■				■			
VM18-VA1002-Q	■	■	■	■	■		■					■		
VM18-VA1003-Q	■	■	■	■	■		■						■	
VM18-VA2000-Q	■	■	■	■	■			■		■				
VM18-VA2001-Q	■	■	■	■	■			■			■			
VM18-VA2002-Q	■	■	■	■	■			■				■		
VM18-VA2003-Q	■	■	■	■	■			■					■	
VM18-VA3000-Q	■	■	■	■	■				■	■				
VM18-VA3001-Q	■	■	■	■	■				■		■			
VM18-VA3002-Q	■	■	■	■	■				■			■		
VM18-VA3003-Q	■	■	■	■	■				■				■	
VM18-VI-Q	■	■	■	■	■	■				■				
VM18-VI0001-Q	■	■	■	■	■	■					■			
VM18-VI0002-Q	■	■	■	■	■	■						■		
VM18-VI0003-Q	■	■	■	■	■	■							■	
VM18-VI1000-Q	■	■	■	■	■		■			■				
VM18-VI1001-Q	■	■	■	■	■		■				■			
VM18-VI1002-Q	■	■	■	■	■		■					■		
VM18-VI1003-Q	■	■	■	■	■		■						■	
VM18-VI2000-Q	■	■	■	■	■			■		■				
VM18-VI2001-Q	■	■	■	■	■			■			■			
VM18-VI2002-Q	■	■	■	■	■			■				■		
VM18-VI2003-Q	■	■	■	■	■			■					■	
VM18-VI3000-Q	■	■	■	■	■				■	■				
VM18-VI3001-Q	■	■	■	■	■				■		■			
VM18-VI3002-Q	■	■	■	■	■				■			■		
VM18-VI3003-Q	■	■	■	■	■				■				■	
VM18-VD-Q	■	■	■	■	■	■				■				
VM18-VD0001-Q	■	■	■	■	■	■					■			
VM18-VD0002-Q	■	■	■	■	■	■						■		
VM18-VD0003-Q	■	■	■	■	■	■							■	
VM18-VD1000-Q	■	■	■	■	■		■			■				
VM18-VD1001-Q	■	■	■	■	■		■				■			
VM18-VD1002-Q	■	■	■	■	■		■					■		
VM18-VD1003-Q	■	■	■	■	■		■						■	
VM18-VD2000-Q	■	■	■	■	■			■		■				
VM18-VD2001-Q	■	■	■	■	■			■			■			
VM18-VD2002-Q	■	■	■	■	■			■				■		
VM18-VD2003-Q	■	■	■	■	■			■					■	
VM18-VD3000-Q	■	■	■	■	■				■	■				
VM18-VD3001-Q	■	■	■	■	■				■		■			
VM18-VD3002-Q	■	■	■	■	■				■			■		
VM18-VD3003-Q	■	■	■	■	■				■				■	





## New tiny, ultrasonic sensors second to none in efficient, extended-range proximity sensing

For the first time in sensing history, Hyde Park makes available to OEMs and end users in almost every industry, a prox sensor that combines small size and extended sensing range to detect virtually any material without adjustment of any kind. This new SUPERPROX® 300 series represents the first reliable, “install-it-and-forget-it” replacement for inductive and fixed-field photoelectric sensors in solving industry-wide proximity sensing problems.

The threaded, 2 mm diameter and flat-profile housing allows the sensor to be easily embedded in a machine where larger, longer-range proximity sensors may not fit. Like other Hyde Park sensors, the SUPERPROX® 300 series is not affected by such contaminants as oil, dirt, water, powder, splashing food, dust, caustic cleaning solutions, and frequent wash-downs in the reliable detection of all materials. Objects of different and changing colors, shapes, and composition are all candidates for these tiny sensors whether they are transparent or opaque, liquid or solid. All this with no sensor adjustment of any kind required.

## Field Programmable Sensor

SUPERPROX+® software combined with the Model AC441A configurator interface module enables the SUPERPROX® 300 series sensors to be programmed by the user with either standard or custom sensing configurations. These field programmable sensors use an ‘SC’ prefix in the model number to designate and differentiate the sensors from factory configured SUPERPROX® 300 series models.

All the unique sensing capabilities and functions available in the SUPERPROX® SM300 sensor series are also available in field programmable SC300 models. An even greater sensing capability in functionality is realized with these field programmable sensor models through the user-friendly SUPERPROX+™ software to allow customization for specific applications.

For more details on the Model SC300 series and other field programmable sensor models along with the Model AC441A configurator interface module go to the SUPERPROX+™ section found on page 4-145 in the catalog.

## 12 mm & Flat-Profile Ultrasonic Sensors

SUPERPROX®  
Model SM300 Series  
*Proximity Sensing*

Model SM302 Series  
*Dual-level Sensing*

- *Field programmable capability*
- *CE certified*

## Operation

Combining the latest piezoelectric and microprocessor technology, the new SUPERPROX® 300 series sensors are self-contained, pulse-echo devices that both transmit and receive sonic energy within a set extended sensing range. During operation, the sensor continuously transmits to and receives sonic pulses from objects in front of it. Pulse echoes received from objects within the fixed sensing window limits are confirmed as detected objects by a discriminating microprocessor while all other objects are ignored.

## Easy to Set Up

Setting up the SUPERPROX® 300 series of proximity sensors for operation requires but a few moments. Once mounted in a bracket and properly aligned with the object to be detected, the sensor is ready to detect. It is truly a “set and forget” series of proximity sensors.

## How does it work?

During setup and operation, the SUPERPROX® 300 series sensors continually and accurately measure the elapsed time of every pulse transmission. The transmitted pulse begins a time clock to determine the elapsed times for the received pulse echoes. Given the elapsed time, the sensor software calculates the distance traveled out to the object and back to the sensor, using the formula,  $D = TVs/2$ , where  $D$  = distance from the sensor to the object;  $T$  = elapsed time between the pulse transmission and its echo reception;  $V_s$  = velocity of sound, approximately 1100 feet per second.

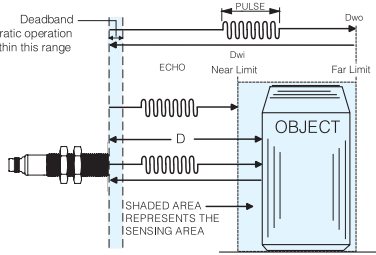

During operation, the calculated distance ( $D$ ) between the sensor and the object is compared to the distances between the sensor and the fixed window limits. These limits are shown in the illustration as  $D_{wi}$  and  $D_{wo}$ . If  $D$  is at or within the limits, an output change takes place and remains unchanged until the echo either does not return or it returns from outside the fixed limits.

## Applications

For applications specific to the SUPERPROX® 300 series sensors, see either the product information sections that follow or the Application/Sensor Selection Chart on Page 2-1.

## Beam Plot

The following plot, developed from data collected at 20°C, zero air flow, defines the boundaries and shape of the sonic beam for the SUPERPROX® 300 series sensors.

The boundaries were established using a 10 cm x 10 cm (3.94" x 3.94") "target" positioned parallel to the sensor face. This plot is valid for targets equal to or larger than 10 cm x 10 cm. Beam

boundaries are determined by moving the large flat target into the beam while the plane of the target is held perpendicular to the beam axis.

In this sensor series, the plot extends from the end of the "deadband" on the left to the end of the sensing range on the right. The sensor is illustrated in the middle left margin.

This and other plots are available from Hyde Park upon request.

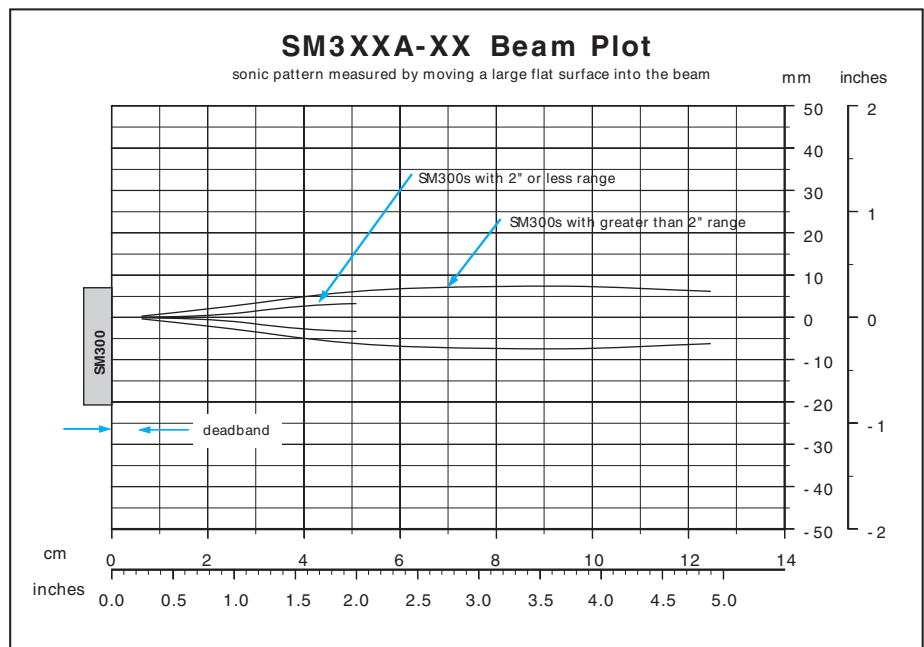
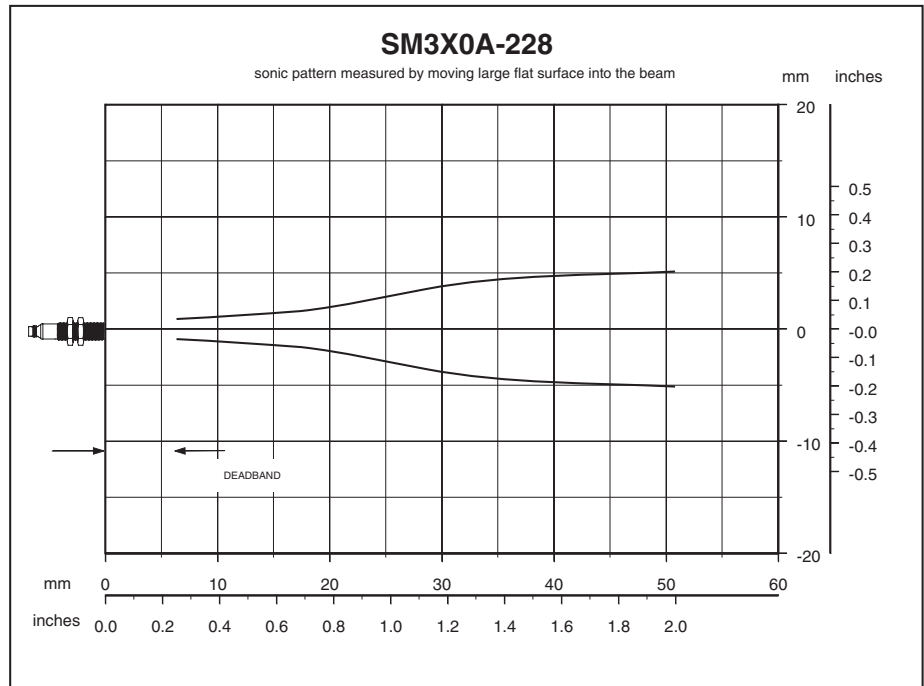

## Model SM300 Series



### SUPERPROX® Ultrasonic Proximity Sensors

#### Extended-range Proximity Sensing

- Self-contained, 12 mm, threaded barrel or flat-profile housing
- Extended sensing range of 102 mm (4")
- Field programmable capability
- All-material, proximity sensing capability
- CE certified

#### The world's first 12 mm and flat-profile, long-range, multi-material, ultrasonic, proximity sensor... the efficient solution to close-up sensing

Use the highly versatile SUPERPROX® Model SM300 series of proximity sensors as a replacement for inductive proximity sensors and fixed-field photoelectric sensors. Its long range, small size, fast response, performance, reliability, and low cost, offers a simple, easy to use, once-and-for-all solution to many of the proximity sensing problems encountered daily in almost every industry.

The SM300 proximity sensor provides reliable detection of objects up to 102 mm (4") from the sensor face, performance unmatched by other proximity sensors of the same size or larger. At this distance, the sensor is safely out of harm's way, an especially important cost savings benefit. Easy to install, the SM300 is available in two different housing styles: the 12 mm threaded barrel or the flat-profile housing both available in ULTEM® plastic. As with all SUPERPROX® sensors, cable and connector styles are available.

The SM300 is inherently capable of automatically detecting all materials regardless of color, shape, and composition (transparent or opaque, liquid or solid) including clear glass, mirrors, wood, powder, ink, ferrous and nonferrous metal, plastics, and objects that change colors. While some sensors require adjustment (through the use of a sensitivity potentiometer) to the

material they are detecting, the SM300 detects most materials automatically. With protection ratings of NEMA 4X and IP67, the sensor resists most acids and bases and is compatible with many chemicals, cleaning solutions, and chemical-based products. The SM300 sensor series is CE certified.

These are just a few of the benefits of this new, small, multi-material, extended-range proximity sensor from the world leader in ultrasonic sensing technology.

The applications suited to the SM300 proximity sensor are as broad as the benefits just mentioned. And because of the sensor's versatility, it is a solid candidate for almost every proximity sensing and noncontact switching need in the plant. The SM300 can detect positive stop and true home positions for servo-control systems and tool and parts presence in automated CNC centers and assembly equipment. It is an ideal solution for sensing part and pin presence along with punch-through verification in stamping dies. Other applications include die open and closed detection of stamping, plastic injection molding, and die casting applications. Or, anywhere that traditional proximity sensing methods cannot reliably detect the large variety of materials running through the process or are limited by range.

#### Operation

The SUPERPROX® Model SM300 series is a self-contained, pulse-echo, proximity sensing device that both transmits and receives sonic energy within an operating distance of 6 mm

(0.25") to 102 mm (4"). The sensor combines the latest piezoelectric and microprocessor technology for the best possible performance in almost any sensing application.

This 500 kHz proximity sensor operates on 12 to 24 VDC and is equipped with both sinking (NPN) and sourcing (PNP) outputs. The sensor has two status LEDs: an amber LED indicates "power on" when no object is present, and an orange LED indicates object presence, regardless of output state (N.O. or N.C.). Just one LED is illuminated at any given time.

During operation, the sensor transmits to and receives sonic pulses from objects in front of it without interruption. A discriminating microprocessor makes it possible for the sensor to accept only those pulse echoes received from objects within the fixed sensing window limits and ignore all other objects. An object is detected when it is within the fixed sensing window.

## How does it work?

During setup and operation, the SM300 series sensor continually and accurately measures the elapsed time of every pulse echo reception after each pulse transmission. The transmitted pulse starts a time clock to register the elapsed time for the received pulse echoes. Given the elapsed time, the sensor software calculates the distance traveled to the object or surface and back to the sensor, using the formula,  $D = Tv_s/2$ , where  $D$  = distance from the sensor to the object;  $T$  = elapsed time between the pulse transmission and its echo reception,  $V_s$  = the velocity of sound, approximately 1100 feet per second.

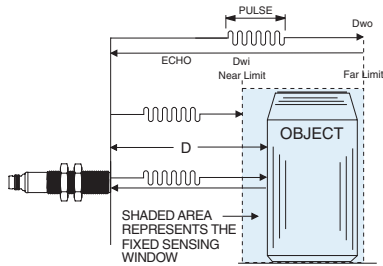

While the sensor is in operation, the calculated distance ( $D$ ) between the sensor and the object is compared to the distances associated with the fixed window limits. These limits are shown in the illustration above as  $D_{wi}$  and  $D_{wo}$ . If  $D$  is within these limits, an output is generated. The output remains on until the echo does not return or it returns from outside the window limits.

## Mounting & Setting up the SM300 Proximity Sensor

The SM300 series proximity sensor should be mounted in a bracket that allows it to be adjusted for proper alignment with the object. Set up for optimum object sensing and sensitivity merely involves positioning the sensor so the sonic beam is aligned with and perpendicular to the surface of the object being detected and the object is at or near the center of the sensing window. Once the sensor is mounted, no other adjustments are required.

Note: Small objects are best detected at 38 mm (1.5").

## Electrical Wiring

The sensor cable must be run in conduit, free of any AC power or control wires.

## Outputs

### NPN Sinking and PNP Sourcing

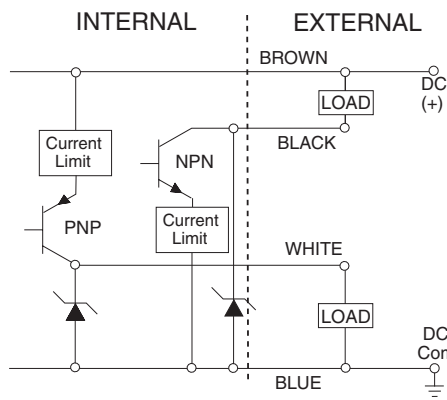

### Cable Style Wire Assignments

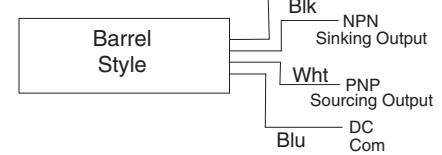

### Connector Style Pin Assignments

#### SM350

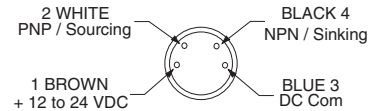

Note: Sensor view: Pico connector

#### SM380

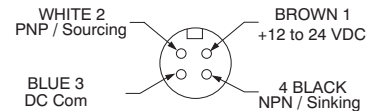

Note: Sensor pigtail view: Micro connector

#### SM330/SM340

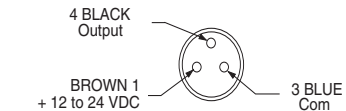

Note: Sensor view: Pico connector

### Normally Open Output

The sensor output is on with the object in the fixed sensing window.

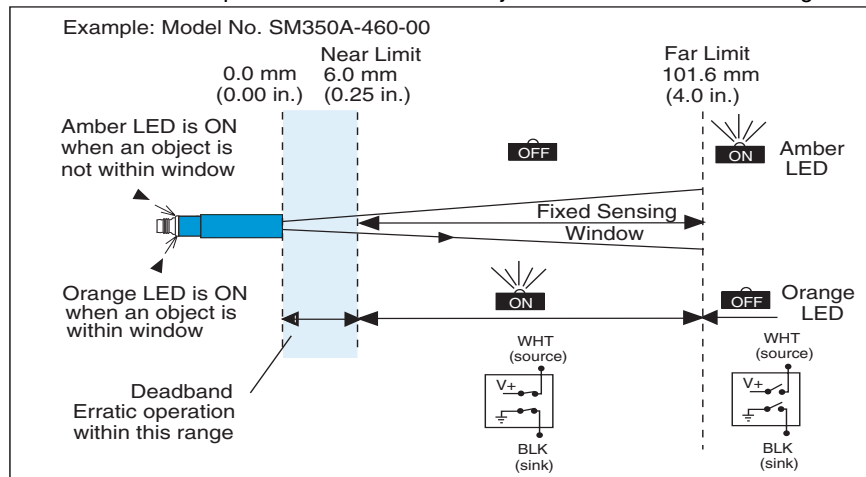

### Normally Closed Output

The sensor output is off with the object in the fixed sensing window.

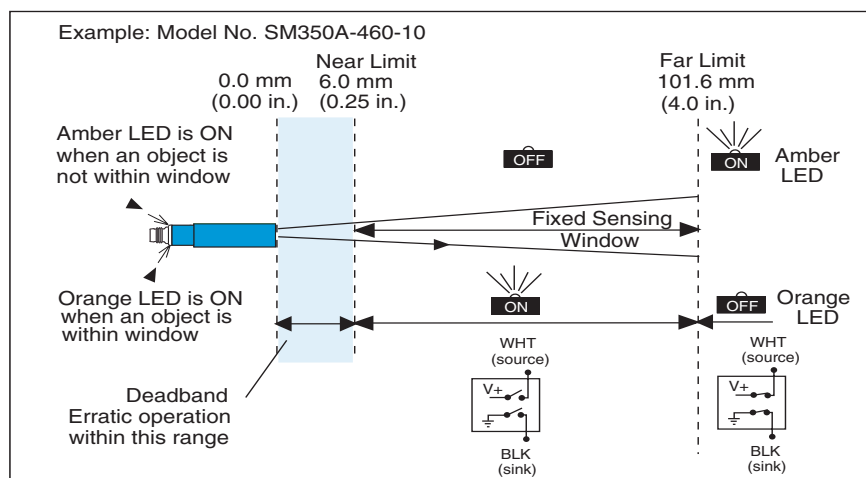

**SM300A-XXX-00FP - Special Window**

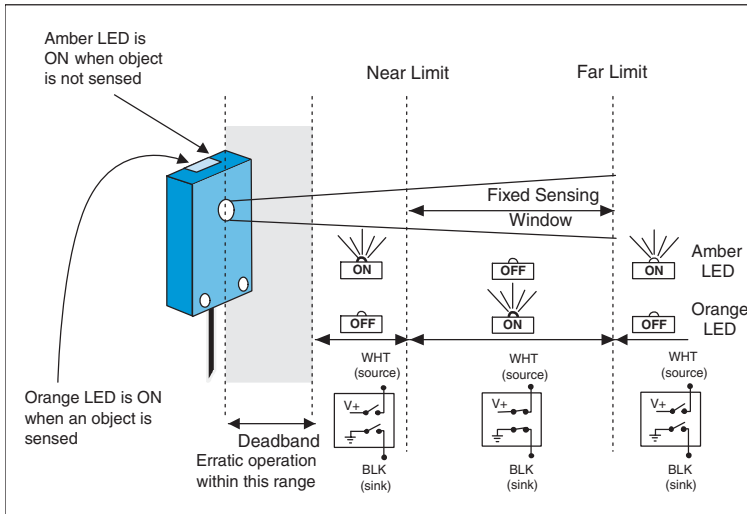

**Model Reference Guide - SM300 Series**

Use the guide below to ensure the correct model number is specified for the application. Please note that not all sensor model combinations are available.

**EXAMPLE MODEL:**

**SM3 5 0 A - 2 28 - 00**

**Ultrasonic Miniature Proximity Series**

**Power/Connection Type**

- 0...12 to 24 VDC / Cable style
- 3...12 to 24 VDC / 3-pin "Pico" connector w/PNP output
- 4...12 to 24 VDC / 3-pin "Pico" connector w/NPN output
- 5...12 to 24 VDC / 4-pin "Pico" connector
- 6...12 to 24 VDC / 4-pin "Pico" connector - output pins reversed
- 8...12 to 24 VDC / 4-pin "Micro" connector
- 9...12 to 24 VDC / 4-pin "Micro" connector - output pins reversed

*Flat-profile sensors with a connector and threaded barrel sensors*

*with a "Micro" connector have a 152 mm (6") pigtail*

**Sensing Function**

- 0...Proximity - No on/off delay

**Design Level**

- A...Applies to all models

**Sensing Range (Far Limit)**

- 2...50.8 mm (2.0")
- 3...67.2 mm (3.0")
- 4...101.6 mm (4.0")

**Sensing Window (Distance from Near Limit to Far Limit)**

*Note: Window should be less than range*

- 04...6.4 mm (0.25")
- 08...13 mm (0.5")
- 12...19 mm (0.75")
- 16...25.4 mm (1.0")
- 28...44.5 mm (1.75")
- 32...50.8 mm (2.0")
- 44...70 mm (2.75")
- 60...95.3 mm (3.75")

**Functionality**

- 00...N.O. output
- 10...N.C. output

**Options**

...Absence of designator indicates no options

**Housing Types**

- ...No designator indicates standard ULTEM® plastic -12 mm barrel housing
- FP...ULTEM® Flat-profile housing

\*ULTEM® is a registered trademark of The General Electric Company.

LEADER CHANGE HAS BEEN IMPLEMENTED  
New LED  
Amber  
Green  
Current LED  
Orange  
Amber

**SUPERPROX® SM300 SERIES**

## Dimensions

### Barrel Cable Micro Style

(ULTEM® Plastic) SM380A-XXX-XX

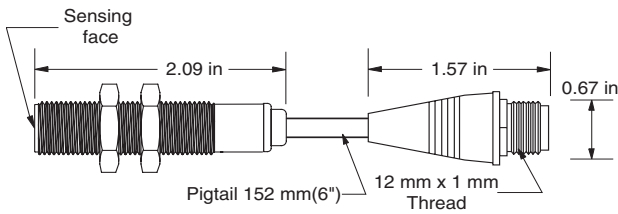

### Barrel Connector Style

(ULTEM® Plastic) SM350A-XXX-XX

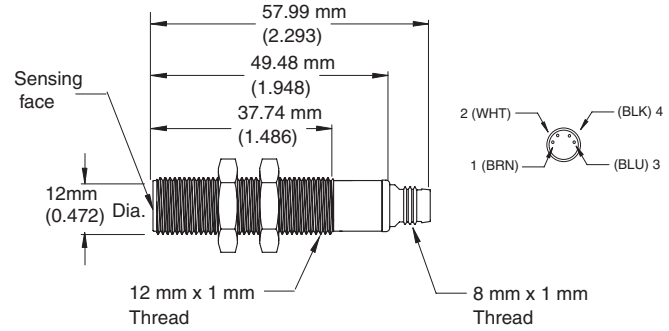

### Flat-profile Cable/Connector Style

(ULTEM® Plastic) SM300A-XXX-XXFP

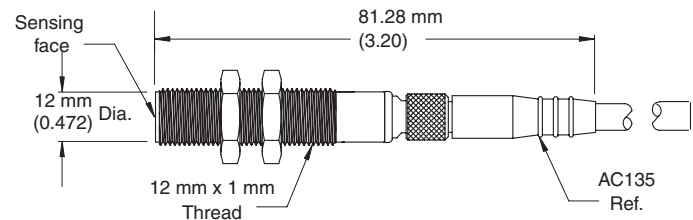
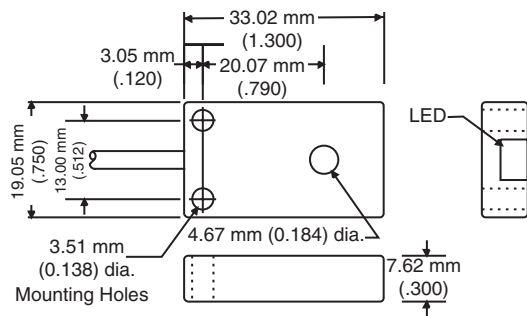

### Flat-profile Pico Connector Style

(ULTEM® Plastic) SM330FP, SM340FP, SM350-XX-XXXFP

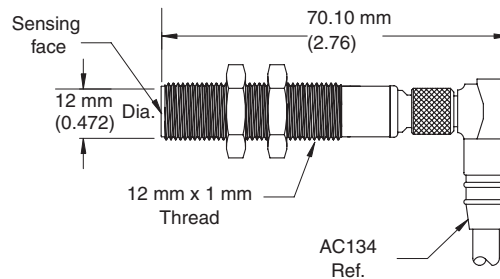
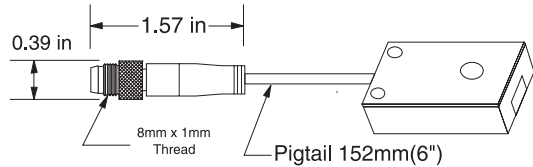

### Flat-profile Micro Connector Style

(ULTEM® Plastic) SM380A-XXX-XXFP

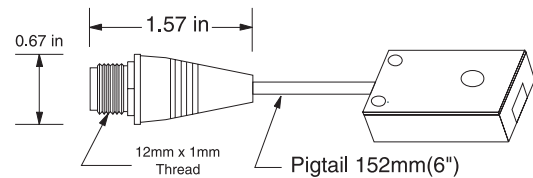

## Accessories

**AC130** Straight, M12 micro, 4-conductor, connector/cable assembly, 5 m (16') (for barrel and flat-profile micro sensors)

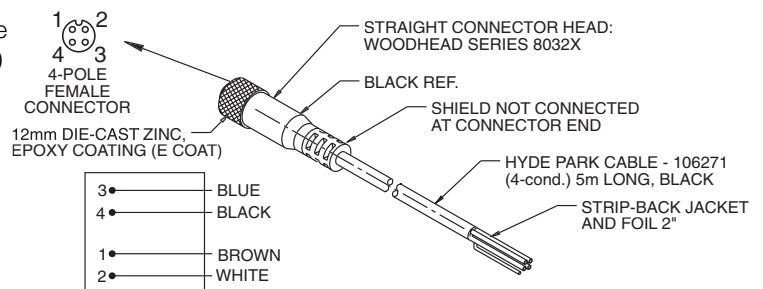

**AC134**

Right-angle, M8 pico, 4-conductor cable/connector assembly, 5 m (16').

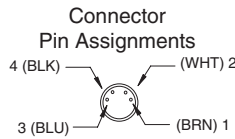
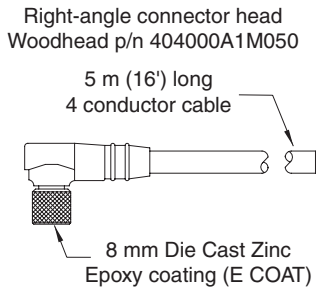

**AC135**

Straight, M8 pico, 4-conductor cable/connector assembly, 5 m (16').

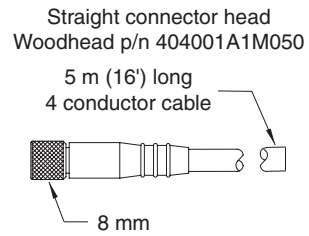

**AC141**

Right-angle, M8 pico, 3-conductor cable/connector assembly, 5 m (16') (for barrel connector-style sensors)

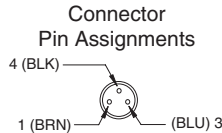
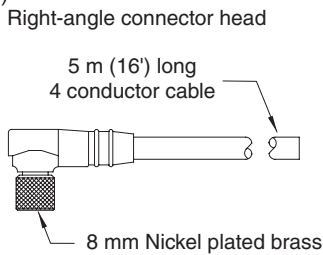

**AC142**

Stright, M8 pico, 3-conductor cable/connector assembly, 5 m (16') (for barrel connector-style sensors)

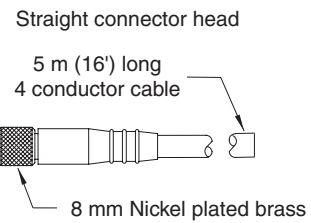

**AC235**

Right-angle, stainless, mounting bracket (for 12 mm barrel sensors)

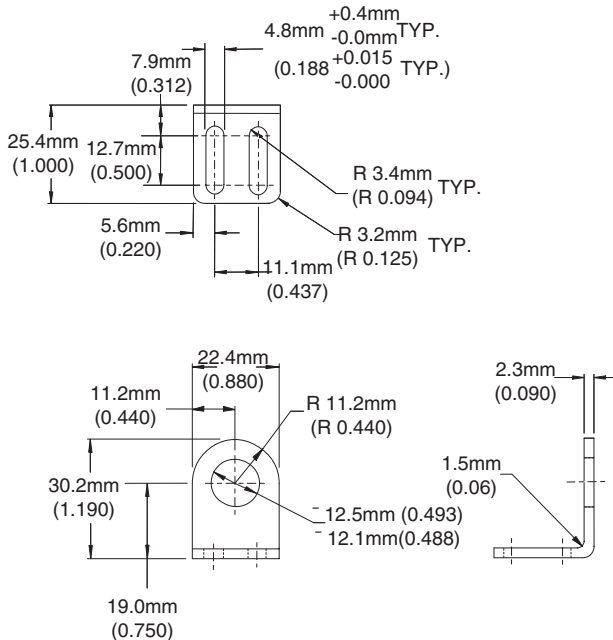

**AC236**

Stainless and polyamide conveyor-rail clamp/bracket set (for 12 mm barrel sensor)

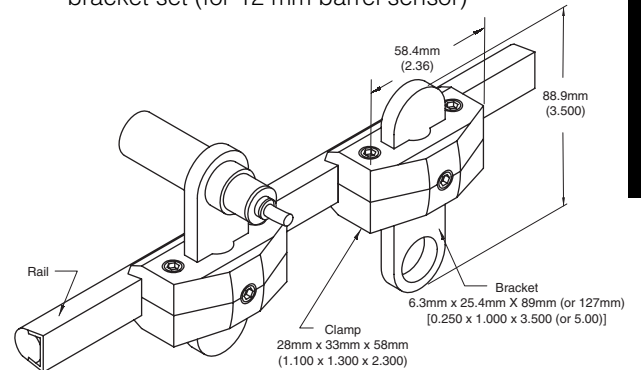

**AC237**

Straight, stainless, mounting bracket (for 12 mm barrel sensors)

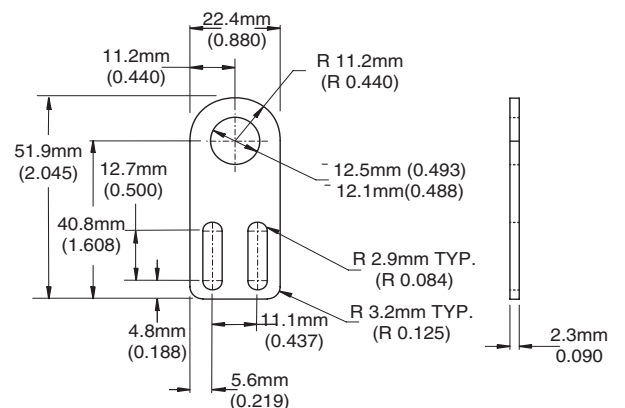

**SUPERPROX® SM300 SERIES**

## AC246

Right-angle, stainless, mounting bracket (for flat-profile style prox sensors)

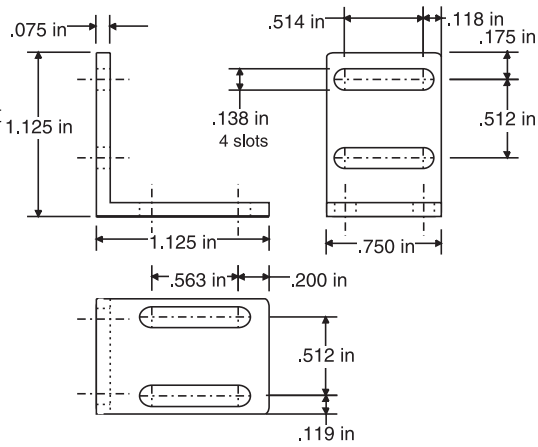

## AC247

Stainless and polyamide conveyor-rail clamp/bracket set (for flat-profile sensor)

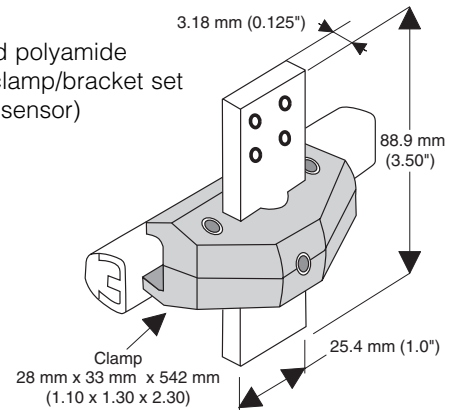

## General Specifications

### Sensing [T<sub>A</sub> = 20°C (68°F)]

Sensing Range:

6.4 mm (0.25") to 102 mm (4.0")  
(large flat objects)

Highest sensitivity over the range 38.1 mm  
(1.5") to 102 mm (4.0")

Sonic Frequency: 500 kHz

Minimum-size Detection:

2.5 mm (0.098") diameter rod or 1.0 mm  
(0.039") wide flat bar at a distance of 38 mm  
(1.5")

Note: Smaller object may not be detected at  
closer distances

Maximum Angular Deviation:

± 8° on a 100 mm x 100 mm (4" x 4") flat  
target at a distance of 89 mm (3.5")  
(4" range flat-profile)

Sonic Cone Profile:

see beam plot on page 4-2

Limit Position Accuracy:

± 1.6 mm (0.062") max.

Repeatability:

± 0.7 mm (0.027") or better

### Power Requirements

Supply Voltage:

12VDC to 24VDC ± 10%, regulated supply

Current Consumption:

25 mA max. (excluding load)

Power Consumption:

0.5 W max. (excluding load)

### Output

Sinking Output (NPN):

Maximum on-state voltage: 0.75 V @ 100 mA

Maximum load current: 100 mA

Maximum applied voltage: 30 VDC

Sourcing Output (PNP):

Maximum on-state voltage drop: 1.10 V @

100mA

Maximum load current: 100mA

Output voltage: V<sub>Supply</sub> - 1.10 V @ 100mA

### Response Time

2.0 ms on/ 2.0 ms off (2" range barrel unit)

3.0 ms on/ 3.0 ms off (2" range flat-profile unit)

4.0 ms on/ 4.0 ms off (4" range flat-profile unit)

### Indicators

Amber LED: Illuminated if power applied and  
no object detected

Orange LED: Illuminated if object is detected  
within the window, regardless of output polarity  
(N.O./N.C.) style.

Note: Amber and orange LEDs are never  
illuminated simultaneously

### Connections

Cable Style Models:

28 AWG, foil shield, lead-free, PVC jacket

4-conductor, 3M (10') long

Connector Style Models:

8 mm, circular 4-pole, male

Flat-profile pigtail 152 mm (6.0") long

micro-connector

### Protection

Power Supply: Current-limited over-voltage, ESD,  
reverse polarity

Outputs: Current-limited over-voltage, ESD,  
reverse polarity, over-current

### Environmental

Operating Temperature Range:

-30° to 70°C (-22° to 152°F) @ 12V supply

-30° to 65°C (-22° to 149°F) @ 24V supply

Storage Temperature Range:

-40° to 100°C (-40° to 212°F)

Operating Humidity: 100%

Protection Ratings: NEMA 4X, IP67

Chemical Resistance: Resists most acids and  
bases, including most food products.

### Agency Approvals

CE Mark: CE conformity is declared to:

EN60947:1998 (proximity sensors)

EN61010-1 (general safety)

EMC:

FCC 47 CFR Part 15 Class A (USA)

EN5022:1994 / A2:1997 Class A ITE (EU)

VCCI Class A ITE (Japan)

AS/NZS 3548:1995 / CISPR 22 Class A ITE

(Australia)

*Declaration of Conformity available upon request*

### Construction

Dimensions:

Barrel

Cable Model: 12 mm (0.472") dia. x 1 mm-6g

threaded housing x 53.3 mm (2.10") long

Connector Model: 12 mm (0.472") dia. x 1

mm-6g threaded housing x 55 mm (2.17")

long;

Overall length, including right angle, connector/  
cable assembly: 67.6 mm (2.66")

Flat-profile

Cable/Connector Model: 33.0 mm (1.3") H x

7.62 mm (0.3") W x 19.05 mm (0.75") L

Housing:

Shock and vibration resistant

Case: ULTEM® plastic (FDA Approved)

Transducer Face: Epoxy

Sensor Cable: Lead-free, PVC jacketed, black  
LED light ring: Polycarbonate

\* ULTEM® is a registered trademark of The General Electric  
Co.

## Accessories

**Model AC130**, Straight, M12 micro, 4-conductor,  
connector/cable assembly, 5 m (16'), for micro-  
connector sensors

**Model AC132**, Right-angle, M12 micro, 4-  
conductor, connector/cable assembly, 5 m (16'),  
for flat-profile connector-style sensors

**Model AC134**, Right-angle, M8 pico, 4-conductor,  
connector/cable assembly, 5 m (16') for barrel and  
flat-profile connector-style prox sensors

**Model AC135**, Straight, M8 pico, 4-conductor,  
connector/cable assembly, 5 m (16') for barrel and  
flat-profile connector-style prox sensors

**Model AC137**, Nano-to-micro pigtail adapter cable  
for barrel connector-style prox sensors

**Model AC138**, Nano-to-micro pigtail adapter cable,  
output pins reversed for barrel connector-style  
prox sensors

**Model AC141**, Right-angle, M8 pico, 3-conductor,  
connector/cable assembly, 5 m (16') for flat-profile  
connector-style sensors

**Model AC142**, Straight, M8 pico, 3-conductor,  
connector/cable assembly, 5 m (16') for flat-profile  
connector-style sensors

**Model AC235**, Right-angle, stainless, mounting  
bracket for barrel connector-style prox sensors

**Model AC236**, Stainless and polyamide conveyor-  
rail clamp/bracket set for barrel connector-style  
prox sensors

**Model AC237**, Straight, stainless, mounting bracket  
for barrel connector-style prox sensors

**Model AC242**, 18 mm to 12 mm hex mounting  
adapter

**Model AC243**, 30 mm to 12 mm hex mounting  
adapter

**Model AC246**, Right-angle, stainless, mounting  
bracket for flat-profile style prox sensors

**Model AC247**, Stainless and polyamide conveyor-

See page 7-1 for accessory photos.



# Selection Chart

## SM300 Series Proximity

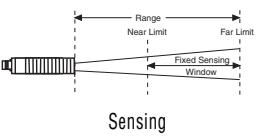
Model No.	Power Version 12/24 VDC	Conn. Style				Materials			Functionality		Notes
		Cable	Connector			Transducer	Housing		N.O. output	N.C output	
				Epoxy	12 mm ULTEM®	Flat-profile					
Range	Window										
SM300A-228-00	■	■		50.8 mm (2.0")	44.5 mm (1.75")	■	■		■		
SM300A-228-10	■	■		50.8 mm (2.0")	44.5 mm (1.75")	■	■			■	
SM300A-228-00FP	■	■		50.8 mm (2.0")	44.5 mm (1.75")	■		■	■		
SM300A-416-00FP	■	■		101.6 mm (4.0")	25.4 mm (1.0")	■		■	■		
SM300A-460-00FP	■	■		101.6 mm (4.0")	95.3 mm (3.75")	■		■	■		
SM330A-460-00FP	■		■	101.6 mm (4.0")	95.3 mm (3.75")	■		■	■		3-pin "PICO" (8 mm) connector with PNP output only
SM340A-460-00FP	■		■	101.6 mm (4.0")	95.3 mm (3.75")	■		■	■		3-pin "PICO" (8 mm) connector with NPN output only
SM350A-228-00	■	■		50.8 mm (2.0")	44.5 mm (1.75")	■	■		■		4-pin "PICO" (8 mm) connector
SM350A-228-10	■	■		50.8 mm (2.0")	44.5 mm (1.75")	■	■			■	4-pin "PICO" (8 mm) connector
SM380A-228-00	■	■		50.8 mm (2.0")	44.5 mm (1.75")	■	■		■		4-pin "MICRO" (12 mm) connector
SM380A-460-00	■		■	101.6 mm (4.0")	95.3 mm (3.75")	■	■		■		4-pin "MICRO" (12 mm) connector
SM350A-228-00FP	■		■	50.8 mm (2.0")	44.5 mm (1.75")	■		■	■		4-pin "PICO" (8 mm) connector
SM350A-416-00FP	■		■	101.6 mm (4.0")	25.4 mm (1.0")	■		■	■		4-pin "PICO" (8 mm) connector
SM350A-460-00FP	■		■	101.6 mm (4.0")	95.3 mm (3.75")	■		■	■		4-pin "PICO" (8 mm) connector
SM350A-460-10FP	■		■	101.6 mm (4.0")	95.3 mm (3.75")	■		■		■	4-pin "PICO" (8 mm) connector
SM380A-228-00FP	■		■	50.8 mm (2.0")	44.5 mm (1.75")	■		■	■		4-pin "MICRO" (12 mm) connector
SM380A-460-00FP	■		■	101.6 mm (4.0")	95.3 mm (3.75")	■		■	■		4-pin "MICRO" (12 mm) connector

All possible sensor configurations are not listed here.

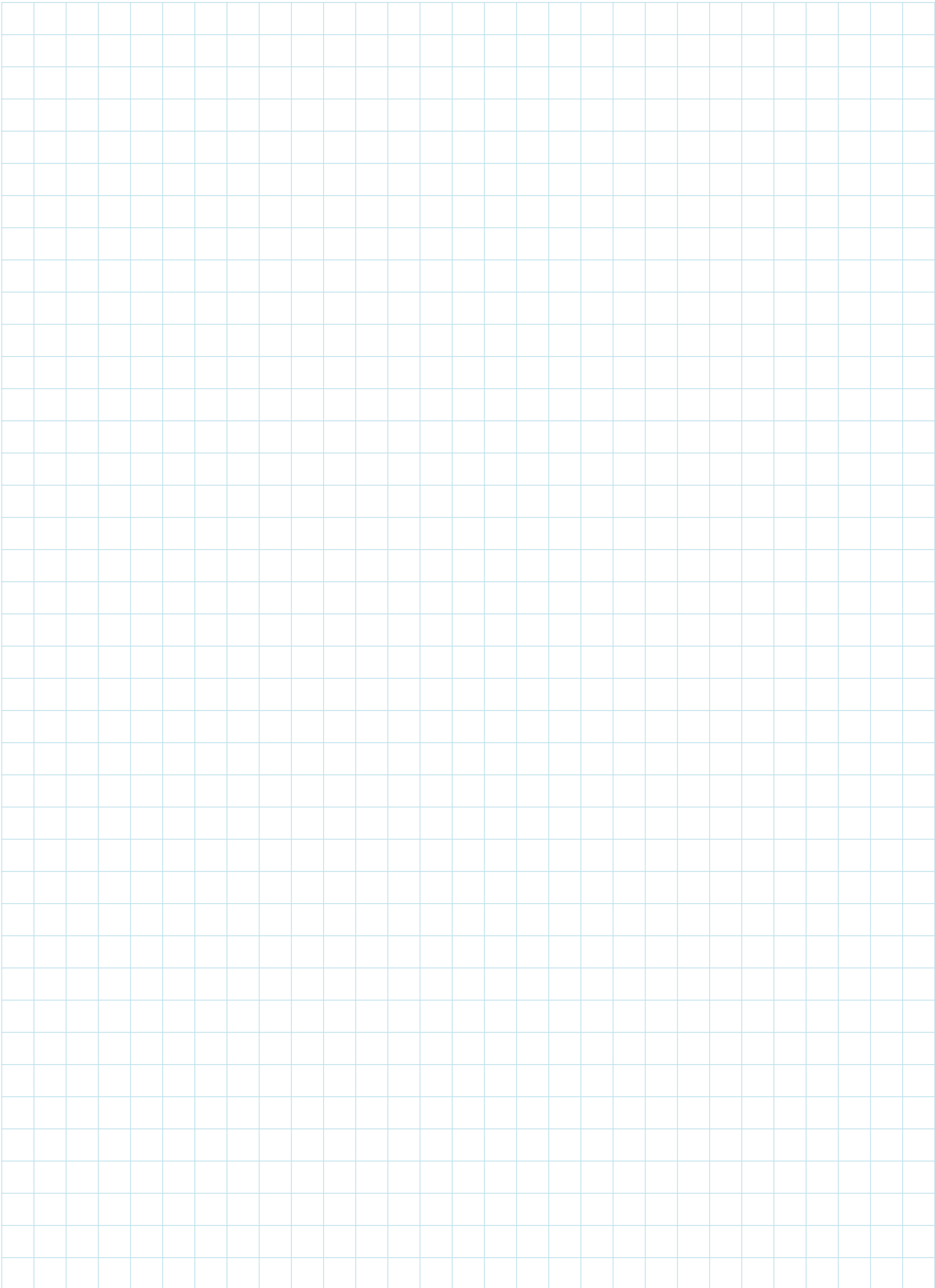

## Model SM302 Series

### SUPERPROX<sup>®</sup> Ultrasonic Dual-Level Sensors



**Two styles of reliable ultrasonic sensors offer short range sensing solutions for dual-level control applications where mounting space is very limited**

Functionality of the versatile, industry-proven SUPERPROX<sup>®</sup> Model SM502 series is now part of the Model SM302 series of 12 mm or flat-profile, dual-level sensors. Utilizing the same world-leading, ultrasonic technology, these two styles of “smart” sensors can be selected for specific on/off latch control functions. Other model selections include a variety of output types, response times, sensing ranges, and functionality to provide the sensing solution for a wide assortment of noncontact, short-range, dual-level control applications.

#### Operation

Hyde Park's 12 mm barrel and flat-profile style of self-contained, dual-level sensors monitor and control most nonhazardous liquid or dry material levels within a sensing range of 31.7 mm (1.25") to 101 mm (4").

When selecting by model number from several factory-programmed, dual-limit parameters (near limit and far limit), the sensor can be set up to perform an on/off latch control function.

The 12 mm threaded barrel and the flat-profile style housing are available in ULTEM<sup>®</sup> plastic. Both provide ease-of-installation convenience, particularly in applications with hard-to-mount or limited-space mounting areas. All models in this sensor series operate on 12 to 24 VDC regulated power.

The Model SM302 sensor series offers dependable operation and compatible integration with most programmable logic controllers. Each sensor is epoxy sealed to withstand harsh, wet, messy, and dusty environments typically associated with level-control applications. With protection ratings of NEMA 4X and IP67, both sensor styles are impervious to changing light conditions, colors, noise, noncondensing humidity, caustic chemicals, and other hostile environments. They are resistant to most acids and bases, including most food products. The sensing transducer is made of silicone rubber and the sensors carry the CE mark.

- High resolution 500 kHz ultrasonic frequency
- Self-contained, 12 mm barrel or flat-profile housing styles
- Dual-level on/off latch
- Field programmable capability in 12 mm and flat-profile models
- CE certified

SUPERPROX<sup>®</sup> SM302  
SERIES

## How does it work?

During setup and operation, these SM302 series sensors continually and accurately measure the elapsed time of every pulse echo reception between each pulse transmission. The transmitted pulse begins a time clock to register the elapsed times for the received pulse echoes. Given the elapsed time, the sensor software calculates the distance traveled out to the object or surface and back to the sensor, using the formula,  $D = Tv_s/2$ , where: D = distance from the sensor to the object; T = elapsed time between the pulse transmission and its echo receptions,  $V_s$  = the velocity of sound, approximately 1100 feet per second.

During operation, the calculated distance (D) between the sensor and the object (e.g., level) is compared to the distance between the sensor and the near and far span limits. These limits are shown in the illustration below as Dwi and Dwo. When D is equal to one of the two span limits, according to the level-control functions, an output change takes place.

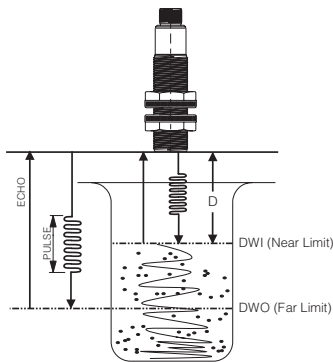

## Level-Control Functions

The level-control output in the Model SM302 series can be configured for one of two different operating functions. Using the Model Reference Guide, the sensor can be selected to perform either a pump-in level-control function or pump-out level-control function.

### Pump-in Level Control

When the level moves beyond the far limit, the sensor level control output switches state and latches, starting a pump-in process. The sensor level control output does not change state until the level moves back beyond the near limit to stop the pumping or filling process.

### Pump-out Level Control

When the level moves beyond the far

state and latches, stopping a pump-out process. The sensor level control output does not change state until the level moves back beyond the near limit to restart the pump-out process.

## Loss of Echo Operation

### Output Off on Loss of Echo

Loss of echo occurs when the sensor does not receive echoes from an object within its sensing range for more than one second. When this occurs, the sensor's output automatically switches OFF. When the sensor again receives echoes, the output assumes the state relative to the control limit setpoints.

### Output Holds on Loss of Echo ("LE" Option)

The LE suffix indicates an available option for users who do not prefer the standard response to loss of echo. With the LE option, when loss of echo occurs, there is no change in the output state of the sensor. When the sensor again receives echoes, the output assumes the state relative to the control limit setpoints.

## Mounting

The Model SM302 series sensors should be mounted in brackets that allow them to be adjusted for proper alignment. Hyde Park offers the Model AC235 right angle, stainless mounting bracket, Model AC236 stainless and polyamide conveyor-rail clamp/bracket set, Model AC237 stright, stainless, mounting bracket. All are illustrated with dimensions on Pages 4-14 and 4-15.

## Electrical Wiring

The sensor wires must be run in conduit free of any AC power or control wires.

### Connector Model Pin Assignments

On/Off Latch Outputs, SM352

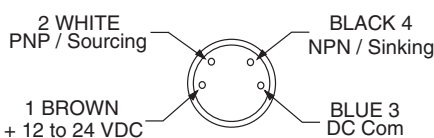

Note: Sensor view: Pico connector

### Connector Model Pin Assignments

On/Off Latch Outputs, SM382

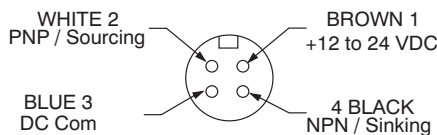

Note: Sensor pigtail view: Micro connector

### Connector Model Pin Assignments

On/Off Latch Outputs, SM332 & SM342

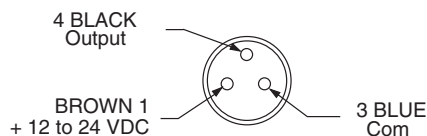

Note: Sensor view: Pico connector

## NPN/Sinking and PNP/Sourcing Outputs

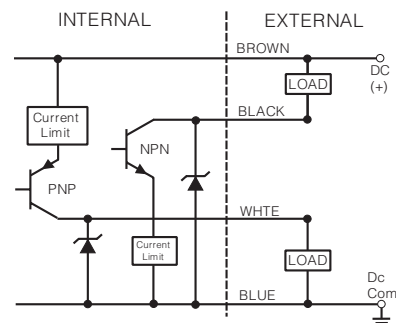

## Model Reference Guide - SM302 Series

Use the guide below to ensure the correct model number is specified for the application. Please note that not all sensor model combinations are available.

### EXAMPLE MODEL:

**SM3 5 2 A - 4 20 - 00**

#### SUPERPROX® Product Series

#### Power/Connection Type

0...12 to 24 VDC / cable style

3...12 to 24 VDC / 3-pin pico connector w/PNP output

4...12 to 24 VDC / 3-pin pico connector w/NPN output

5...12 to 24 VDC / 4-pin pico connector

6...12 to 24 VDC / 4-pin pico connector reversed outputs

8...12 to 24 VDC / 4-pin micro connector

9...12 to 24 VDC / 4-pin connector reversed outputs

*Flat-profile sensors with a connector and threaded barrel sensors with a micro connector have a 152 mm (6") pigtail.*

#### Sensing Function

2...Proximity - dual-level

#### Design Level

A...Applies to all DC-powered models

#### Sensing Range (Far Limit)

2...50.8 mm (2.0")

3...76.2 mm (3.0")

4...102 mm (4.0")

#### Sensing Window (Distance from Far Limit to Near Limit)

**NOTE:** Must be less than range. Specify in sixteenths.

12...19 mm (0.75")

16...25.4 mm (1.0")

20...31.75 mm (1.25")

32...51.8 mm (2.0")

#### Functionality

00...N.O. output, pump-out latch

10...N.O. output, pump-in latch

#### Options

... No designator indicates no options

LE...No change in output on loss of echo

#### Housing Types

... No designator indicates standard ULTEM® plastic 12 mm barrel housing.

FP...ULTEM® Flat-profile housing

\* ULTEM is a registered trademark of the General Electric Company.

SUPERPROX® SM302 SERIES

## Sensor Operating Profiles

### Pump-out Level Control

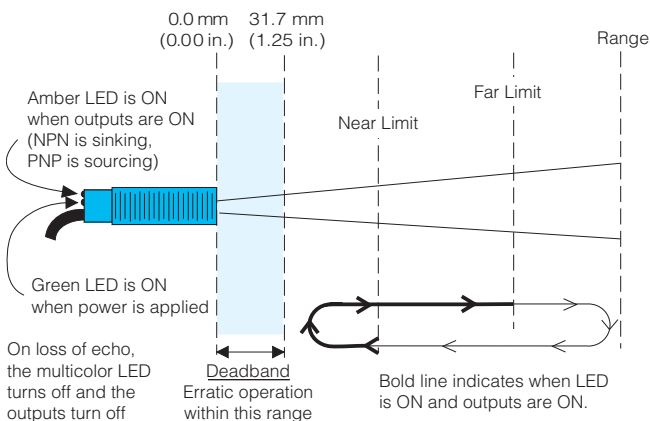

### Pump-in Level Control

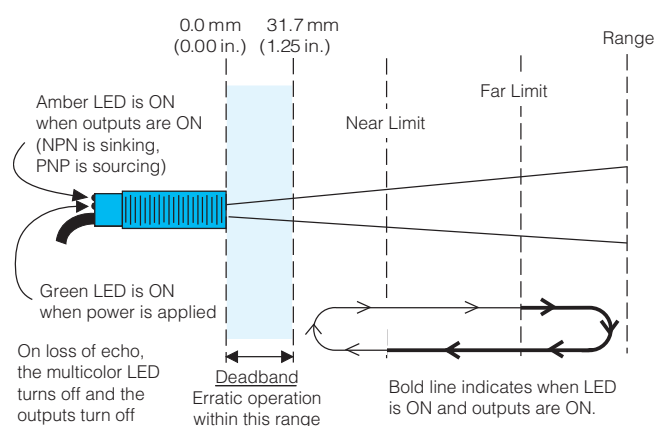

## Dimensions

### Barrel Cable Micro Style

(ULTEM® Plastic) SM382A-XXX-XX

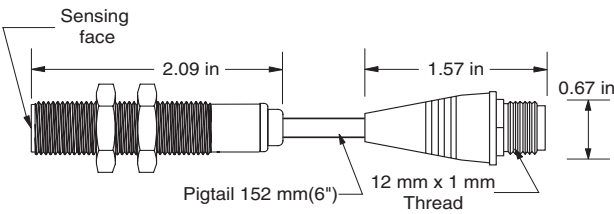

### Barrel Connector Style

(ULTEM® Plastic) SM332, SM 342, SM352A-XXX-XX

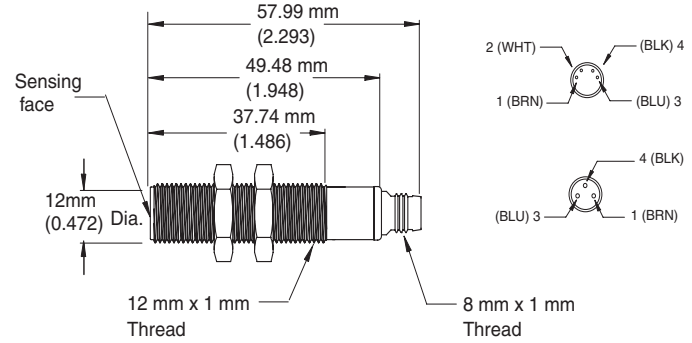

### Flat-profile Cable/Connector Style

(ULTEM® Plastic) SM302A-XXX-XXFP

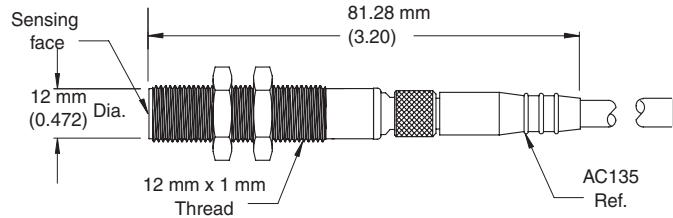
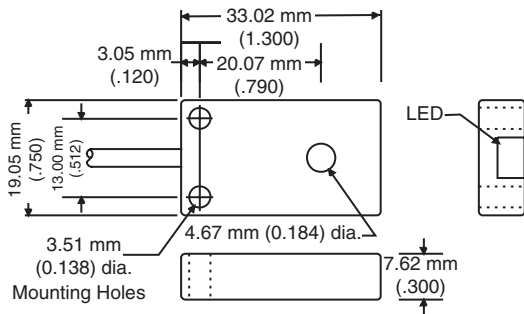

Flat-profile pico connector style  
(ULTEM® plastic) SM332FP, SM342FP, SM352-XX-XXXFP

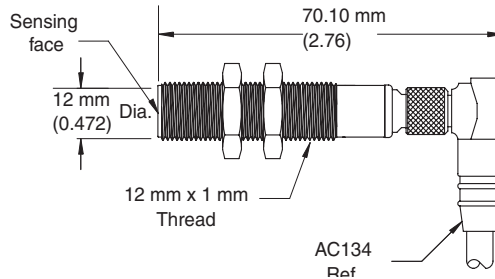
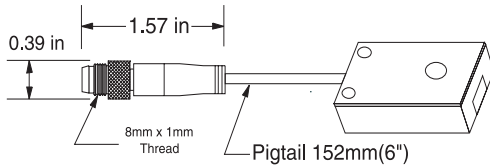

Flat-profile micro connector style  
(ULTEM® plastic) SM382A-XXX-XXFP

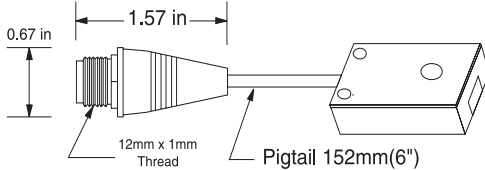

## Accessories

**AC130** Straight, M12 micro, 4-conductor, connector/cable assembly, 5 m (16') (for barrel and flat-profile micro sensors)

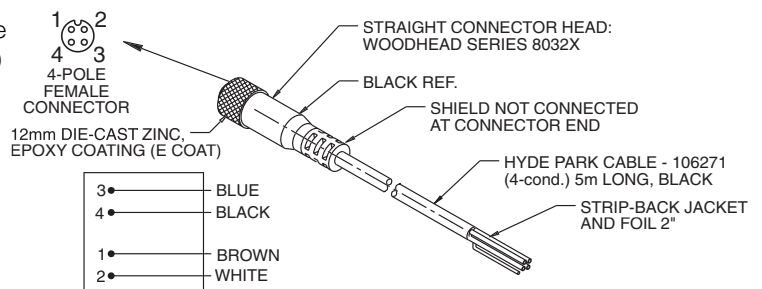

### AC134

Right-angle, M8 pico, 4-conductor cable/  
connector assembly, 5 m (16').

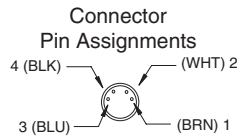
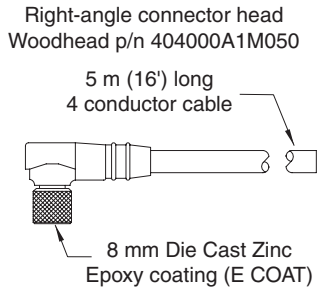

### AC135

Straight, M8 pico, 4-conductor cable/  
connector assembly, 5 m (16').

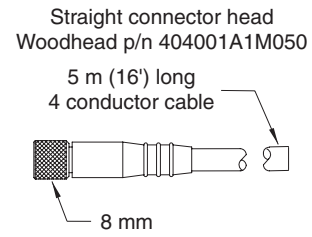

### AC141

Right-angle, M8 pico, 3-conductor cable/connector  
assembly, 5 m (16') (for barrel connector-style  
sensors)

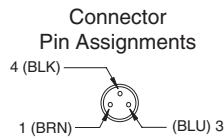
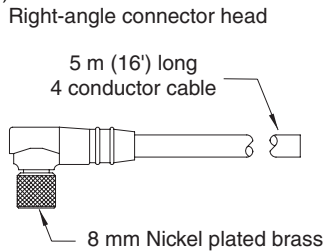

### AC142

Straight, M8 pico, 3-conductor cable/connector  
assembly, 5 m (16') (for barrel connector-style  
sensors)

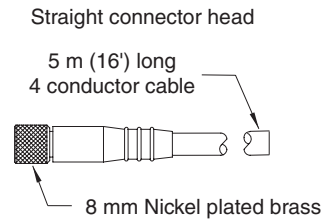

### AC235

Right-angle, stainless, mounting bracket  
(for 12 mm barrel sensors)

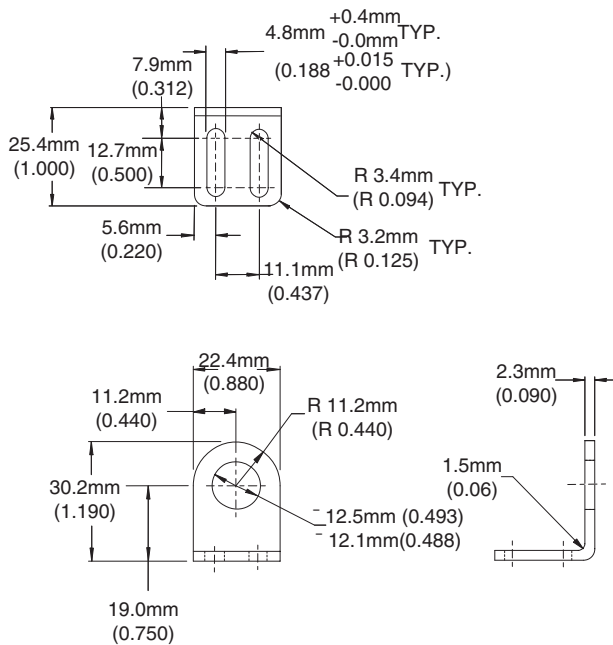

### AC236

Stainless and polyamide conveyor-rail clamp/  
bracket set (for 12 mm barrel sensor)

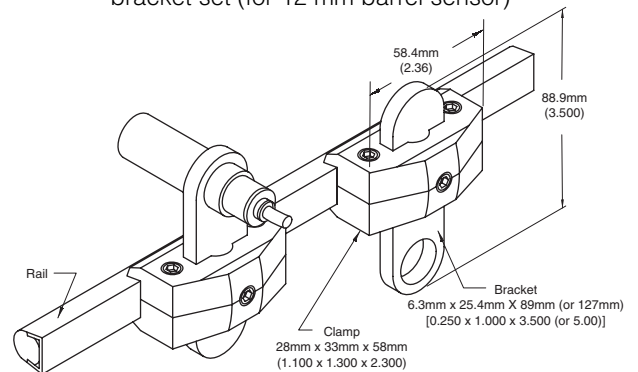

### AC237

Straight, stainless, mounting bracket  
(for 12 mm barrel sensors)

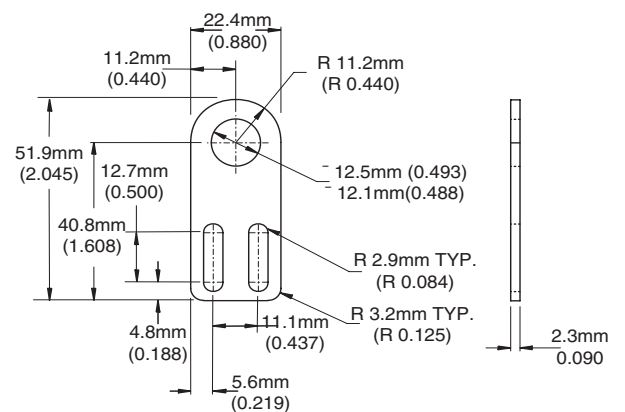

SUPERPROX® SM302  
SERIES

## General Specifications

### Sensing [ $T_A = 20^\circ\text{C}$ ( $68^\circ\text{F}$ )]

#### Sensing Range:

31.7 mm (1.25") to 102 mm (4.0")  
(large flat objects)

Highest sensitivity over the range 38.1 mm  
(1.5") to 102 mm (4.0")

#### Sonic Frequency: 500 kHz

#### Minimum-size Detection:

2.5 mm (0.098") diameter rod or 1.0 mm  
(0.039") wide flat bar at a distance of 38 mm  
(1.5")

Note: Smaller object may not be detected at  
closer distances

#### Maximum Angular Deviation:

$\pm 8^\circ$  on a 100 mm x 100 mm (4" x 4") flat  
target at a distance of 89 mm (3.5")  
(4" range flat-profile)

#### Sonic Cone Profile:

see beam plot on page 4-2

#### Limit Position Accuracy:

$\pm 1.6$  mm (0.062") max.

#### Repeatability:

$\pm 0.7$  mm (0.027") or better

### Power Requirements

#### Supply Voltage:

12VDC to 24VDC  $\pm 10\%$ , regulated supply

#### Current Consumption:

25 mA max. (excluding load)

#### Power Consumption:

0.5 W max. (excluding load)

### Output

#### Sinking Output (NPN):

Maximum on-state voltage: 0.75 V @ 100 mA

Maximum load current: 100 mA

Maximum applied voltage: 30 VDC

#### Sourcing Output (PNP):

Maximum on-state voltage drop: 1.10 V @

100mA

Maximum load current: 100mA

Output voltage:  $V_{\text{Supply}} - 1.10$  V @ 100mA

### Response Time

3.0 ms on/ 3.0 ms off (2" range)

4.0 ms on/ 4.0 ms off (4" range)

### Indicators

Amber LED: Illuminated if power applied and  
no object detected

Orange LED: Illuminated if object is detected  
within the window, regardless of output polarity  
(N.O./N.C.) style.

Note: Amber and orange LEDs are never  
illuminated simultaneously

### Connections

#### Cable Style Models:

28 AWG, foil shield, lead-free, PVC jacket  
4-conductor, 3M (10') long

#### Connector Style Models:

8 mm, circular 4-pole, male  
Flat-profile pigtail 152 mm (6.0") long  
micro-connector

### Protection

Power Supply: Current-limited over-voltage, ESD,  
reverse polarity

Outputs: Current-limited over-voltage, ESD,  
reverse polarity, over-current

### Environmental

#### Operating Temperature Range:

$-30^\circ$  to  $70^\circ\text{C}$  ( $-22^\circ$  to  $152^\circ\text{F}$ ) @ 12V supply

$-30^\circ$  to  $65^\circ\text{C}$  ( $-22^\circ$  to  $149^\circ\text{F}$ ) @ 24V supply

#### Storage Temperature Range:

$-40^\circ$  to  $100^\circ\text{C}$  ( $-40^\circ$  to  $212^\circ\text{F}$ )

#### Operating Humidity: 100%

Protection Ratings: NEMA 4X, IP67

Chemical Resistance: Resists most acids and  
bases, including most food products.

### Agency Approvals

CE Mark: CE conformity is declared to:

EN60947:1998 (proximity sensors)

EN61010-1 (general safety)

EMC:

FCC 47 CFR Part 15 Class A (USA)

EN5022:1994 / A2:1997 Class A ITE (EU)

VCCI Class A ITE (Japan)

AS/NZS 3548:1995 / CISPR 22 Class A ITE

(Australia)

*Declaration of Conformity available upon request*

### Construction

#### Dimensions:

##### Barrel

Cable Model: 12 mm (0.472") dia. x 1 mm-6g

threaded housing x 53.3 mm (2.10") long

Connector Model: 12 mm (0.472") dia. x 1

mm-6g threaded housing x 55 mm (2.17")

long;

Overall length including right angle, connector/  
cable assembly: 67.6 mm (2.66")

Flat-profile

##### Flat-profile

Cable/Connector Model: 33.0 mm (1.3") H x

7.62 mm (0.3") W x 19.05 mm (0.75") L

#### Housing:

Shock and vibration resistant

Case: ULTEM® plastic (FDA Approved)

Transducer Face: Epoxy

Sensor Cable: Lead-free, PVC jacketed, black

LED light ring: Polycarbonate

\* ULTEM® is a registered trademark of The General Electric  
Co.

## Accessories

**Model AC130**, Straight, M12 micro, 4-conductor,  
connector/cable assembly, 5 m (16'), for micro-  
connector sensors

**Model AC132**, Right-angle, M12 micro, 4-  
conductor, connector/cable assembly, 5 m (16'),  
for flat-profile connector-style sensors

**Model AC134**, Right-angle, M8 pico, 4-conductor,  
connector/cable assembly, 5m (16') for barrel and  
flat-profile connector-style prox sensors

**Model AC135**, Straight, M8 pico, 4-conductor,  
connector/cable assembly, 5m (16') for barrel and  
flat-profile connector-style prox sensors

**Model AC137**, Nano-to-micro pigtail adapter cable  
for barrel connector-style prox sensors

**Model AC138**, Nano-to-micro pigtail adapter cable,  
output pins reversed for barrel connector-style  
prox sensors

**Model AC141**, Right-angle, M8 pico, 3-conductor,  
connector/cable assembly, 5 m (16') for flat-profile  
connector-style sensors

**Model AC142**, Straight, M8 pico, 3-conductor,  
connector/cable assembly, 5 m (16') for flat-profile  
connector-style sensors

**Model AC235**, Right-angle, stainless, mounting  
bracket for barrel connector-style prox sensors

**Model AC236**, Stainless and polyamide conveyer-  
rail clamp/bracket set for barrel connector-style  
prox sensors

**Model AC237**, Straight, stainless, mounting bracket  
for barrel connector-style prox sensors

**Model AC242**, 18 mm to 12 mm hex mounting  
adapter

**Model AC243**, 30 mm to 12 mm hex mounting  
adapter

See page 7-1 for accessory photos.



# Selection Chart

## SM302 Series Dual-Level

Model No.	Power Version 12/24 VDC	Conn. Style		Sensing	Materials					Notes		
		Cable	Connector		Range	Window	Transducer	Housing			Functionality	
							Epoxy	12 mm ULTEM®	Flat-profile		Pump-in	Pump-out
SM302A-212-00	■	■		50.8 mm (2.0")	19.05 mm (0.75")	■	■			■		
SM302A-212-10	■	■		50.8 mm (2.0")	19.05 mm (0.75")	■	■		■			
SM302A-212-00FP	■	■		50.8 mm (2.0")	19.05 mm (0.75")	■	■	■		■		
SM302A-316-00	■	■		72.6 mm (3.0")	25.4 mm (1.0")	■	■			■		
SM302A-316-10	■	■		72.6 mm (3.0")	25.4 mm (1.0")	■	■		■			
SM302A-316-00FP	■	■		72.6 mm (3.0")	25.4 mm (1.0")	■	■	■		■		
SM302A-416-00	■	■		101.6 mm (4.0")	25.4 mm (1.0")	■	■			■		
SM302A-416-10	■	■		101.6 mm (4.0")	25.4 mm (1.0")	■	■		■			
SM302A-416-00FP	■	■		101.6 mm (4.0")	25.4 mm (1.0")	■	■	■		■		
SM302A-432-00	■	■		101.6 mm (4.0")	50.8 mm (2.0")	■	■			■		
SM302A-432-10	■	■		101.6 mm (4.0")	50.8 mm (2.0")	■	■		■			
SM302A-432-00FP	■	■		101.6 mm (4.0")	50.8 mm (2.0")	■	■	■		■		
SM352A-212-00	■		■	50.8 mm (2.0")	19.05 mm (0.75")	■	■			■		
SM352A-212-10	■		■	50.8 mm (2.0")	19.05 mm (0.75")	■	■		■			
SM352A-212-00FP	■		■	50.8 mm (2.0")	19.05 mm (0.75")	■	■	■		■		
SM352A-316-00	■		■	72.6 mm (3.0")	25.4 mm (1.0")	■	■			■		
SM352A-316-10	■		■	72.6 mm (3.0")	25.4 mm (1.0")	■	■		■			
SM352A-316-00FP	■		■	72.6 mm (3.0")	25.4 mm (1.0")	■	■	■		■		
SM352A-416-00	■		■	101.6 mm (4.0")	25.4 mm (1.0")	■	■			■		
SM352A-416-10	■		■	101.6 mm (4.0")	25.4 mm (1.0")	■	■		■			
SM352A-416-00FP	■		■	101.6 mm (4.0")	25.4 mm (1.0")	■	■	■		■	4-pin "PICO" (8 mm) connector	
SM352A-432-00	■		■	101.6 mm (4.0")	50.8 mm (2.0")	■	■			■		
SM352A-432-10	■		■	101.6 mm (4.0")	50.8 mm (2.0")	■	■		■			
SM352A-432-00FP	■		■	101.6 mm (4.0")	50.8 mm (2.0")	■	■	■		■		

All possible sensor configurations are not listed here.  
Range and window examples shown available in all cable or connector styles.

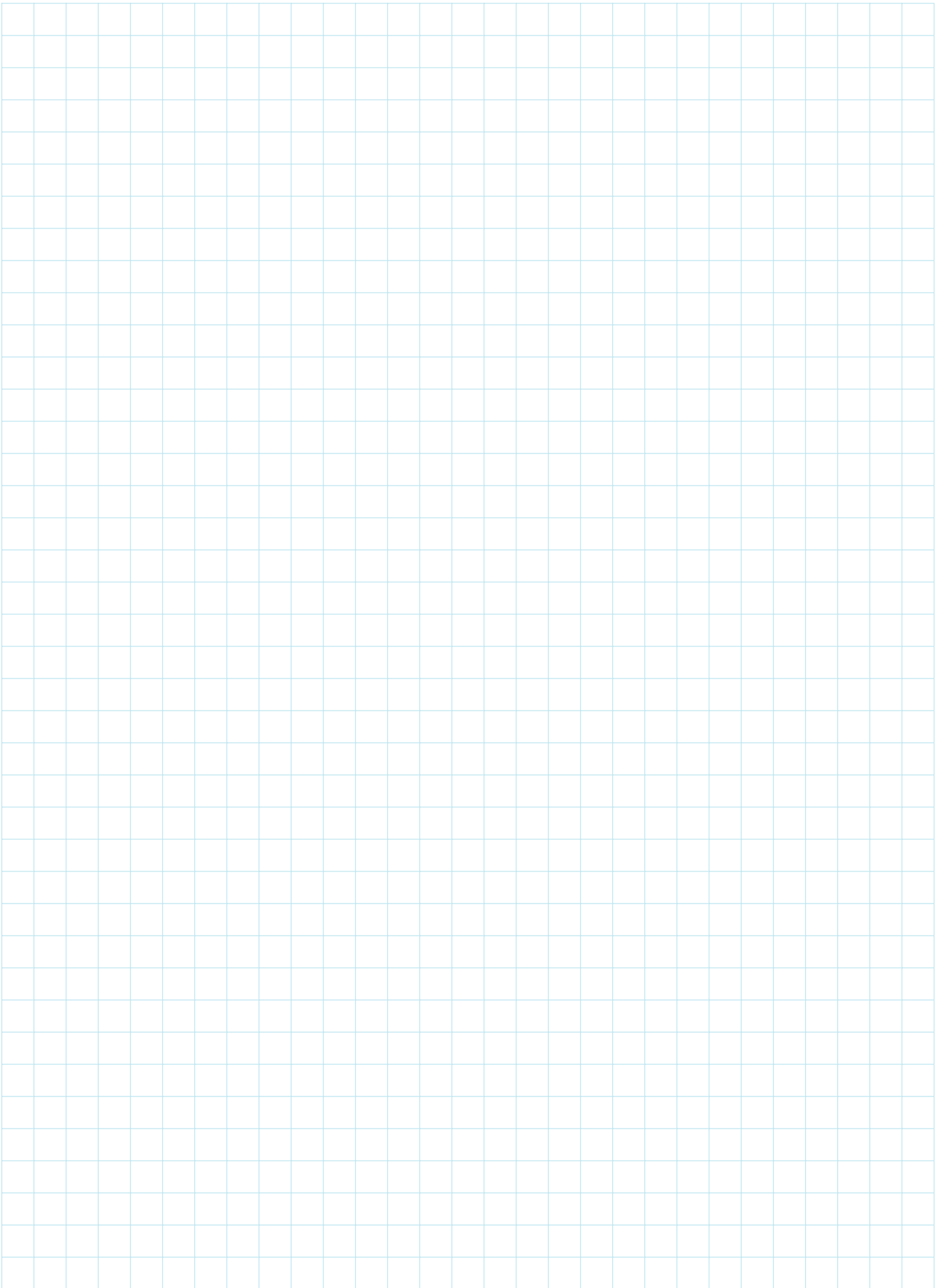

# SUPERPROX® 500 Series Introduction

## **A selection of SUPERPROX® ultrasonic sensors for your tough sensing applications.**

Hyde Park has combined piezoelectric and microprocessor technology to become the world's leading manufacturer of ultrasonic "smart" proximity sensors. For more than 40 years, Hyde Park sensor products have provided reliable, cost-effective answers for the most difficult, noncontact sensing applications.

The SUPERPROX® 500 series of ultrasonic smart proximity sensors represents a broad range of sensing solutions in place today where other sensing technologies have not met standards for reliability and productivity. The difficulties associated with clear containers, metal parts, irregular shapes and sizes, harsh environments, high-speed runs, cleaning solutions, and frequent washdowns are simply no match for this reliable sensor line. The sensors are impervious to changing light condition, colors, dust, caustic chemicals, and other hostile environments. Using sound energy as the sensing medium, these sensors can be counted on day in and day out in detecting objects either transparent or opaque, liquid or solid, and as small as 6 mm (1/4"), regardless of color or shape. In some cases, features as small as 0.076 mm (0.003") can be detected.

## **"Smart" SUPERPROX® 500 Proximity Sensors for Top Performance**

The SUPERPROX® 500 series sensors are self-contained, pulse-echo devices that both transmit and receive sonic energy within sensing ranges up to 2 meters (79"). The sensors use the latest ultrasonic technology along with a discriminating microprocessor and push-button setup program to ensure the

ultimate in sensing reliability. This state-of-the-art sensing concept enables the SUPERPROX® 500 series sensors to ignore all surrounding interference and detect only the designated object. When the object to be detected is at or within the user-set "window" limits, either a discrete output switches or an analog output changes proportionally with respect to those limits, depending on the sensor model in operation.

### **Easy to Set Up**

The SUPERPROX® 500 series sensors are very easy to set up and operate. The sensor outputs, whether discrete or analog, are compatible with most logic control systems and programmable controllers. One of the unique benefits of the sensor series is the ease in which it can be set up for an application by the user. Inside a sealed control compartment at the rear of the sensor are setup switches, push-buttons, and potentiometers, the combination of which is determined by the specific model type. Access to the sealed compartment is gained by removing two screws in the cover. A short plastic tether prevents separation of the cover from the sensor.



**SM500 Control Compartment with Sealed Door**

### **How does it work?**

During setup and operation, the SUPERPROX® 500 series sensors continually and accurately measure the elapsed time of every pulse echo reception between each pulse transmission. The transmitted pulse begins a time clock to determine

## *Ultrasonic Sensors*



### **SUPERPROX® Model SM500 Series**

*Proximity sensing with no delay*

### **SUPERPROX® Model SM502 Series**

*Dual-level sensing with on & off latch control*

### **SUPERPROX® Model SM503 Series**

*Proximity sensing with on & off delay*

### **SUPERPROX® Model SM504 Series**

*Synchronized/gate-controlled proximity sensing*

### **SUPERPROX® Model SM505 Series**

*Rate and stopped motion proximity sensing with on delay*

### **SUPERPROX® Model SM506 Series**

*Continuous level or distance sensing with analog output*

**SUPERPROX® SM500  
SERIES INTRO**

the elapsed time for the received pulse echoes. Given the elapsed time, the sensor software calculates the distance traveled out to the object and back to the sensor, using the formula,  $D = TVs/2$ , where  $D$  = distance from the sensor to the object;  $T$  = elapsed time between the pulse transmission and its echo receptions;  $Vs$  = velocity of sound, approximately 1100 feet per second.

When setting the sensing window limits, using the "LIMITS" push-button in the control compartment, a target or object is placed in front of the sensor successively at the set points representing the desired inner ( $D_{wi}$ ) and outer

( $D_{wo}$ ) limits shown in Figure 1. When the LIMITS push-button is pressed at each set point, the respective distances ( $D_{wi}$  and  $D_{wo}$ ) from the sensor are automatically calculated and stored in the sensor memory to represent the sensing window limits.

During operation, the calculated distance ( $D$ ) between the sensor and the object is compared to the distances between the sensor and the set window limits. If " $D$ " is at or within the window limits, an output change takes place and remains un-

changed until the echo either does not return or it returns from outside the window limits.

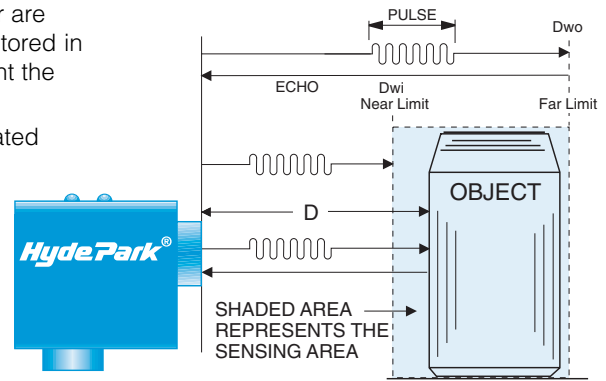

**To meet a multitude of application needs, the SUPERPROX® 500 series sensors offer a variety of models and sensing techniques.**

**Proximity sensing with no delay**

**Model SM500 series**

Typical Application:

**Object detection**



See Model SM500 series product data on Page 4-23.

**Dual-level sensing with on & off latch control**

**Model SM502 series**

Typical Applications:

**Level monitoring and control as in starting and stopping a pump or opening and closing a valve**



See Model SM502 series product data on Page 4-31.

**Proximity sensing with on & off delay**

**Model SM503 series**

Typical Application:

**Jam & Gap detection**



See Model SM503 series product data on Page 4-41.

**Synchronized/gate-controlled proximity sensing**

**Model SM504 series**

Typical Applications:

**Full or empty case inspecting, on-demand-controlled sensing or inspecting, in-case-container counting, automation control sensing, object-in-area sensing, down-container sensing, differential-height inspecting**



See Model SM504 series product data on Page 4-47.

The SUPERPROX 500 sensor series is CE certified with the AC-power models qualified to carry the EIL safety label.

**Rate & stopped motion proximity sensing with on delay**

**Model SM505 series**

Typical Applications:

**Container backup detection on either a mass conveyor or a single file conveyor**



See Model SM505 series product data on Page 4-53.

**Continuous level or distance sensing with analog output**

**Model SM506 series**

Typical Applications:

**Level/distance sensing applications ranging from complex closed-loop control to simple status (e.g., distance measuring monitoring functions)**



See Model SM506 series product data on Page 4-61.

## Beam Plots

The following plots, developed from data collected at 20°C, zero air flow, define the boundaries and shape of the sonic beam for various Hyde Park ultrasonic sensor series.

The boundaries were established using a 10 cm x 10 cm (3.94" x 3.94") "target" positioned parallel to the sensor face. The plot for each sensor series is valid for targets equal to or larger than 10 cm x 10 cm. Beam boundaries are determined by moving the large flat target into the beam while the plane of the target is held perpendicular to the beam axis.

In each series, the plot extends from the end of the "deadband" on the left to the end of the sensing range on the right. The sensor is illustrated in the middle left margin.

These and other plots are available from Hyde Park upon request.

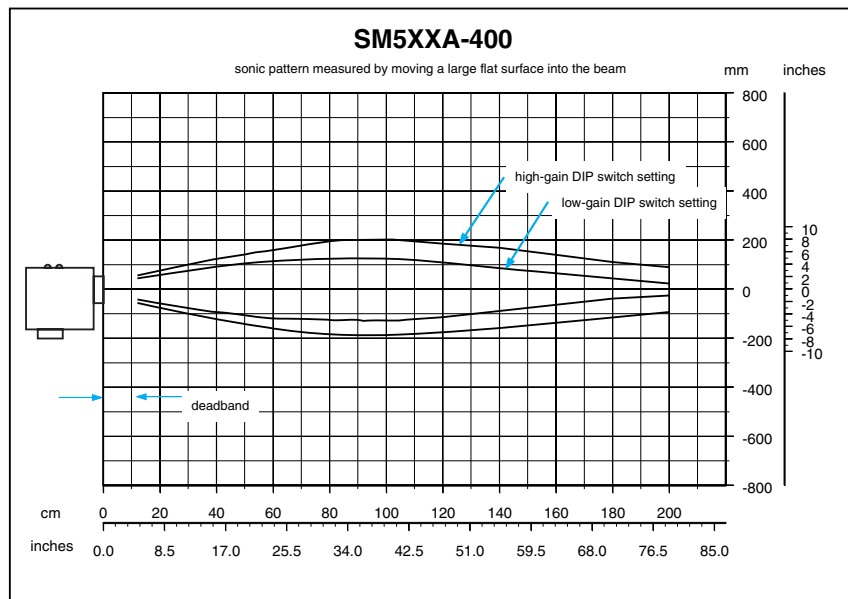
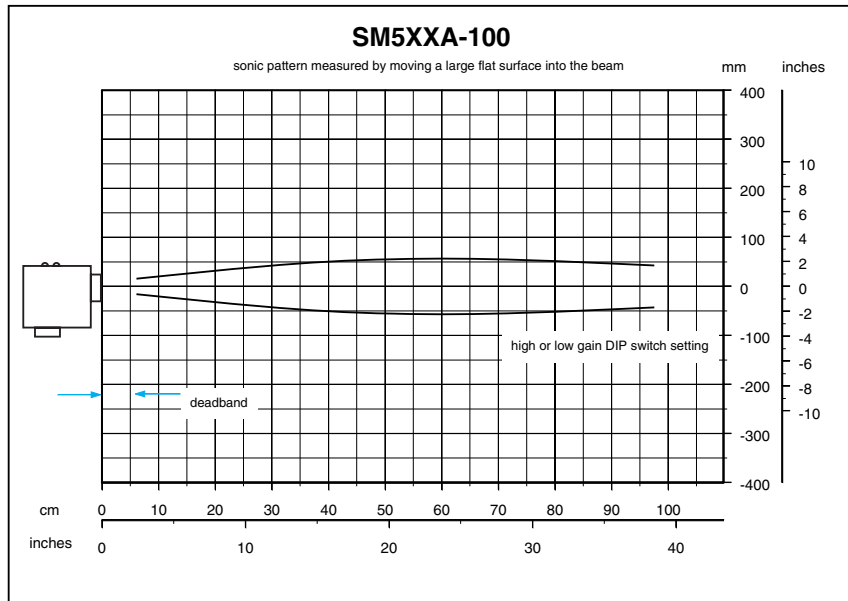
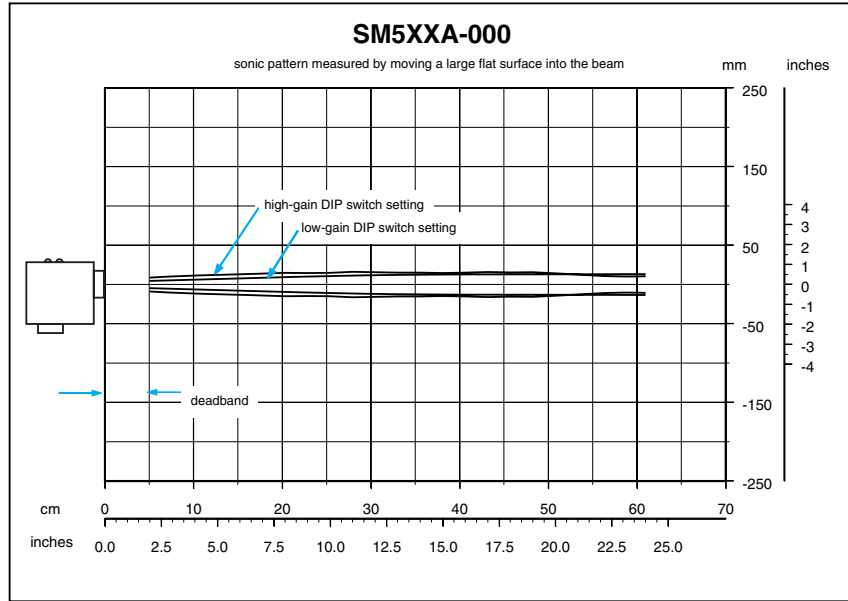

**SUPERPROX® SM500  
SERIES INTRO**

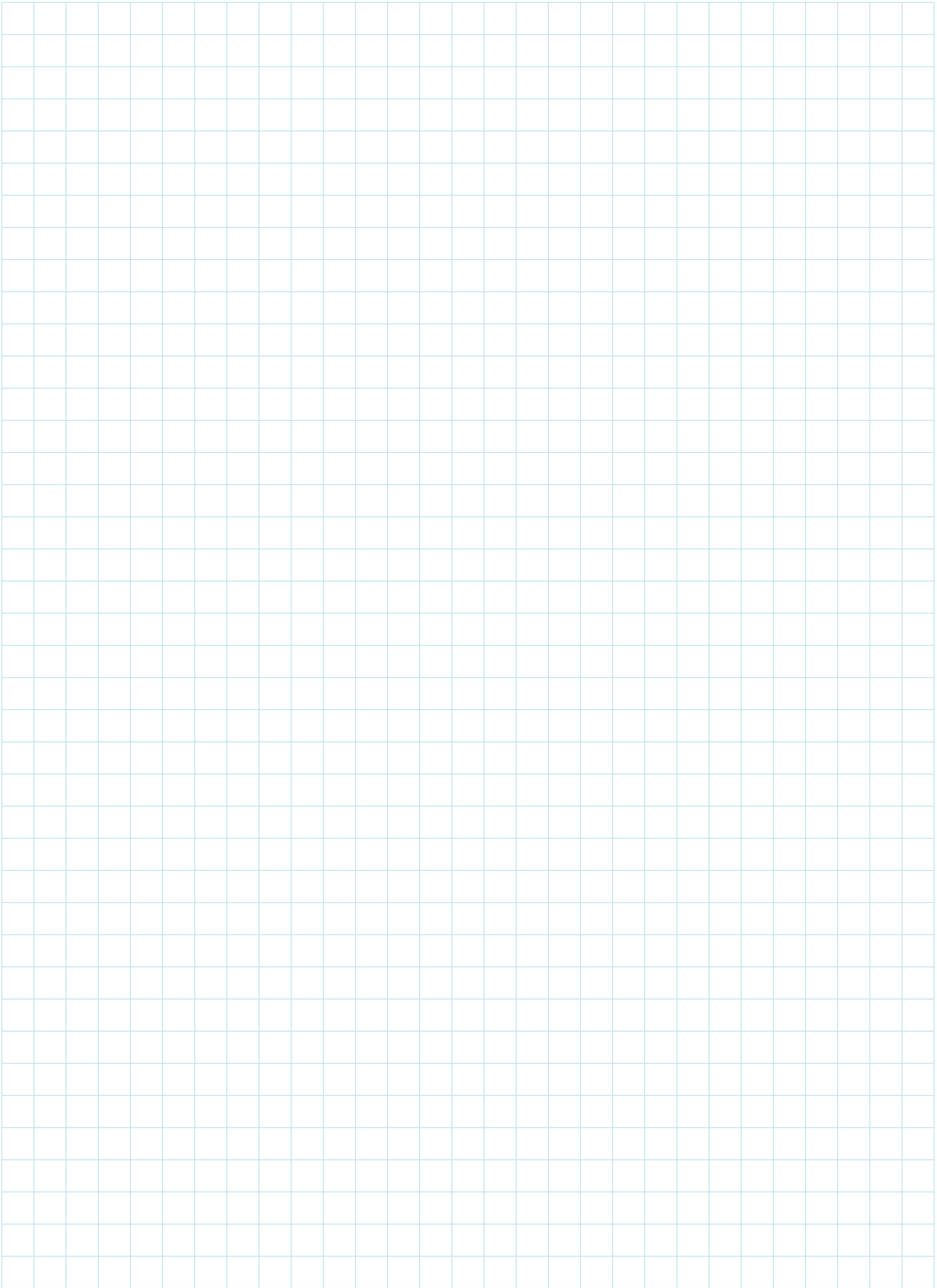

## Model SM500 Series

### SUPERPROX® Ultrasonic Proximity Sensors

*No delay  
sensing*

- *Easy push-button setup for the specific application*
- *Onboard microprocessor for reliability and repeatability*
- *Noncontact sensing range up to 2 m (79")*
- *Epoxy sealed in tough ULTEM® housing*
- *Virtually impervious to the harshest environments*
- *CE certified*
- *AC-powered models ETL listed*

units per minute.

AC and DC models are available with a sensing range of 51 mm to 1 m (2 to 39") and 120 mm to 2 m (4.7 to 79"), respectively. These sensors carry the CE Mark and the AC-powered models are also ETL approved. The sensor housing meets NEMA 4X and IP67 industry standards. A Dairy 3A compliant housing is available as an option.



This basic model series in the SUPERPROX® family of ultrasonic, noncontact sensors offers reliable object detection where simple on/off control of the outputs are required. These "smart" sensors use the latest

ultrasonic technology to ensure the ultimate in sensing reliability through a discriminating microprocessor, push-button setup program.

It is this discrete sensing program that enables the SUPERPROX® sensors to detect only those objects that are within a set "window" and ignore all others. A simple push-button is used to set a window as small as 13 mm (1/2").

Used throughout plants in all industries, the SUPERPROX® Model SM500 (cable style) and Model SM550 (connector style) series of noncontact sensors control various operations. Typical applications include loop control and end of roll detection, web breaks, and parts presence. The sensors are also used to detect containers and produce outputs for no container/no fill and no container/no cap control. In conveying operations, with objects in a captured state, these sensors are used for counting at speeds up to 2000

## Control Compartment

A unique feature available to the user of these sensors is the ability to quickly set up each sensor for a specific application. The sensor is configured through either three or four slide switches, depending on the model, and a push-button (See Figure 1) located

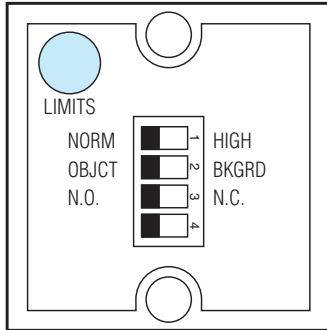

Figure 1

inside a water-tight control compartment on the sensor. To access the controls, remove the small square cover on the back of the sensor. Simply loosen the two flathead cover screws and insert a small-blade screwdriver in either the top or bottom slot to remove the cover. A short plastic tether prevents separation of the cover from the sensor. NOTE: The switch settings may require changing for the intended application.

## Sensor Configuration

### Switches

**Switch 1** configures the sensor to operate in either a normal or high sensitivity mode. Place this switch in the NORM position for sensing liquid or solid materials. Place the switch in the HIGH position for sensing soft or porous materials that will absorb some of the ultrasonic energy.

**Switch 2** configures the sensor to operate in either an object or background sensing mode. Place this switch in the OBJCT position to perform a sensing function for receiving the reflected ultrasonic energy directly off an object. Place this switch in the BKGRD position to perform a break-beam sensing function for receiving the reflected ultrasonic energy directly off a fixed background target.

**Switch 3** selects the operating mode for the sensor output to be either normally open (N.O.) or normally closed (N.C.).

**Switch 4** (Not used)

## Model Reference Guide – SM500 Series

Use the guide below to ensure the correct model number is specified for the application. Please note that not all sensor model combinations are available.

### EXAMPLE MODEL:

	<b>SM5 00 A - 1 00 - FS R 2</b>
<b>SUPERPROX® Product Series</b>	_____
<b>Power/Connection Type</b>	_____
0...12 to 24 VDC / cable style	
2...100 to 240 VAC / cable style	
5...12 to 24 VDC / connector style	
7...100 to 240 VAC / connector style	
<b>Sensing Function</b>	_____
0...Proximity - no on/off delay	
<b>Design Level</b>	_____
A...Applies to all DC-powered models	
B...Applies to all AC-powered models	
<b>Sensing Range</b>	_____
0...51 to 635 mm (2 to 25")	
1...51 to 1 m (2 to 39")	
4...120 mm to 2 m (4.7 to 79")	
<b>Functionality</b>	_____
00...Standard proximity	
44...Default window: ±0.10"	
75...High gain, default window: +0.5"/-0.25"	
80...Delay: divide by 10 output	
91...Default window: ±0.05" hysteresis: 0.02, ±0.0625" automatic setup window	
<b>Special Features</b>	_____
... No letter indicates standard sensor with no special features	
FS... Fluorosilicone transducer face	
AA... Remote limit setup (Available on cable models only.)	
AB... RS232, 4-digit/2-decimal place output	
AD... Limits push-button disabled	
AE... RS232, 5-digit/3-decimal place output	
AF... No LEDs	
<b>Housing Types</b>	_____
... No letter indicates standard ULTEM® plastic housing	
N...NORYL® Dairy 3A gray plastic housing	
<b>Remote Type</b>	_____
... No letter indicates standard housing	
R...Right-angle sensing head with armor cable	
S...Straight sensing head with armor cable	
<b>Remote Cable Length</b>	_____
... No letter indicates standard housing	
1...254 mm (10")	} Armored (standard) or PVC cable (specify P after number)
2...508 mm (20")	
3...762 mm (30")	
4...1016 mm (40")	
5P...1270 mm (50")	} Available in PVC cable only
6P...1524 mm (60")	

\* ULTEM® and NORYL® are registered trademarks of The General Electric Company.



## Sensor Limits Setup Push-button

First, during installation, make sure the sensor face is as parallel as possible to the surface of the material being detected.

To set the limits, simply place an object at the desired distance from the sensor for one limit and press the LIMITS push-button once. This sets the first limit and switches the sensor output to an inactive state during the limit setup. While the LIMITS push-button is depressed, the multicolored LED, located on top of the sensor, is amber. Upon release of the push-button, the LED flashes amber indicating that the second limit needs to be set within 30 seconds. Place an object at the desired position for the second limit and press the LIMITS push-button once. Again, while the push-button is depressed, the LED is amber. Upon release of the push-button, the LED flashes amber momentarily and then turns green to indicate acceptance of both limits. If 30 seconds elapse before the second limit is set, the limits revert back to the previous settings.

At the same time, the sensor output switches from the inactive to the active state, placing the sensor into the operational mode, ready to use. When power is off or interrupted, the limits are retained in a non-volatile memory.

If in setting either limit the echo from the object is too weak or distorted, the LED flashes RED for 10 seconds (or until the button is pressed again) indicating the limit setting was not accepted by the sensor. Attempt to set both limits again, being careful to keep the object surface parallel to the face of the sensor.

Minimum allowed distance between any two setup limits is 13 mm (1/2"). The multicolored LED flashes RED after the press and release of the LIMITS push-button for the second limit setting if the distance between the limit settings is less than 13 mm. The multicolored LED continues flashing RED either until the LIMITS push-button is pressed and released once for the first limit setting or until 10 seconds have elapsed. Pressing and releasing the LIMITS push-button once reinitiates the limit setup sequence. If 30 seconds elapse before the LIMITS push-button is pressed and released for the second limit setup, the limits revert back to the previous settings.

A special feature provides an automatic 13 mm (1/2") window limits setup function. Simply place an object within

the sensing range of the sensor and press the LIMITS push-button twice in succession without moving the object. A limit is set on a line 1/4" in front and back of the object surface nearest the sensor.

## Multicolored LED Indicator During Limit Setup

Prior to pressing LIMITS push-button

- Off - Sensing no object or object is outside the sensing range
- Red - Sensing an object outside the set limits
- Green - Sensing an object inside the set limits

LIMITS push-button depressed for first time

- Amber - Sensing a good object surface condition
- Red - Sensing no object or a poor object surface condition

LIMITS push-button released for first time

- Flashing Amber - First limit accepted, waiting for second limit
- Flashing Red - First limit not accepted; retry setting limit

LIMITS push-button depressed for second time

- Amber - Sensing a good object surface condition
- Red - Sensing no object or a poor object surface condition

LIMITS push-button released for second time

- Green, Red, or Amber - Second limit accepted
- Flashing Red - Second limit not accepted; retry setting both limits

## Multicolored LED Indicator in Operational Mode

- Off - Sensing no object or object is outside the sensing range
- Red - Sensing an object outside the set limits
- Green - Sensing an object inside the set limits

## Red LED Indicator in Operational Mode

The red LED serves as a visual indicator for the sensor output. The LED is illuminated when the output is in an active (ON) state.

## Electrical Wiring

Sensor wires must be run in conduit free of any AC power or control wires.

### Sensor Wire Colors

#### DC Models

	Cable Style	Connector Style
+12 to 24 VDC	RED	BROWN
NPN/Sinking Output	WHITE	BLACK
PNP/Sourcing Output	GREEN	WHITE
Common	BLACK	BLUE

#### AC Models\*

100 to 240 VAC	BROWN	BROWN
Switch Line Side	BLACK	BLACK
Switch Load Side	WHITE	WHITE
Neutral	RED	BLUE

#### \*WARNING

All cables are not alike. Verify that connector pin outs and cable conductor colors match up with the wiring illustrations shown in the operating instructions.

### View of Plug on Connector Style Sensor

#### DC Power Models

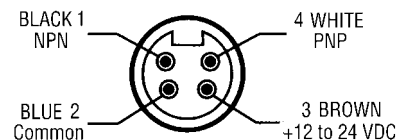

#### AC Power Models

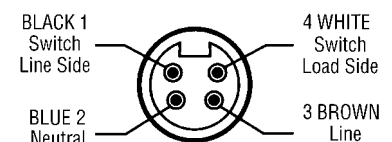

## Outputs

### DC Cable Models

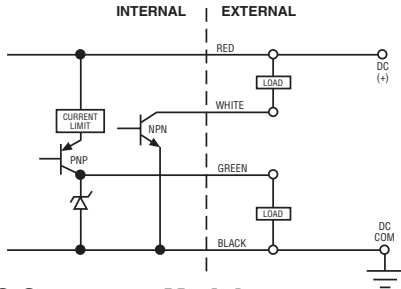

### DC Connector Models

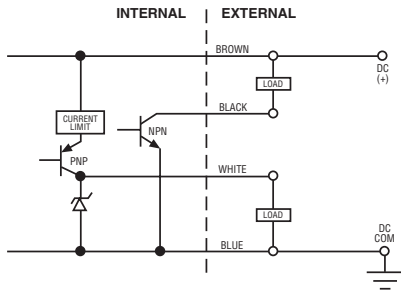

### AC Cable Models

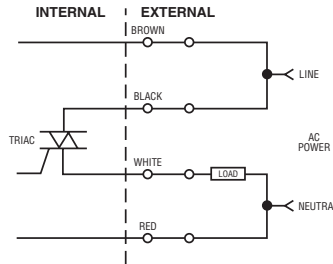

### AC Connector Models

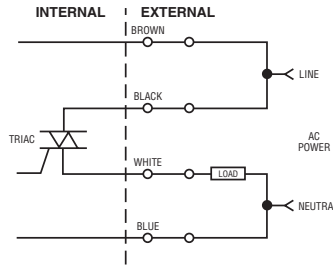

## Sensor Wire Connections

### DC Cable Models

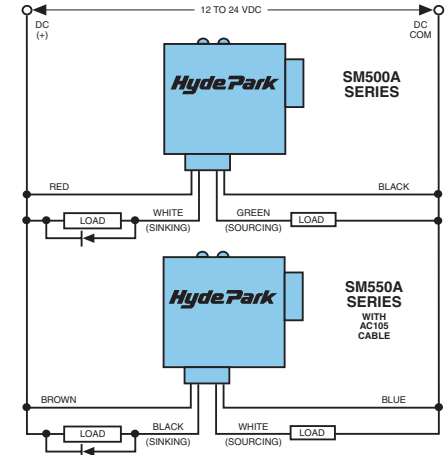

### AC Cable Models

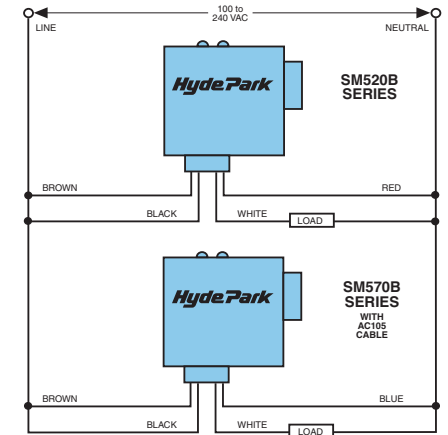

## Dimensions

### Cable Model

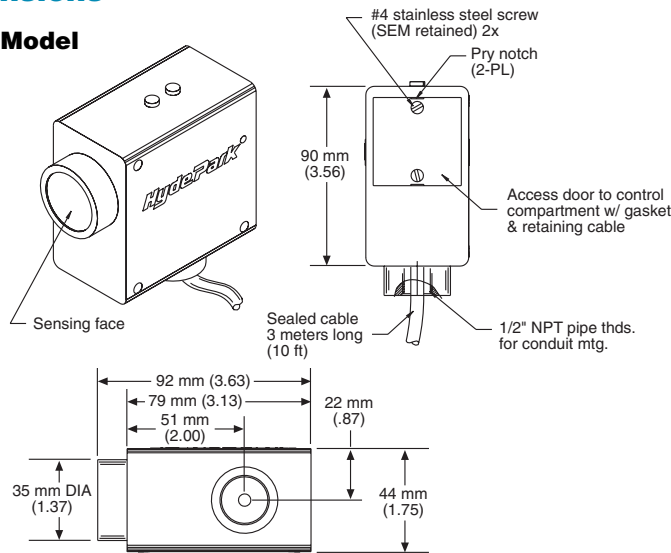

### Connector Model

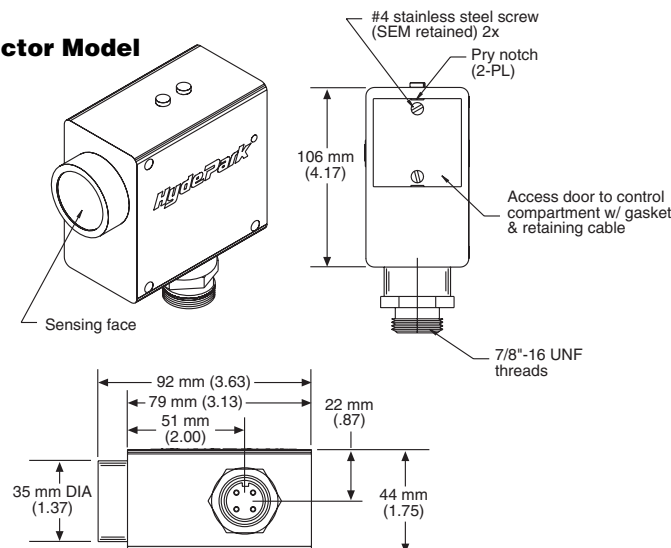

### Remote Sensing Models

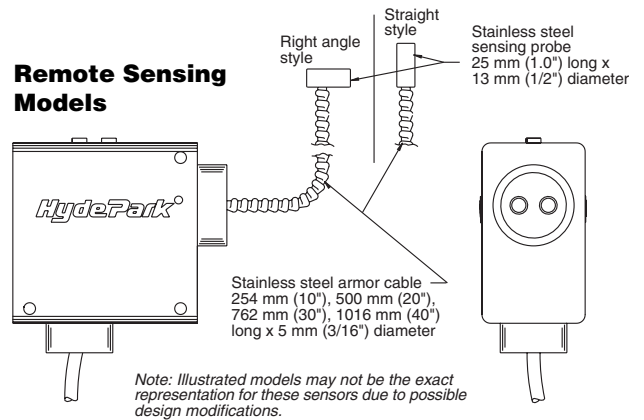

## Mounting Accessories

### AC230

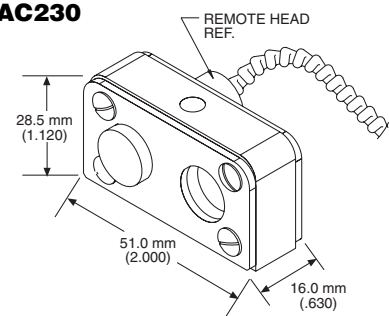

## Mounting Accessories

### AC213

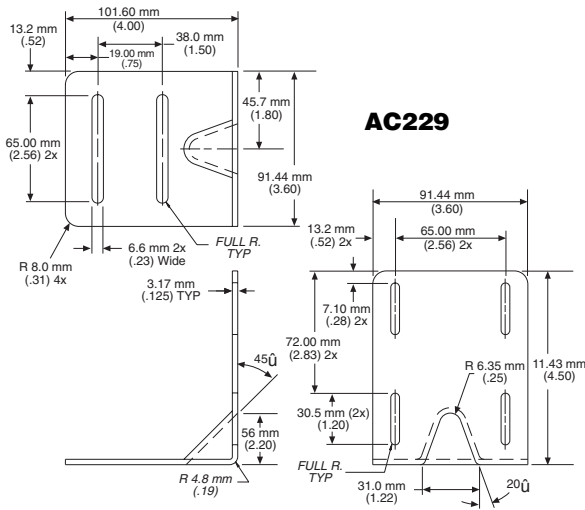
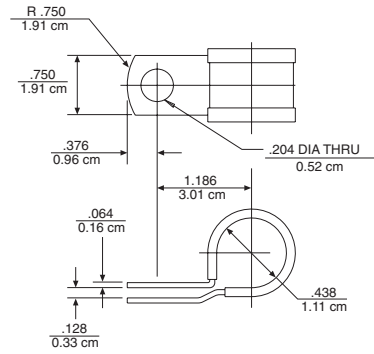

### AC222

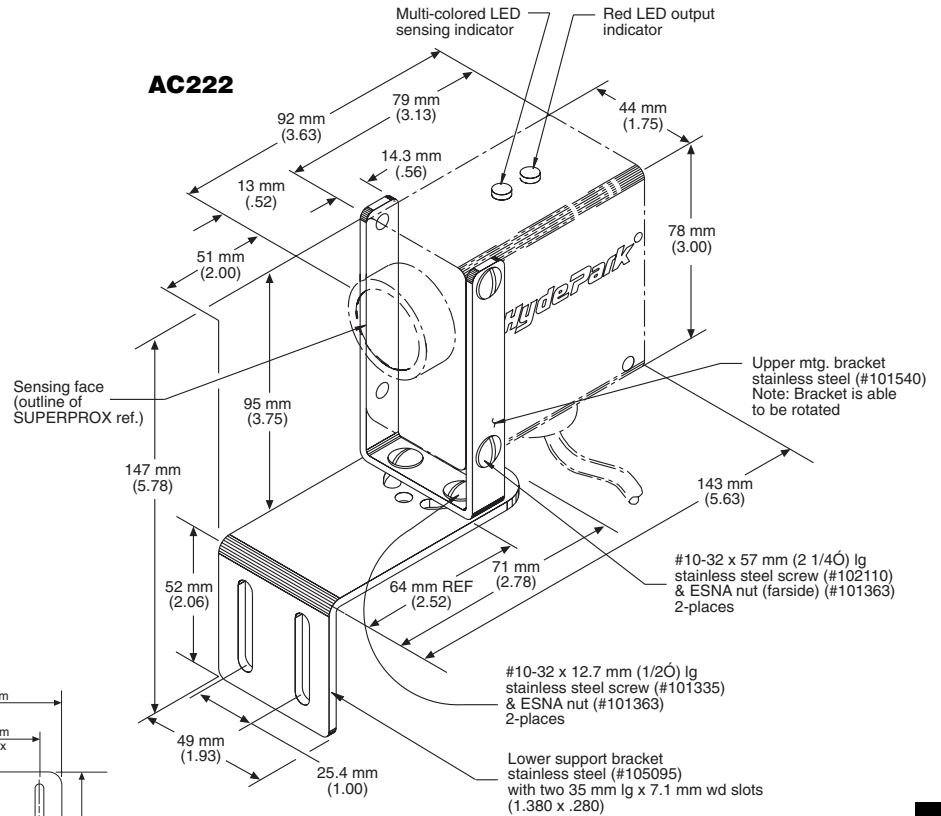

### Response Time

"On" 10 ms,  
"Off" 10 ms to "On" 30 ms,  
"Off" 30 ms, depending upon model

### Indicators

Multicolored (Amber, Red,

Green) LED:

Indicates limits setup and operational modes  
Red LED: Visual indicator for sensor output;  
illuminated when output is in an active (on) state.

### Connections

Cable Style Models:

DC: 24 AWG, PVC jacket, 4-conductor,  
3 meters (10') long, standard

AC: 20 AWG, PVC jacket,  
4-conductor, 3 meters (10') long, standard

Connector Style Models:

DC: 4-pin "mini" style

AC: 4-pin "mini" style

### Protection

Power Supply: current-limited over-voltage, ESD,  
reverse polarity, fuse on AC model

Outputs: current-limited over voltage, ESD,  
over-current, fused TRIAC on AC model

### Environmental

Operating Temperature Range:

0° to 50° C (32° to 122° F)

Storage Temperature Range: -40° to 100° C

(-40° to 212° F)

Operating Humidity: 100%

Protection Ratings: NEMA 4X, IP67

Chemical Resistance: Resists most acids and  
bases, including most food products.

Fluorosilicone transducer face is available to  
provide resistance to aromatic and petroleum-  
based hydrocarbons.

### Agency Approvals

CE Mark: CE conformity is declared to:

EN61010-1: 1990 including amend. No.1:  
1992 EN55011 Group 1 Class A, EN50082-1.  
*Declaration of conformity available upon re-  
quest.*

AC Models SM520/570 carry the ETL safety  
label.

### Construction

Dimensions (overall)

92 mm (3.625") L x 44 mm (1.75") W x 91 mm  
(3.58") H

Housing:

Case: ULTEM® (FDA approved)

Optional: NORYL® (USDA-Dairy 3A  
Sanitary Standards compliant)

Transducer Face: Silicone rubber (FDA  
approved)

Optional: Fluorosilicone rubber

Sensor Cable: PVC jacket

LED: Polycarbonate

\* ULTEM® and NORYL® are registered trademarks of The  
General Electric Co.

## Accessories

**Model AC105**, Straight, 7/8-16 mini, 4-conductor,  
mating connector cable, 4 m (12'), for connector-  
style sensors

**Model AC105-50**, Straight, 7/8-16 mini, 4-  
conductor, mating connector cable, 15 m (50'), for  
connector-style sensors

**Model AC213**, Stainless and Teflon, remote sensing  
probe mounting bracket

**Model AC222**, Standard, stainless mounting  
bracket assembly, slotted for vertical adjustment

**Model AC229**, Stainless, plate-style, right-angle,  
mounting bracket, with base slotted for forward/  
reverse adjustment and side slotted for sensor  
adjustment

**Model AC230**, Three-piece, stainless, mounting  
bracket assembly with O-ring mount for sensor  
models with remote heads.

See page 7-1 for accessory photos.

## General Specifications

### Sensing

Ranges:

51 to 1 m (2 to 39')

120 mm to 2 m (4.7 to 79' - DC Model only)

Sonic Frequency: 200 kHz

### Power Requirements

DC Models:

12 to 24 VDC ± 10% @ 80 mA, 2 W max.,  
excluding output load (regulated supply)

AC Models:

100 to 240 VAC, 50/60 Hz, @ 30 mA, 7.5 VA  
max., excluding load

### Outputs

DC Models:

NPN Sinking: Switch selectable N.O./N.C.

Sinking on-state voltage drop:

Maximum 0.25 volts @ 60 mA

Sinking load current:

Maximum 100 mA

Sinking output voltage:

Maximum applied 30 VDC

PNP Sourcing: Switch selectable N.O./N.C.

Sourcing output current:

Maximum 100 mA

Current limit protected to less than 160 mA

AC Models:

Triac, switch selectable N.O./N.C.

Maximum continuous load current: 1 Amp

Maximum applied output voltage: 260 VAC

Maximum off-state leakage current: less than

50 µA (100% PLC/AC input interface compatibil-  
ity)

# Selection Chart

## SM500 Series Proximity

Model No.	Power		Connection Style	Sensing Range				Transducer Style		Transducer Materials				Fast Response	Default Windows	Special Features
	100-240 VAC	12-24 VDC		Cable	Connector	2m (79")	1 m (39")	635mm (25")	254mm (10")	Standard	Remote	Rt. Angle	Straight			
SM500A-000•	■	■	(10")													
SM500A-000 AB	■	■														RS232 ( 4 digit/2-decimal place) output
SM500A-000 FS	■	■														
SM500A-000 R2	■	■								(20°)						
SM500A-000 R3	■	■								(30°)						
SM500A-000 R4	■	■								(40°)						
SM500A-000 S1	■	■									(10°)					
SM500A-000 S2	■	■									(20°)					
SM500A-000 S4	■	■									(40°)					
SM500A-044	■	■												± 0.1"		Hysteresis: 0.05, 0.2" W,0 Limit
SM500A-075	■	■												± 0.5"/-0.25"		High Gain
SM500A-080	■	■														Delay: Divide by 10 output
SM500A-091	■	■												± 0.05"		Hysteresis: 0.02 ± 0.0625" automatic setup window
SM500A-091 AA	■	■												± 0.05"		Hysteresis: 0.02 ± 0.0625" automatic setup window, Remote Limit Setup
SM500A-091 R2	■	■								(20°)				± 0.05"		Hysteresis: 0.02 ± 0.0625" automatic setup window
SM500A-091 R4	■	■								(40°)				± 0.05"		Hysteresis: 0.02 ± 0.0625" automatic setup window
SM500A-100•	■	■														
SM500A-100 AE	■	■														RS232 (5 digit/3 decimal place) output
SM500A-100 FS	■	■														
SM500A-100 R2	■	■								(20°)						
SM500A-100 R3	■	■								(30°)						
SM500A-100 R4	■	■								(40°)						
SM500A-100 S3	■	■									(30°)					
SM500A-191 R3	■	■								(30°)						
SM500A-400•	■	■														
SM500A-400 AA	■	■														Remote Limit Setup
SM500A-400 S1	■	■									(10°)					
SM520B-000•	■	■														
SM520B-000 FSS4	■	■									(40°)					
SM520B-000 R3	■	■								(30°)						
SM520B-000 R4	■	■								(40°)						
SM520B-000 S4	■	■									(40°)					
SM520B-075	■	■												± 0.5"/-0.25"		High Gain
SM520B-091	■	■												± 0.05"		Hysteresis: 0.02 ± 0.0625" automatic setup window
SM520B-100•	■	■														
SM520B-100 N	■	■														
SM520B-100 R3	■	■								(30°)						
SM520B-100R4	■	■								(40°)						
SM520B-144	■	■												± 0.1"		Hysteresis: 0.05, 0.2" W, 0 Limit
SM550A-000•	■	■														
SM550A-000 R1	■	■								(10°)						
SM550A-000 R2	■	■								(20°)						
SM550A-000 R3	■	■								(30°)						
SM550A-000 R4	■	■								(40°)						
SM550A-000 S1	■	■									(10°)					
SM550A-044	■	■												± 0.1"		Hysteresis: 0.05, 0.2" W, 0 Limit
SM550A-100•	■	■														
SM550A-100 R4	■	■								(40°)						
SM550A-144	■	■												± 0.1"		Hysteresis: 0.05, 0.2" W, 0 Limit
SM550A-400•	■	■														
SM550A-444	■	■												± 0.1"		Hysteresis: 0.05, 0.2" W, 0 Limit

# Selection Chart

## SM500 Series (cont.) Proximity

Model No.	Power		Connection Style	Cable	Sensing Range				Transducer Style		Transducer Materials				Fast Response	Default Windows	Other	Special Features
	100-240 VAC	Version			12-24 VDC	Connector	2m (79")	1 m (39")	635mm (25")	254mm (10")	Standard	Rt. Angle	Remote	Silicone*				
SM570B-000*	■			■		■		■	■			■		■				
SM570B-000 R2	■			■		■		■	■ (20°)			■		■				
SM570B-000 R3	■			■		■		■	■ (30°)			■		■				
SM570B-000 R4	■			■		■		■	■ (40°)			■		■				
SM570B-000 S2	■			■		■		■		■ (20°)		■		■				
SM570B-091	■			■		■		■				■		■		± 0.05"		Hysteresis: 0.02 ± 0.0625" automatic setup window
SM570B-100*	■			■		■		■	■			■		■				
SM570B-100 R2	■			■		■		■	■ (20°)			■		■				
SM570B-100 R3	■			■		■		■	■ (30°)			■		■				
SM570B-100 R4	■			■		■		■	■ (40°)			■		■				
SM570B-100 S3	■			■		■		■		■ (30°)		■		■				
SM570B-100 S4	■			■		■		■		■ (40°)		■		■				
SM570B-144	■			■		■		■				■		■		± 0.1"		Hysteresis: 0.05, 0.2" W, 0 Limit

• = Most commonly stocked sensors

\* = See definition in *Sensing Terms*.

All possible sensor configurations are not listed here.

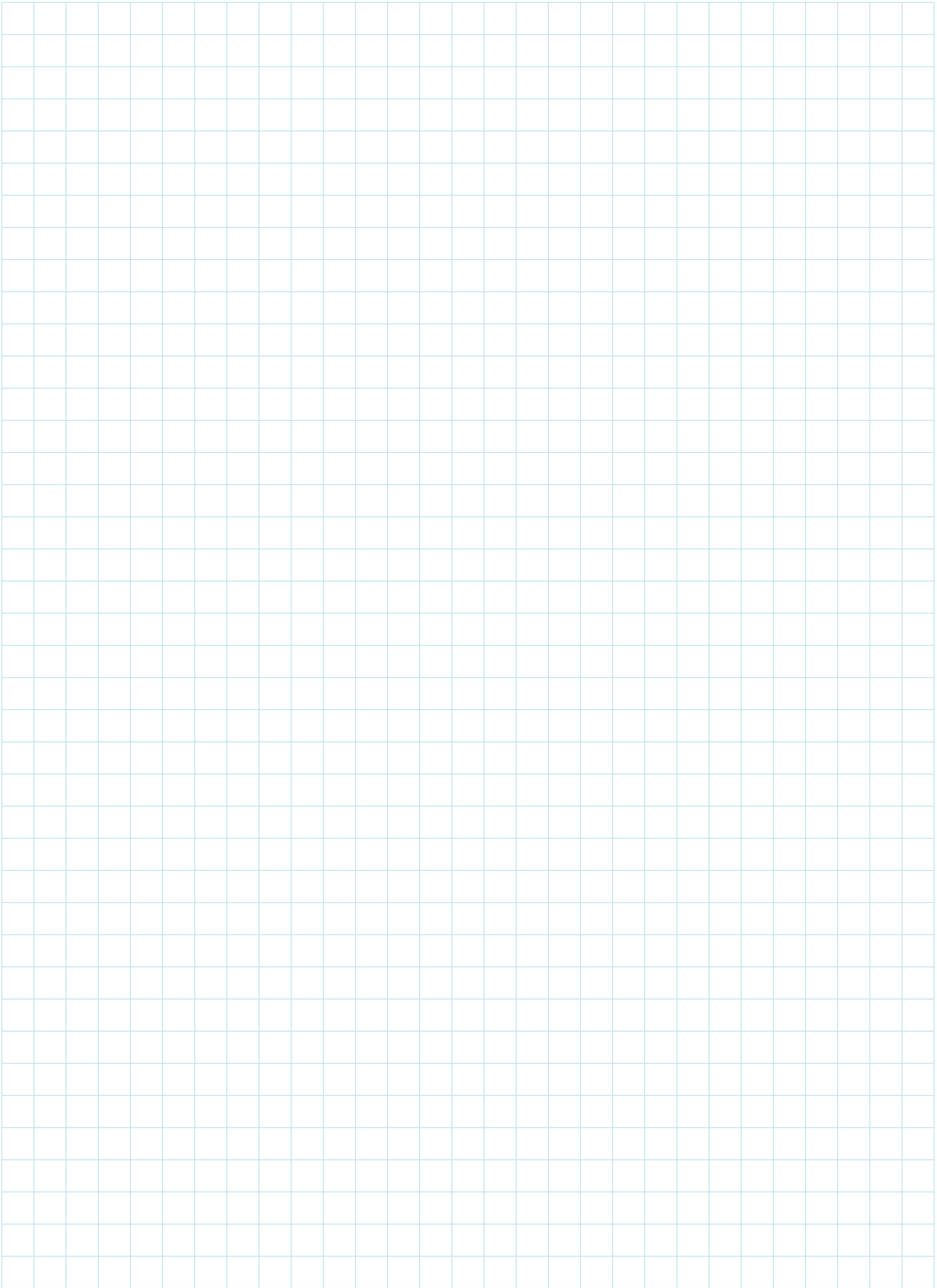

## Model SM502 Series

### SUPERPROX® Ultrasonic Dual-Level Sensors



The SUPERPROX® ultrasonic sensors with on/off latch-control output are now available for a wide variety of dual-level control applications. All AC-powered models operate over a 100 to 240 voltage range and there are

DC-powered models available with high and low alarm outputs for critical control requirements. The DC models are also available with a sensing range of 2 m (79").

Capable of reliable monitoring and controlling most liquid and granular materials within the level sensing range, these self-contained sensors are typically used in such applications as opening and closing a valve or starting and stopping a pump.

This ultrasonic sensor series (Model SM502 through Model SM572) offers easy setup, dependable operation, and compatible integration with most programmable logic controllers. Each sensor is epoxy sealed to withstand harsh, wet, messy, dusty, and dirty environments typically associated with level-control applications. The SUPERPROX® housings meet NEMA 4X and IP67 industry standards. A Dairy 3A approved housing is available as an option.

- *Easy push-button setup for the specific application*
- *Dual-level on/off latch or dual-level on/off latch with high and low alarm*
- *Noncontact sensing range up to 2 m (79")*
- *Epoxy sealed in tough ULTEM® housing*
- *Virtually impervious to the harshest environments*
- *CE certified*
- *AC-powered models ETL listed*

SUPERPROX® SM502  
SERIES

## Introduction

Hyde Park's self-contained, SUPERPROX<sup>®</sup>, dual-level sensors are capable of monitoring and controlling most nonhazardous liquid or dry material levels within a sensing range of either 51mm to 1 m (2 to 39") or 120 mm to 2 m (4.7 to 79"). An ON/OFF latched output is provided by the sensor relative to two level limit set points. The output is used for controlling material levels in tanks, hoppers, reservoirs, etc. as well as loop levels or tension on web processing lines.

These dual-level sensor models are available in three basic operating functions, each of which offers one or more options. The Model Reference Guide on this page lists and identifies the three functions and options under "Functionality".

The specific description of each function can be found under these suffixes on the following pages.

## Control Compartment

A unique feature available to the user of these sensors is the facility to quickly set them up for a specific application. These sensors are configured through two to four slide switches and one to two push-buttons located inside the watertight control compartment on the sensor. The control compartment for each of the three operating functions is illustrated on the following pages.

To access the control compartment, remove the small square cover on the back of the sensor. Simply loosen the two flat-head cover screws and insert a small blade screwdriver in either the top or bottom slot to remove the cover. A short plastic tether prevents separation of the cover from the sensor.

## Sensor Limits Setup Push-button

First, during installation, make sure the sensor face is as parallel as possible to the surface of the material being detected.

To set the level limits, simply place an object at the desired distance from the sensor for one limit and press the LIMITS push-button once. This sets the first limit. While the LIMITS push-button is depressed, the multicolored LED, located on top of the sensor, is amber. Upon release of the push-button, the LED flashes amber indicating that the second limit needs to be set. Place an object at the desired position for the second limit and press the LIMITS push-button once. Again, while the push-button is depressed, the LED is amber.

Upon release of the push-button, the LED flashes amber momentarily and then turns green to indicate acceptance of both limits.

At the same time, the sensor output

switches from an inactive to active state, placing the sensor in the operational mode, ready to use. When power is off or interrupted, the limits are retained in a nonvolatile memory.

## Model Reference Guide - SM502 Series

Use the guide below to ensure the correct model number is specified for the application. Please note that not all sensor model combinations are available.

### EXAMPLE MODEL:

**SM5 0 2 A - 1 73 - LE N R 4**

### SUPERPROX<sup>®</sup> Product Series

#### Power/Connection Type

- 0...12 to 24 VDC / cable style
- 2...100 to 240 VAC / cable style
- 5...12 to 24 VDC / connector style
- 7...100 to 240 VAC / connector style

#### Sensing Function

- 2...Proximity - dual level

#### Design Level

- A...Applies to all DC-powered models
- B...Applies to all AC-powered models

#### Sensing Range

- 1...51 to 1 m (2 to 39")
- 4...120 mm to 2 m (4.7 to 79")

#### Functionality

- 00...ON/OFF Latch control
- 14...ON/OFF Delay latch control
- 19...ON/OFF Delay latch control / default window: +0/- .25"
- 20...ON/OFF Latch control / Fast response: 20 ms ON/OFF response
- 44...ON/OFF Latch control / default window: ±0.100"
- 72...ON/OFF Latch control with dual alarms\*\* / default window: ±0.25",  
delay 30 sec or x with switch selectable setup
- 73...ON/OFF Latch control with dual alarms\*\*
- 74...ON/OFF Latch control with dual alarms\*\* / default window: ±0.125"
- 76...ON/OFF Latch control with dual alarms\*\* / inverted NPN output

#### Special Features

- ... No letter indicates standard sensor with no special features
- LE... No change in output on loss of echo
- FS... Fluorosilicone transducer face
- AA... Remote limit setup (Available on cable models only.)
- AB... RS232, 4-digit/2-decimal place output (Available on cable models only.)
- AD... Limits push-button disabled
- AE... RS232, 5-digit/3-decimal place output (Available on cable models only.)
- AF... No LEDs

#### Housing Types

- ...No letter indicates standard ULTEM<sup>®</sup>\* plastic housing
- N...NORYL<sup>®</sup>\* Dairy 3A gray plastic housing

#### Remote Type

- ... No letter indicates standard housing
- R...Right-angle sensing head with armor cable
- S...Straight sensing head with armor cable

#### Remote Cable Length

- ... No number indicates standard housing

- 1...254 mm (10")
- 2...508 mm (20")
- 3...762 mm (30")
- 4...1016 mm (40")
- 5P...1270 mm (50")
- 6P...1524 mm (60")

} Armored (standard) or PVC cable (specify P after number)

} Available in PVC cable only

\* ULTEM<sup>®</sup> and NORYL<sup>®</sup> are registered trademarks of The General Electric Company.

\*\* Alarms available on DC-powered models only.

NOTE: SM522 and SM572 AC models carry the ETL safety label



If in setting either level limit the echo from the object is too weak or distorted, the LED flashes red for 10 seconds (or until the button is pressed again) indicating the limit setting was not accepted by the sensor. Attempt to set both limits again, being careful to keep the object surface parallel to the face of the sensor.

Minimum allowed distance between limits is 13 mm (1/2"). The multicolored LED flashes red after the press and release of the LIMITS push-button for the second limit setting if the distance between the limit settings is less than 13 mm. The multicolored LED continues flashing red either until the LIMITS push-button is pressed and released once for the first limit setting or until 10 seconds have elapsed. Pressing and releasing the LIMITS push-button once reinitiates the limit setup sequence. If 10 seconds elapse before the LIMITS push-button is pressed and released for the second limit setup, the limits revert back to the previous settings.

### Loss of Echo

Loss of echo occurs when the sensor does not receive echoes from an object within its sensing range for more than one second. When this occurs, the sensor's output automatically switches OFF. When the sensor again receives echoes from a level, the output will either switch or remain in the same state depending on where the echoes are received relative to the level control limits.

### "LE" Option

The LE suffix in the Model Reference Guide indicates an available option for users who do not prefer the standard response to loss of echo. With the LE option, when loss of echo occurs for more than one second, there is no change in the output state of the sensor. When the sensor again receives echoes, the output assumes the state relative to the control limit set points.

### Function "00", "20", "44" ON/OFF Latch Control

This dual-level sensor function allows two level limits, high and low, within which the level of product is to be controlled. As the product level moves above the high limit or below the low limit, the sensor output switches state and latches either ON or OFF to, for example, close or open a valve and stop or run a pump. The output remains latched in the ON or OFF state until the product level moves back beyond the other limit, at which time the output switches state.

### Sensor Operating Profile

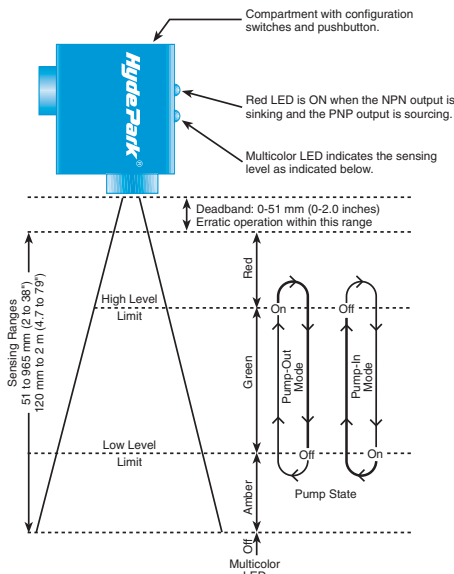

### Function "00", "20", "44" Control Compartment

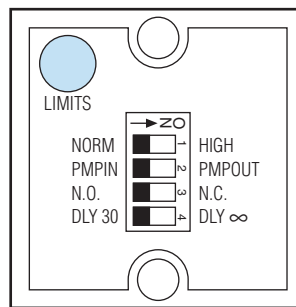

### Function "00", "20", "44" Sensor Configuration Switches

**Switch 1** configures the sensor to operate in either a normal or high sensitivity mode. Place this switch in the NORM position for sensing smooth liquid or solid material levels. Place the switch in the HIGH position for sensing turbulent liquid levels and soft or porous material that will deflect or absorb some of the ultrasonic energy.

**Switch 2** configures the sensor output to perform either a pump in or pump out control function. Place this switch in the PMPIN position to control the filling process and prevent an overflow of a vessel. Place the switch in the PMPOUT position to control an emptying process and prevent the complete drawdown of a vessel.

### Pump-In Mode

When the level moves below the low limit, the sensor output switches state and latches, starting a pumping process. The sensor output does not change state until the level moves back above the

high limit to stop the pumping process.

### Pump-Out Mode

When the level moves below the low limit, the sensor output switches state and latches, stopping a pumping process. The sensor output does not change state until the level moves back above the high limit to restart the pumping process.

**Switch 3** selects the operating mode for the sensor output to be either normally open (N.O.) or normally closed (N.C.).

**Switch 4** selects the allowable time for setting the high and low limits. If the switch is in the DLY 30 position, the allowed setup time is 30 seconds. If the switch is in the DLY ∞ position, the setup time is infinite.

### Function "14", "19", On/Off Delay Latch Control

This function operates the same as described for the Function "00", "20", and "44" models, with one exception. The Function "14" and "19" models allow programmable on/off delay time adjustments of the sensor output. As the level moves above the high limit or below the low limit, the sensor output switches and latches either on or off, following the programmed delay time, in performing the required control function. As the level moves back beyond the limit, the output switches and latches back to its other state following, again, the programmed delay time in performing the required control function.

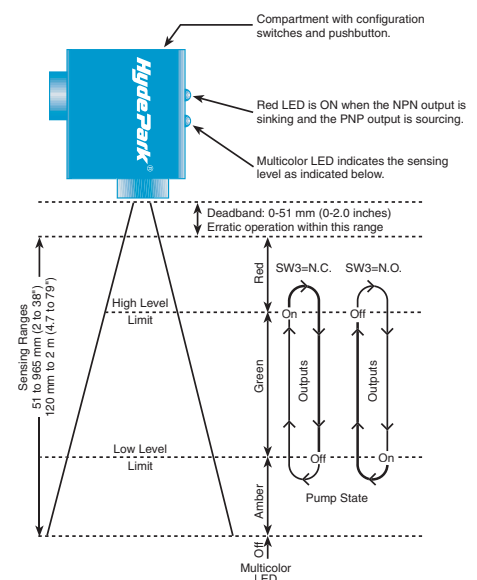

## Function “14”, “19” Control Compartment

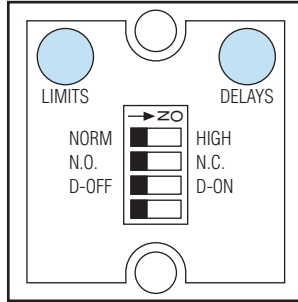

## Function “14”, “19” Sensor Configuration Switches

**Switch 1** configures the sensor to operate in either a normal or high sensitivity mode. Place this switch in the NORM position for sensing smooth liquid or solid material levels. Place the switch in the HIGH position for sensing turbulent liquid levels and soft or porous material that will deflect or absorb some of the ultrasonic energy.

**Switch 2** selects the operating mode for the sensor output to be either normally open (N.C. is pump out) or normally closed (N.O. is pump in).

**Switch 3** selects the delay time program mode for setting the desired ON and OFF delay times through the DELAYS push-button. See Delay Time Setup for switch operation.

**Switch 4** is not used.

## Delay Time Functions

The ON delay time prevents the sensor output state from immediately switching active when the sensor starts sensing the level outside that respective level limit set point. The output switches active only after the sensor has continued sensing the level outside that respective level limit set point for the entire ON delay time period.

The OFF delay time prevents the sensor output state from immediately switching inactive when the sensor starts sensing the level outside that respective level limit set point. The output switches inactive only after the sensor has discontinued sensing the level outside that respective level limit set point for the entire OFF delay time period.

## Delay Time Setup

Place Switch 3 in the D-OFF position for setting the desired OFF delay time. Press the DELAYS push-button for the length of the desired delay time. The multicolored LED indicator on the sensor momentarily flashes green after release of the DELAYS push-button to acknowledge the delay time has been set into the nonvolatile memory of the sensor.

Place Switch 3 in the D-ON position for setting the desired ON delay time. Press the DELAYS push-button for the length of the desired delay time. The multicolored LED indicator on the sensor momentarily flashes green after release of the DELAYS push-button to acknowledge the delay time has been set into the nonvolatile memory of the sensor.

## Resetting Delay Times

Place Switch 3 in the D-OFF position and press the DELAYS push-button two successive times for resetting the OFF delay time to the minimum response time. Perform the same process with Switch 3 in the D-ON position for resetting the ON delay time to the minimum response time. The multicolored LED indicator on the sensor momentarily flashes green after the second release of the DELAYS push-button to acknowledge the delay time has been reset to the minimum response time.

## Function “72”, “73”, “74”, “76” On/Off Latch Control with Dual Alarms

This dual-level, on/off latch-control sensor function is, again, similar in operation to the Function “00”, “20”, and “44” sensors in that it also allows two level limits, a high and low, within which the level of product is to be controlled. An added feature enables the user to set two discrete alarm set points anywhere within the sensing range where alarm outputs are required to protect the equipment from potential damage.

This function is only available in DC-powered models having current sinking, NPN outputs. Current sourcing, PNP outputs are not available.

## Sensor Operating Profile

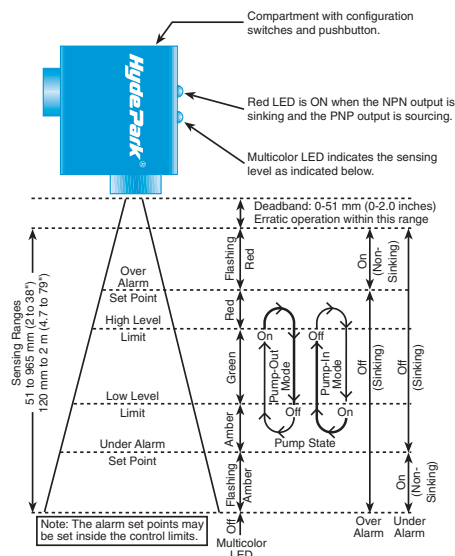

## Function “72”, “73”, “74”, “76” Control Compartment

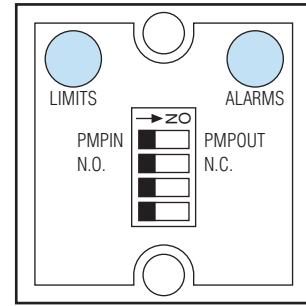

## Function “72”, “73”, “74”, “76” Sensor Configuration Switches

**Switch 1** configures the sensor output to perform either a pump in or pump out control function. Place the switch in the PMPIN position to control the filling process and prevent an overflow of a vessel. Place the switch in the PMPOUT position to control an emptying process and prevent the complete drawdown of a vessel.

### Pump-In Mode

When the level moves below the low limit, the sensor output switches state and latches, starting a pumping process. The sensor output does not change state until the level moves back above the high limit to stop the pumping process.

### Pump-Out Mode

When the level moves below the low limit, the sensor output switches state and latches, stopping a pumping process. The sensor output does not change state until the level moves back above the high limit to restart the pumping process.

**Switch 2** selects the operating mode for the sensor output to be either normally open (N.O.) or normally closed (N.C.).

**Switch 3** and **Switch 4** are not used.

## Dual-Alarm Outputs

The dual-alarm outputs in the Function “72”, “73”, “74”, and “76” sensors operate in a fail-safe manner. The alarms are normally ON, conducting or sinking, with the level inside both alarm limits. For example, the high alarm output switches OFF when the level rises above the high alarm limit. Conversely, the low alarm switches OFF when the level drops below the low alarm limit.

## Loss of Echo and the “LE” Option

Like the outputs of the other dual-level sensors, the dual-alarm outputs in the Function “72”, “73”, “74”, and “76” sensors also switch OFF with a loss of echo condition. Upon echo restoration, both alarm outputs switch ON when the level is inside both alarm limits. Should the level be outside one of the alarm limits, that alarm output will remain OFF.

With the “LE” option, when loss of echo occurs for more than one second, there is no change in either the control level or alarm level output states of the sensor. When the sensor again receives echoes from within its sensing range, those outputs assume the state relative to the control and alarm limit set points.

## Multicolored LED Indicator During Alarm Setup Mode for Function “72”, “73”, “74”, and “76” Sensors

Press and release the ALARMS push-button with the level at the desired low alarm limit.

- Flashing Amber - Low alarm limit is set.

Press and release the ALARMS push-button with the level at the desired high alarm limit.

- Flashing Red - High alarm limit is set.

IMPORTANT: When either one of the alarm limits is reset for a different level, the other alarm limit must also be reset.

## Multicolored LED Indicator in Operational Mode for Function “72”, “73”, “74”, and “76” Sensors

There are four possible setup mode combinations for setting where the alarm level outputs are inactive with respect to the control level output. The table below illustrates the LED status colors for all four alarm limit setup combinations.

### Setup Combination 1:

High Alarm Level	Flashing Red
High Control Level	Red
Low Control Level	Green
Low Alarm Level	Amber
	Flashing Amber

### Setup Combination 2:

High Control Level	Flashing Red
High Alarm Level	Flashing Red
Low Alarm Level	Green
Low Control Level	Flashing Amber
	Flashing Amber

### Setup Combination 3:

High Control Level	Flashing Red
Low Control Level	Flashing Red
High Alarm Level	Flashing Red
Low Alarm Level	Amber
	Flashing Amber

### Setup Combination 4:

High Control Level	Flashing Red
High Alarm Level	Flashing Red
Low Control Level	Green
Low Alarm Level	Amber
	Flashing Amber

## Electrical Wiring

Sensor wires must be run in conduit free of any AC power or control wires.

### Sensor Wire Colors

#### DC Models, 4-Conductor

	Cable Style	Connector Style
(+) 12 to 24 VDC	RED	BROWN
NPN/Sinking Output	WHITE	BLACK
PNP/Sourcing Output	GREEN	WHITE
Common	BLACK	BLUE

#### DC Models, 5-Conductor

(+) 12 to 24 VDC	RED	BROWN
Control Level, NPN/Sinking Output	WHITE	BLACK
Low Alarm Level NPN/Sinking Output	BROWN	ORANGE
High Alarm Level NPN/Sinking Output	GREEN	WHITE
Common	BLACK	BLUE

#### AC Models, 4-Conductor

100 to 240 VAC	BROWN	BROWN
Switch Line Side	BLACK	BLACK
Switch Load Side	WHITE	WHITE
Neutral	RED	BLUE

## DC Outputs

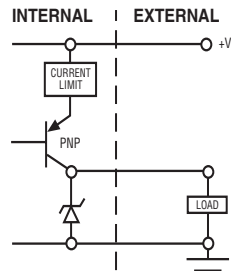
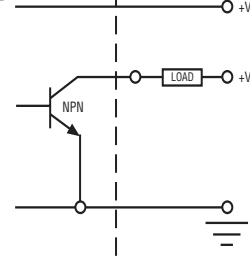

## AC Outputs

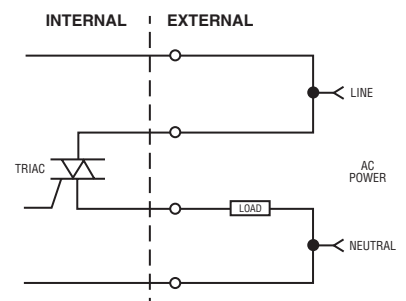

## View of Plug on Connector Style Sensors

### DC Power Models

(4-Pin, Functions “00”, “14”, “19”, “20”, and “44”)

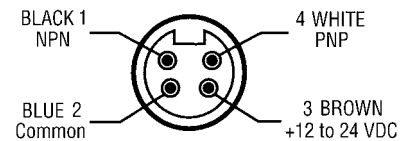

(5-pin, Functions “72”, “73”, “74”, and “76”)

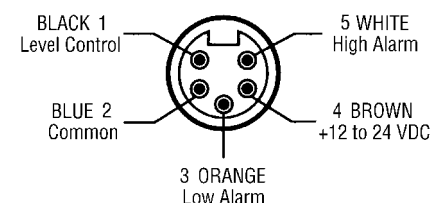

### AC Power Models

(4-Pin, Functions “00”, “14”, “19”, “20”, and “44”)

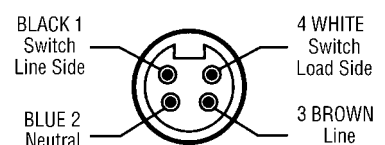

## Sensor Wire Connectors

### DC Models

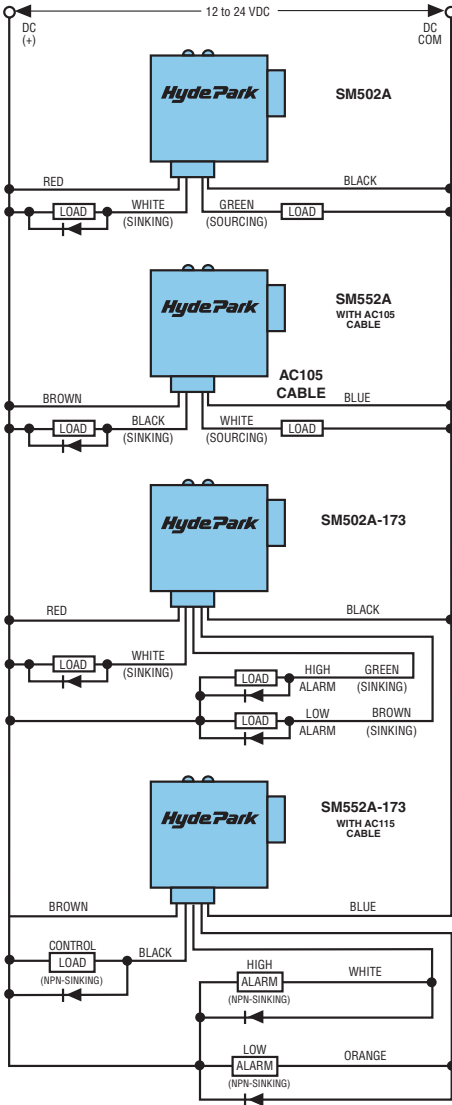

### AC Models

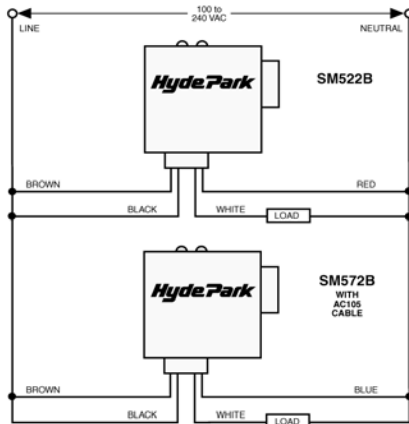

## Dimensions

### Cable Model

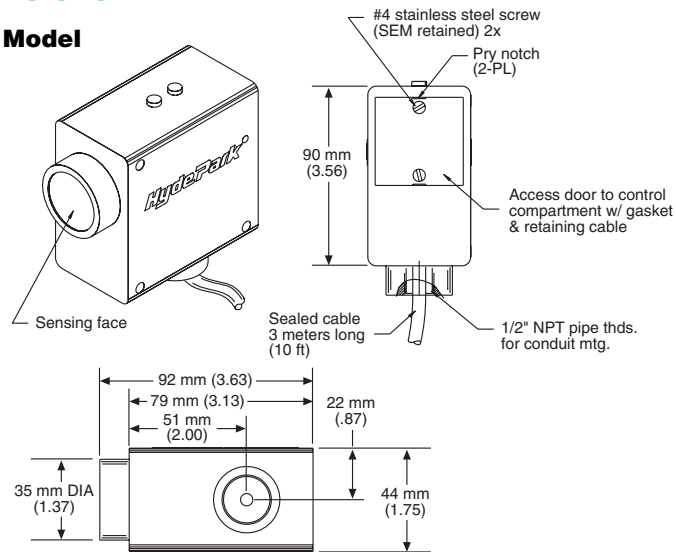

### Connector Model

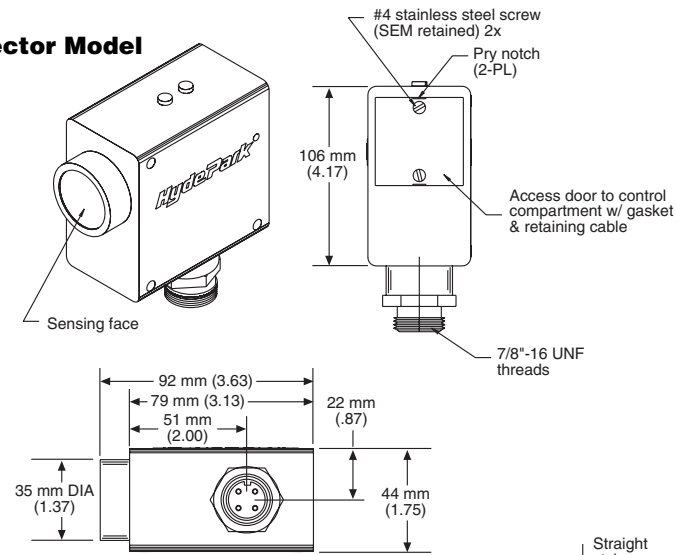

### Remote Sensing Models

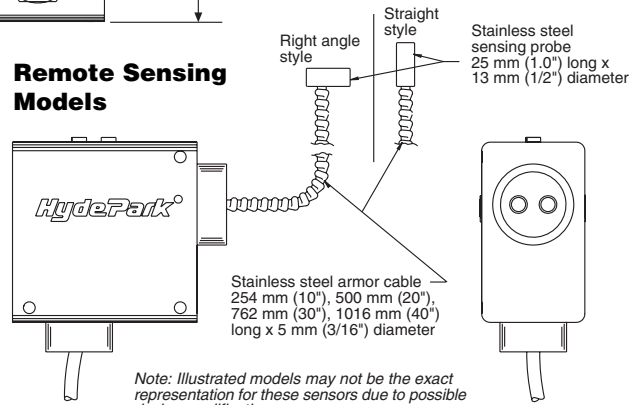

## Mounting Accessories

### AC230

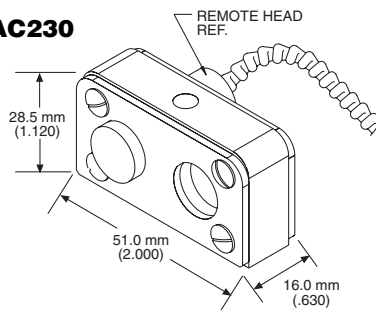

### AC213

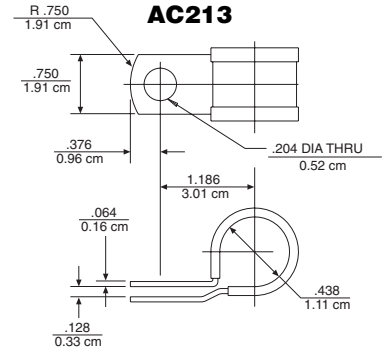

## Mounting Accessories

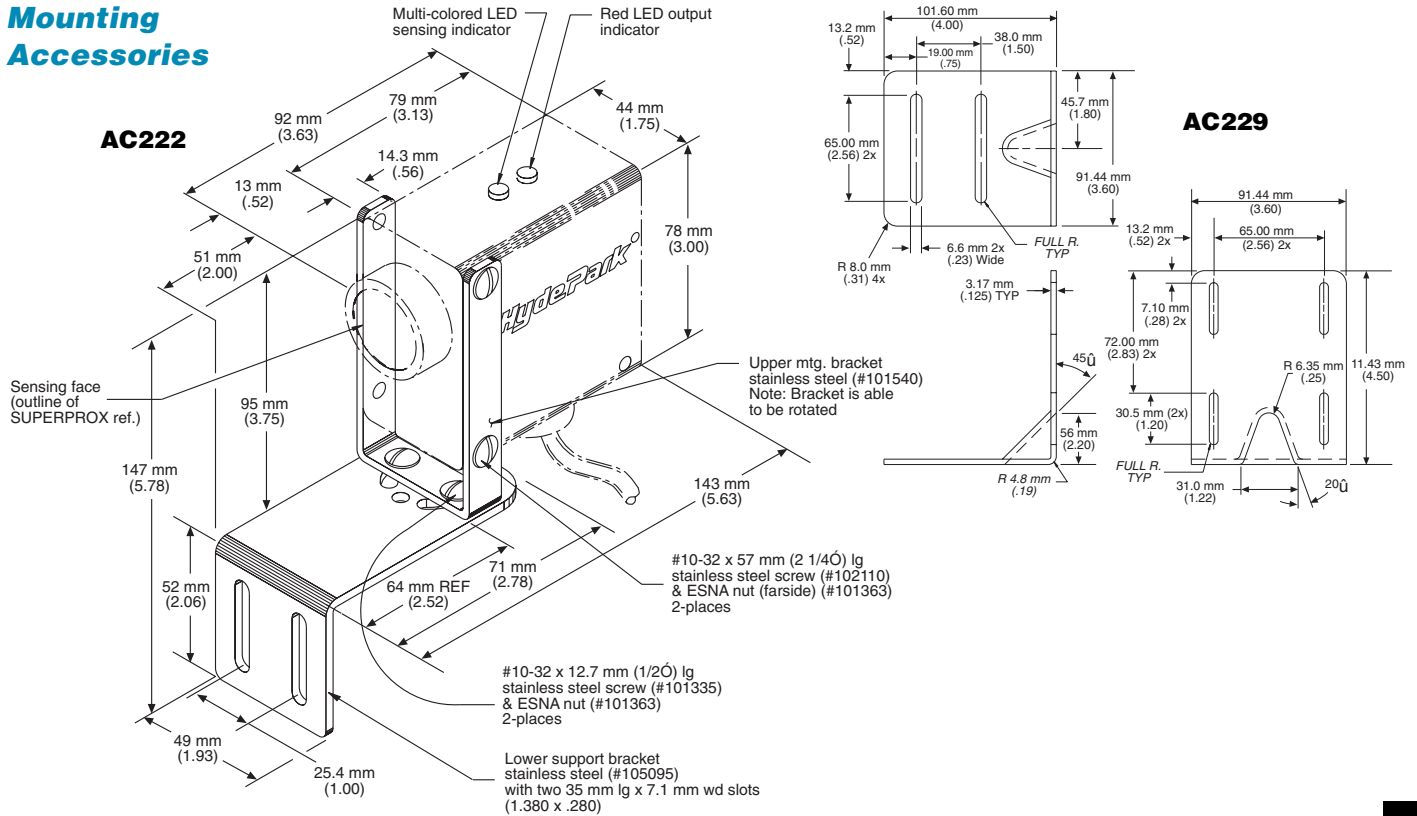

## General Specifications

### Sensing

- Ranges:  
 51 to 1 m (2 to 39")  
 120 mm to 2 m (4.7 to 79" - DC Model only)  
 Sonic Frequency: 200 kHz

### Power Requirements

- DC Models:  
 12 to 24 VDC  $\pm$  10% @ 80 mA, 2 W max.,  
 excluding output load (regulated supply)  
 AC Models:  
 100 to 240 VAC, 50/60 Hz, @ 30 mA, 7.5 VA  
 max., excluding load

### Outputs

- DC Models:  
 NPN Sinking: Switch selectable N.O./N.C.  
 Sinking on-state voltage drop:  
 Maximum 0.25 volts @ 60 mA  
 Sinking load current:  
 Maximum 100 mA  
 Sinking output voltage:  
 Maximum applied 30 VDC  
 PNP Sourcing: Switch selectable N.O./N.C.  
 Sourcing output current:  
 Maximum 100 mA  
 Current limit protected to less than 160 mA  
 AC Models:  
 Triac, switch selectable N.O./N.C.  
 Maximum continuous load current: 1 Amp  
 Maximum applied output voltage: 260 VAC  
 Maximum off-state leakage current: less than  
 50  $\mu$ A (100% PLC/AC input interface compatibility)

### Response Time

- "On" 200 ms, "Off" 200 ms to  
 "On" 400 ms, "Off" 400 ms, depending upon model

### Indicators

- Multicolored (Amber, Red, Green) LED:  
 Indicates limits setup and operational modes

Red LED: Visual indicator for sensor output;  
 illuminated when output is in an active (on) state

### Connections

- Cable Style Models:  
 DC: 24 AWG, PVC jacket,  
 4- or 5-conductor, 3 meters (10') long,  
 standard  
 AC: 20 AWG, PVC jacket,  
 4-conductor, 3 meters (10') long, standard  
 Connector Style Models:  
 DC: 4- or 5-pin "mini" style  
 AC: 4-pin "mini" style

### Protection

- Power Supply: current-limited over-voltage, ESD,  
 reverse polarity, fuse on AC Model  
 Outputs: current-limited over voltage, ESD,  
 over-current, fused TRIAC on AC Model

### Environmental

- Operating Temperature Range:  
 0° to 50°C (32° to 122°F)  
 Storage Temperature Range: -40° to 100° C  
 (-40° to 212°F)  
 Operating Humidity: 100%  
 Protection Ratings: NEMA 4X, IP67  
 Chemical Resistance: Resists most acids and  
 bases, including most food products.  
 Fluorosilicone transducer face is available to  
 provide resistance to aromatic and petroleum-  
 based hydrocarbons.

### Agency Approvals

- CE Mark: CE conformity is declared to:  
 EN61010-1: 1990 including amend. No.1:1992  
 EN55011 Group 1 Class A, EN50082-1.  
 Declaration of conformity available upon request  
 AC Models SM522/572 carry the ETL safety label.

### Construction

- Dimensions (overall)  
 92 mm (3.625") L x 44 mm (1.75") W x 91 mm  
 (3.58") H

### Housing:

- Case: ULTEM®\* (FDA approved)  
 Optional: NORYL®\* (USDA-Dairy 3A  
 Sanitary Standards compliant)  
 Transducer Face: Silicone rubber (FDA  
 approved)  
 Optional: Fluorosilicone rubber  
 Sensor Cable: PVC jacket  
 LED: Polycarbonate

\* ULTEM® and NORYL® are registered trademarks of The  
 General Electric Co.

## Accessories

- Model AC105**, Straight, 7/8-16 mini, 4-conductor,  
 mating connector cable, 4 m (12'), for connector-  
 style sensors  
**Model AC105-50**, Straight, 7/8-16 mini, 4-conductor,  
 mating connector cable, 15 m (50'), for connector-  
 style sensors  
**Model AC115**, Straight, 7/8-16 mini, 5-conductor,  
 mating connector cable, 4 m (12'), for Model  
 SM552A-X7X series dual-level sensors  
**Model AC115-50**, Straight, 7/8-16 mini, 5-conductor,  
 mating connector cable, 15 m (50'), for Model  
 SM552A-X7X series dual-level, connector-style  
 sensors  
**Model AC213**, Stainless and Teflon, remote sensing  
 probe mounting bracket  
**Model AC222**, Standard, stainless mounting bracket  
 assembly, slotted for vertical adjustment  
**Model AC229**, Stainless, plate-style, right-angle,  
 mounting bracket, with base slotted for forward/  
 reverse adjustment and side slotted for sensor  
 adjustment  
**Model AC230**, Three-piece, stainless, mounting  
 bracket assembly with O-ring mount for sensor  
 models with remote heads.

See page 7-1 for accessory photos.

# Selection Chart

## SM502 Series Dual-Level

Model No.	Power Version		Connection Style	Sensing Range			Transducer Style		On/Off Output Options				Materials				Loss of Echo □		Notes	Special Features
	100-240 VAC	12-24 VDC		Cable Connector	2m (79")	1m (39")	Standard	Remote Rt. Angle	Straight	Latch Control	Delay Latch Control	Latch Control w/ Dual Alarms	Silicone*	Fluorosilicone*	ULTEM®*	NORYL®*	Default Window	Default Window		
SM502A-100•	■	■	■	■	■	■			■			■		■						
SM502A-100 FS	■	■	■	■	■	■			■				■	■						
SM502A-100 LE•	■	■	■	■	■	■			■			■		■						
SM502A-100 S2	■	■	■	■	■	■		■ (20°)	■			■		■						
SM502A-114	■	■	■	■	■	■						■		■						
SM502A-114 LE	■	■	■	■	■	■						■		■						
SM502A-119	■	■	■	■	■	■						■		■						
SM502A-119 LE	■	■	■	■	■	■						■		■						
SM502A-173•	■	■	■	■	■	■						■		■						
SM502A-173 FS	■	■	■	■	■	■							■	■						
SM502A-173 LE	■	■	■	■	■	■						■		■						
SM502A-173 LES4	■	■	■	■	■	■		■ (40°)	■			■		■						
SM502A-173 N	■	■	■	■	■	■						■		■						
SM502A-173 R2	■	■	■	■	■	■		■ (20°)	■			■		■						
SM502A-173 R4	■	■	■	■	■	■		■ (40°)	■			■		■						
SM502A-173 S4	■	■	■	■	■	■		■ (40°)	■			■		■						
SM502A-174	■	■	■	■	■	■						■		■			±0.125"			
SM502A-176	■	■	■	■	■	■						■		■					Inverted NPN Alarm Outputs	
SM502A-400•	■	■	■	■	■	■						■		■						
SM502A-400 LE	■	■	■	■	■	■						■		■						
SM502A-473	■	■	■	■	■	■						■		■						
SM502A-473 LE	■	■	■	■	■	■						■		■						
SM522B-100•	■	■	■	■	■	■						■		■						
SM522B-100 FS	■	■	■	■	■	■							■	■						
SM522B-100 LE	■	■	■	■	■	■						■		■						
SM522B-100 R3	■	■	■	■	■	■		■ (30°)	■			■		■						
SM522B-100 R4	■	■	■	■	■	■		■ (40°)	■			■		■						
SM522B-114	■	■	■	■	■	■						■		■						
SM522B-114 LE	■	■	■	■	■	■						■		■						
SM522B-144	■	■	■	■	■	■						■		■			±0.100"			
SM552A-100•	■	■	■	■	■	■						■		■						
SM552A-100 LE	■	■	■	■	■	■						■		■						
SM552A-100 R4	■	■	■	■	■	■		■ (40°)	■			■		■						
SM552A-114	■	■	■	■	■	■						■		■						
SM552A-114 LE	■	■	■	■	■	■						■		■						
SM552A-119 LE	■	■	■	■	■	■						■		■			±0/-0.25"			
SM552A-120	■	■	■	■	■	■						■		■					20 ms ON/OFF Response	
SM552A-172	■	■	■	■	■	■						■		■			±0.25"		Delay 30 sec. or × switch selectable	
SM552A-173	■	■	■	■	■	■						■		■						
SM552A-173 LE•	■	■	■	■	■	■						■		■						
SM552A-173 LES3	■	■	■	■	■	■		■ (30°)	■			■		■						
SM552A-173 R1	■	■	■	■	■	■		■ (10°)	■			■		■						
SM552A-173 R2	■	■	■	■	■	■		■ (20°)	■			■		■						
SM552A-173 R4	■	■	■	■	■	■		■ (40°)	■			■		■						
SM552A-174	■	■	■	■	■	■						■		■						
SM552A-176	■	■	■	■	■	■						■		■					Inverted NPN Alarm Outputs	
SM552A-400•	■	■	■	■	■	■						■		■						
SM552A-400 LEFS	■	■	■	■	■	■							■	■						
SM552A-400 LE	■	■	■	■	■	■						■		■						
SM552A-414 LE	■	■	■	■	■	■						■		■						
SM552A-472	■	■	■	■	■	■						■		■			±0.25"		Delay 30 sec. or × switch selectable	
SM552A-473	■	■	■	■	■	■						■		■						
SM552A-473 LE	■	■	■	■	■	■						■		■						
SM552A-473 R2	■	■	■	■	■	■		■ (20°)	■			■		■						
SM572B-100	■	■	■	■	■	■						■		■						
SM572B-100 FS	■	■	■	■	■	■							■	■						
SM572B-100 LE	■	■	■	■	■	■						■		■						
SM572B-100 LES2	■	■	■	■	■	■		■ (20°)	■			■		■						
SM572B-100 R4	■	■	■	■	■	■		■ (40°)	■			■		■						
SM572B-100 S1	■	■	■	■	■	■		■ (10°)	■			■		■						

# Selection Chart

## SM502 Series (cont.) Dual-Level

Model No.	Power		Connection		Sensing Range		Transducer Style		On/Off Output Options		Materials		Special Features			
	100-240 VAC	Version	Cable	Style	2m (79')	1m (39')	Rt. Angle	Remote	Latch Control	Delay Latch Control	Latch Control w/ DualAlarms	Transducer	Housing	Loss of Echo	Default Window	Notes
SM572B-114	■			■	■	■				■		■	■			
SM572B-114 LE	■			■	■	■				■		■	■	■		
SM572B-144	■			■	■	■			■			■	■	±0.100"		

• = Most commonly stocked sensors

\* = See definition in *Sensing Terms*.

All possible sensor configurations are not listed here.

No change in output on loss of echo

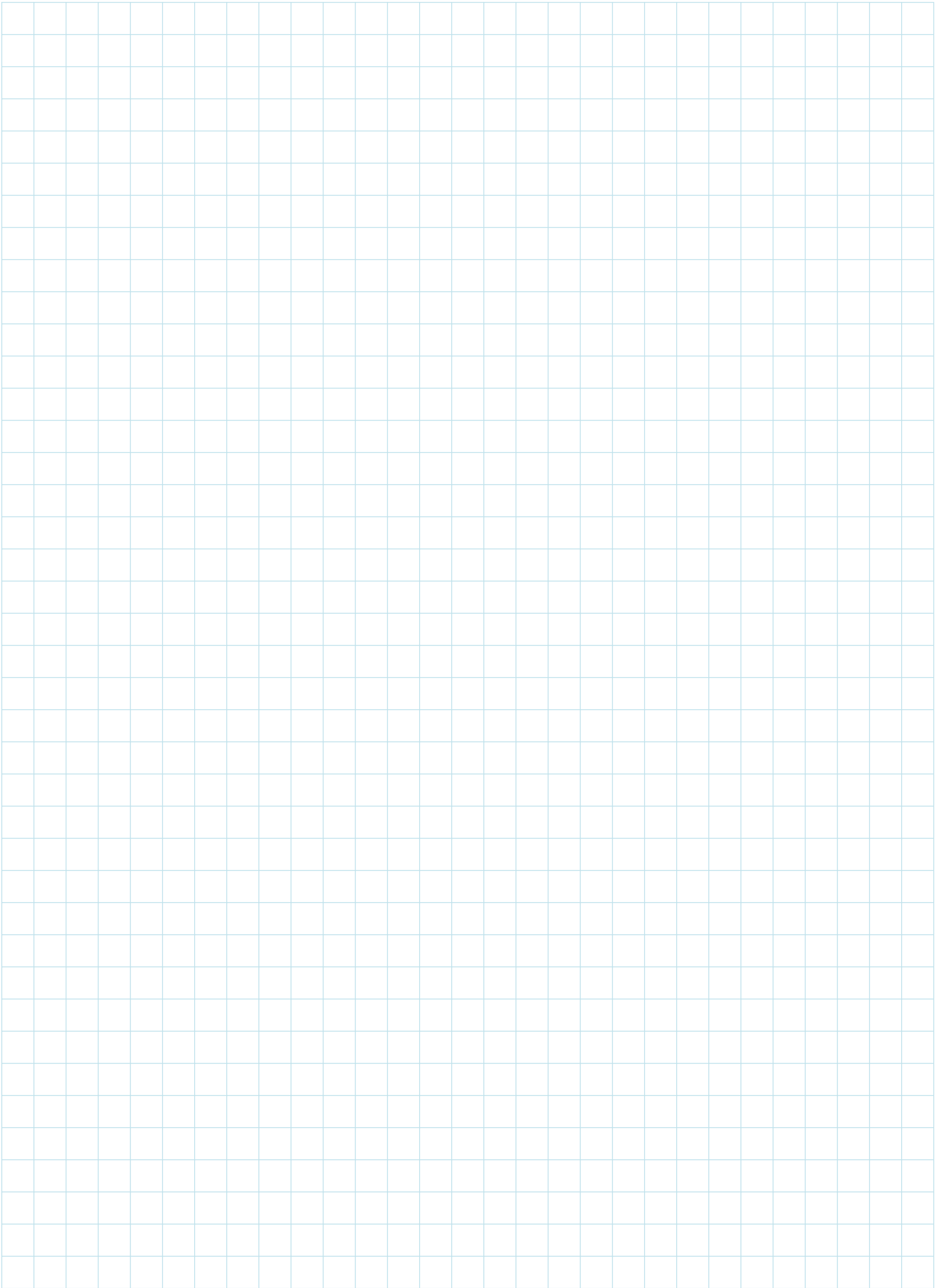



## Model SM503 Series

### SUPERPROX® Ultrasonic Proximity Sensors

### On/Off Delay Sensing



The versatile time-delay and sensing window setup features of the SUPERPROX® Model SM503 series of Hyde Park ultrasonic, proximity sensors are as easy as pressing a door bell.

Now available in either AC or DC power, the SM503 series is intended for applications

requiring reliable detection of objects and a delay of the output signal. Applications include jam and gap detection of all types of containers, even clear glass and P.E.T.

A convenient push-button in the rear control compartment gives the user the ability to quickly program when and how long the sensor output is delayed in switching to either the on or off state, or both. Once set, the sensor remains set with no periodic adjustments required.

Like other SUPERPROX® sensors, this series has a push-button for quickly setting the window limits within which the object is to be detected. These sensors are sealed for reliable sensing in harsh, wet, or dirty environments typically associated with many conveyor line, machine, and other automatic control sensing applications. The housing meets NEMA 4X and IP67 industry standards. A Dairy 3A compliant housing is available as an option.

- Easy push-button setup for the specific application
- Programmable On/Off delay
- Noncontact sensing range up to 2 m (79")
- Sensing limits and time delay(s) stored in nonvolatile memory
- Epoxy sealed in tough ULTEM® housing
- Virtually impervious to the harshest environments
- CE certified
- AC-powered models ETL approved

SUPERPROX® SM503  
SERIES

## Control Compartment

A unique feature available to the user of these sensors is the ability to quickly set up each sensor for a specific application. The sensor is configured through four slide switches and two push-buttons (See Figure 1) located inside a water-tight control compartment

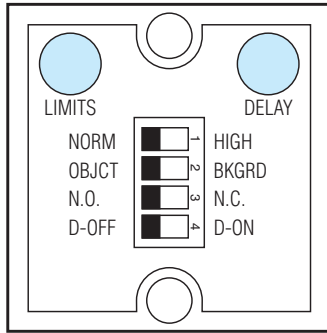

Figure 1

on the sensor. To access the controls, remove the small square cover on the back of the sensor. Simply loosen the two flathead cover screws and insert a small-blade screwdriver in either the top or bottom slot to remove the cover. A short plastic tether prevents separation of the cover from the sensor. NOTE: The switch settings may require changing for the intended application.

## Sensor Configuration Switches

**Switch 1** configures the sensor to operate in either a normal or high sensitivity mode. Place this switch in the NORM position for sensing liquid or solid materials. Place the switch in the HIGH position for sensing soft or porous materials that will absorb some of the ultrasonic energy.

**Switch 2** configures the sensor to operate in either an object or background sensing mode. Place this switch in the OBJCT position to perform a sensing function for receiving the reflected ultrasonic energy directly off an object. Place this switch in the BKGRD position to perform a break-beam sensing function for receiving the reflected ultrasonic energy directly off a fixed background target.

**Switch 3** selects the operating mode for the sensor output to be either normally open (N.O.) or normally closed (N.C.).

**Switch 4** selects the delay time program mode for setting the desired ON and OFF delay times through the DELAYS push-button. See Delay Time Setup for switch operation.

## Delay Time Functions

The ON delay time prevents the

sensor output state from immediately switching active when the sensor starts sensing an object inside the set window limits. The output switches active only after the sensor has continued sensing the object inside the set window limits for the entire ON delay time period.

The OFF delay time prevents the sensor output state from immediately switching inactive when the sensor stops sensing an object inside the set window limits. The output switches inactive only after the sensor has discontinued sensing the

object inside the set window limits for the entire OFF delay time period.

## Delay Time Setup

Place Switch 4 in the D-OFF position for setting the desired OFF delay time. Press the DELAYS push-button for the length of the desired delay time. The multicolored LED indicator on the sensor momentarily flashes green after release of the DELAYS push-button to acknowledge the delay time has been set into the nonvolatile memory of the sensor.

## Model Reference Guide - SM503 Series

Use the guide below to ensure the correct model number is specified for the application. Please note that not all sensor model combinations are available.

### EXAMPLE MODEL:

**SM5 0 3 A - 1 00 - FS R 2**

### SUPERPROX™ Product Series

#### Power/Connection Type

- 0...12 to 24 VDC / cable style
- 2...100 to 240 VAC / cable style
- 5...12 to 24 VDC / connector style
- 7...100 to 240 VAC / connector style

#### Sensing Function

- 3...Proximity - on/off delay

#### Design Level

- A...Applies to all DC-powered models
- B...Applies to all AC-powered models

#### Sensing Range

- 0...51 to 635 mm (2 to 25")
- 1...51 to 1m (2 to 39")
- 4...120 mm to 2 m (4.7 to 79")

#### Functionality

- 00...Standard proximity
- 15...Default window: ±1"
- 17...Special delay: 250 ms increment
- 25...Default window: +0.1"/-0.25"
- 44...Default window: ±0.1"
- 49...Special delay: 5 ms increment
- 91...Default window: ±0.05"

#### Special Features

- ... No letter indicates standard sensor with no special features
- FS... Fluorosilicone transducer face
- AA... Remote limit setup (Available on cable models only.)
- AB... RS232, 4-digit/2-decimal place output (Available on cable models only.)
- AD... Limits push-button disabled
- AE... RS232, 5-digit/3-decimal place output (Available on cable models only.)
- AF... No LEDs

#### Housing Types

- ...No letter indicates standard ULTEM® plastic housing
- N...NORYL® Dairy 3A gray plastic housing

#### Remote Type

- ... No letter indicates standard housing
- R...Right-angle sensing head with armor cable
- S...Straight sensing head with armor cable

#### Remote Cable Length

- ... No number indicates standard housing
  - 1...254 mm (10")
  - 2...508 mm (20")
  - 3...762 mm (30")
  - 4...1016 mm (40")
  - 5P...1270 mm (50")
  - 6P...1524 mm (60")
- Armored (standard) or PVC cable (specify P after number) Available in PVC cable only

\* ULTEM® and NORYL® are registered trademarks of The General Electric Company.

Place Switch 4 in the D-ON position for setting the desired ON delay time. Press the DELAYS push-button for the length of the desired delay time. The multicolored LED indicator on the sensor momentarily flashes green after release of the DELAYS push-button to acknowledge the delay time has been set into the nonvolatile memory of the sensor.

### Resetting Delay Times

Place Switch 4 in the D-OFF position and press the DELAYS push-button two successive times for resetting the OFF delay time to the minimum response time. Perform the same process with Switch 4 in the D-ON position for resetting the ON delay time to the minimum response time. The multicolored LED indicator on the sensor momentarily flashes amber after the second release of the DELAYS push-button to acknowledge the delay time has been reset to the minimum response time.

### Sensor Limits Setup Push-button

First, during installation, make sure the sensor face is as parallel as possible to the surface of the material being detected.

To set the limits, simply place an object at the desired distance from the sensor for one limit and press the LIMITS push-button once. This sets the first limit and switches the sensor output to an inactive state during the limit setup. While the LIMITS push-button is depressed, the multicolored LED, located on top of the sensor, is amber. Upon release of the push-button, the LED flashes amber indicating that the second limit needs to be set within 30 seconds. Place an object at the desired position for the second limit and press the LIMITS push-button once. Again, while the push-button is depressed, the LED is amber. Upon release of the push-button, the LED flashes amber momentarily and then turns green to indicate acceptance of both limits. If 30 seconds elapse before the second limit is set, the limits revert back to the previous settings.

At the same time, the sensor output switches from the inactive to the active state, placing the sensor into the operational mode, ready to use. When power is off or interrupted, the limits are retained in a nonvolatile memory.

If in setting either limit the echo from the object is too weak or distorted, the LED flashes RED for 10 seconds (or until the button is pressed again) indicating the limit setting was not accepted by the sensor. Attempt to set both limits again, being careful to keep the object surface

parallel to the face of the sensor.

Minimum allowed distance between any two setup limits is 13 mm (1/2"). The multicolored LED flashes RED after the press and release of the LIMITS push-button for the second limit setting if the distance between the limit settings is less than 13 mm. The multicolored LED continues flashing RED either until the LIMITS push-button is pressed and released once for the first limit setting or until 10 seconds have elapsed. Pressing and releasing the LIMITS push-button once reinitiates the limit setup sequence. If 30 seconds elapse before the LIMITS push-button is pressed and released for the second limit setup, the limits revert back to the previous settings.

A special feature provides an automatic 13 mm (1/2") window limits setup function. Simply place an object within the sensing range of the sensor and press the LIMITS push-button twice in succession without moving the object. A limit is set on a line 1/4" in front and back of the object surface nearest the sensor.

### Multicolored LED Indicator During Limit Setup

Prior to pressing LIMITS push-button

- Off - Sensing no object or object is outside the sensing range
- Red - Sensing an object outside the set limits
- Green - Sensing an object inside the set limits

LIMITS push-button depressed for first time

- Amber - Sensing a good object surface condition
- Red - Sensing no object or a poor object surface condition

LIMITS push-button released for first time

- Flashing Amber - First limit accepted, waiting for second limit
- Flashing Red - First limit not accepted; retry setting limit

LIMITS push-button depressed for second time

- Amber - Sensing a good object surface condition
- Red - Sensing no object or a poor object surface condition

LIMITS push-button released for second time

- Green or Red - Second limit accepted
- Green or Amber - Second limit accepted
- Flashing Red - Second limit not accepted; retry setting both limits

### Multicolored LED Indicator in Operational Mode

- Off - Sensing no object or object is outside the sensing range
- Red - Sensing an object outside the set limits
- Green - Sensing an object inside the set limits

### Red LED Indicator in Operational Mode

The red LED serves as a visual indicator for the sensor output. The LED is illuminated when the output is in an active (ON) state. Note: Indicator is not provided on all models.

### Electrical Wiring

Sensor wires must be run in conduit free of any AC power or control wires.

#### Sensor Wire Colors

DC Models	Cable Style	Connector Style
+12 to 24 VDC	RED	BROWN
NPN/Sinking Output	WHITE	BLACK
PNP/Sourcing Output	GREEN	WHITE
Common	BLACK	BLUE

#### AC Models\*

100 to 240 VAC	BROWN	BROWN
Switch Line Side	BLACK	BLACK
Switch Load Side	WHITE	WHITE
Neutral	RED	BLUE

#### \*WARNING

All cables are not alike. Verify that connector pin outs and cable conductor colors match up with the wiring illustrations shown in the operating instructions.

### View of Plug on Connector Style Sensor

#### DC Power Models

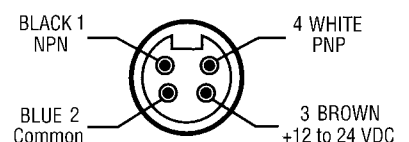

#### AC Power Models

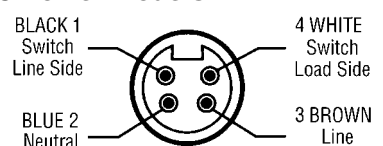

## Outputs

### DC Cable Models

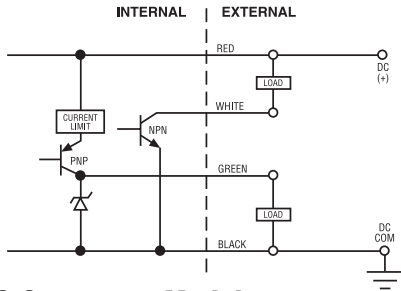

### DC Connector Models

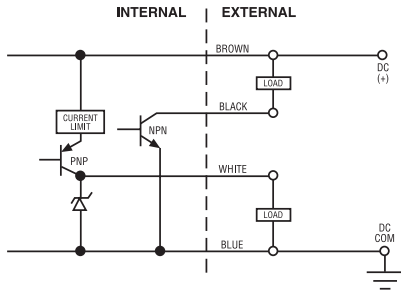

### AC Cable Models

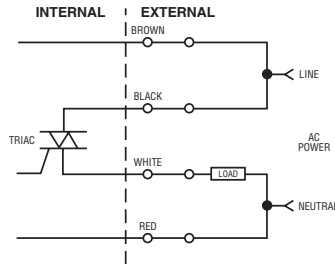

### AC Connector Models

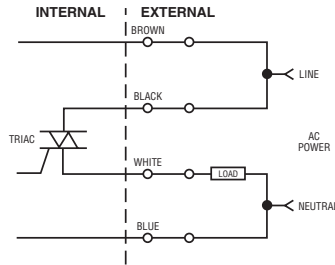

## Sensor Wire Connections

### DC Models

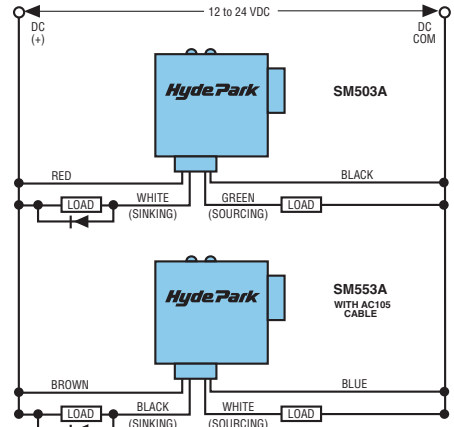

### AC Models

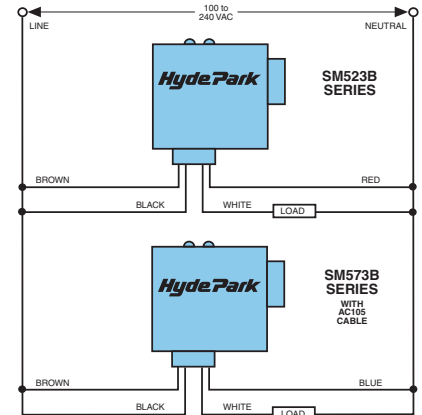

## Dimensions

### Cable Model

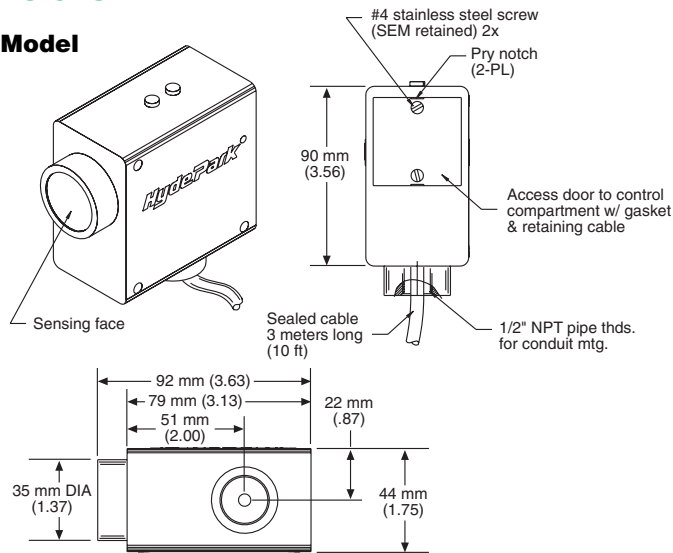

### Connector Model

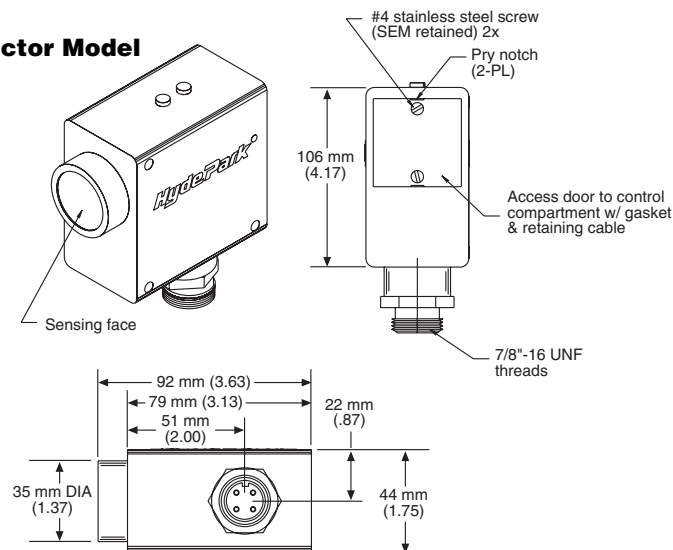

### Remote Sensing Models

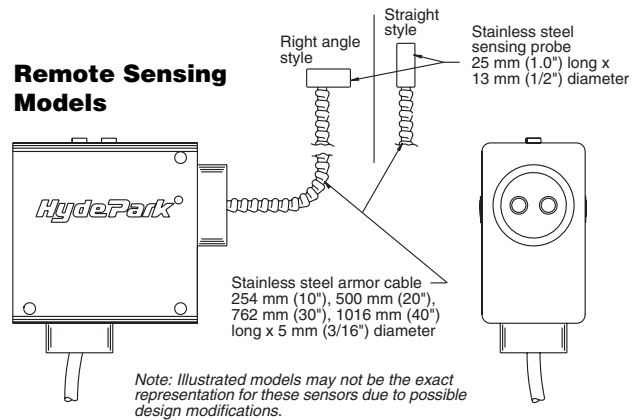

## Mounting Accessories

### AC230

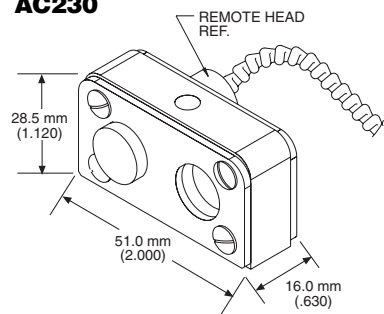

## Mounting Accessories

### AC213

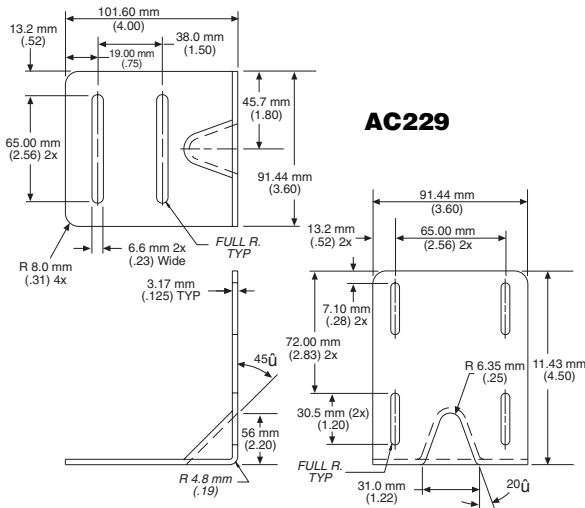
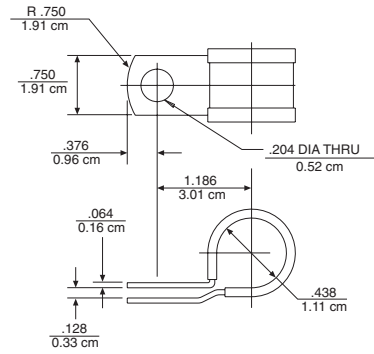

### AC222

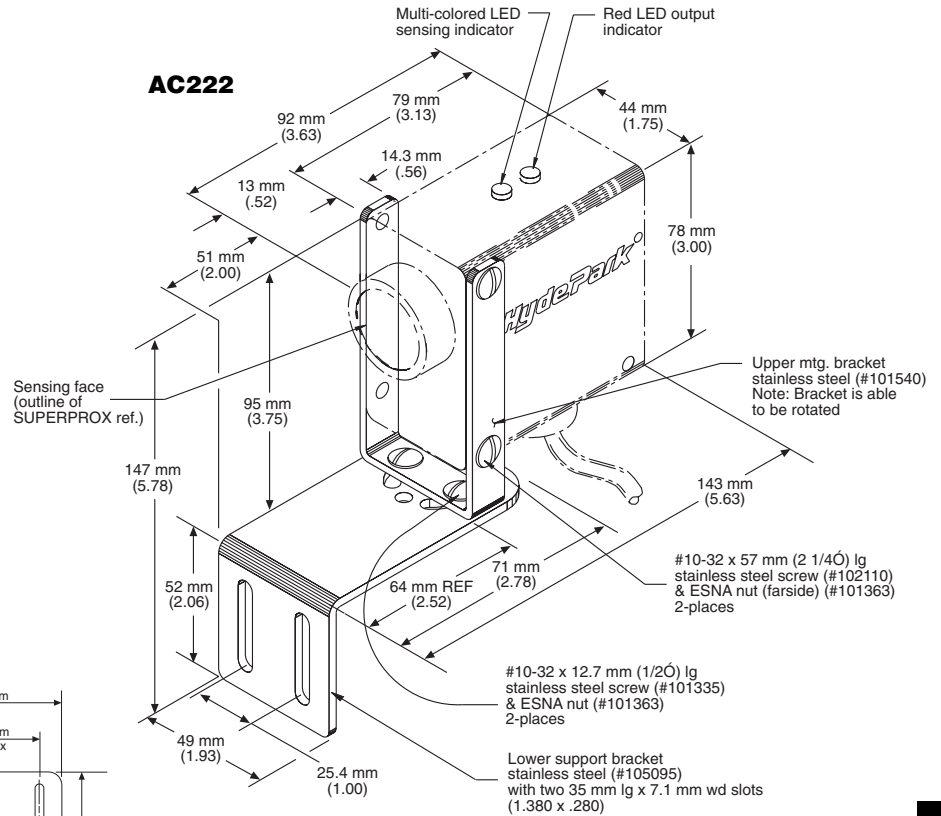

## General Specifications

### Sensing

Ranges:  
51 to 1 m (2 to 39")  
120 mm to 2 m (4.7 to 79") - DC Models only  
Sonic Frequency: 200 kHz

### Power Requirements

DC Models:  
12 to 24 VDC  $\pm$  10% @ 80 mA, 2 W max.,  
excluding output load (regulated supply)  
AC Models:  
100 to 240 VAC, 50/60 Hz, @ 30 mA, 7.5 VA  
max., excluding load

### Outputs

DC Models:  
NPN Sinking: Switch selectable N.O./N.C.  
Sinking on-state voltage drop:  
Maximum 0.25 volts @ 60 mA  
Sinking load current:  
Maximum 100 mA  
Sinking output voltage:  
Maximum applied 30 VDC  
PNP Sourcing: Switch selectable N.O./N.C.  
Sourcing output current:  
Maximum 100 mA  
Current limit protected to less than 160 mA  
AC Models:  
TRIAC, switch selectable N.O./N.C.  
Maximum continuous load current: 1 Amp  
Maximum applied output voltage: 260 VAC  
Maximum off-state leakage current: less than  
50  $\mu$ A (100% PLC/AC input interface compatibility)

### Response Time

"On" 10 ms, "Off" 10 ms to  
"On" 30 ms, "Off" 30 ms, depending  
upon model

### Indicators

Multicolored (Amber, Red, Green) LED:  
Indicates limits setup and operational modes  
Red LED: Visual indicator for sensor output;  
Illuminated when output is in an active (on) state

### Connections

Cable Style Models:  
DC: 24 AWG, PVC jacket,  
4-conductor, 3 meters (10') long, standard  
AC: 20 AWG, PVC jacket,  
4-conductor, 3 meters (10') long, standard  
Connector Style Models:  
DC: 4-pin "mini" style  
AC: 4-pin "mini" style

### Protection

Power Supply: current-limited over-voltage, ESD,  
reverse polarity, fused on AC model  
Outputs: current-limited over voltage, ESD,  
over-current, fused TRIAC on AC model

### Environmental

Operating Temperature Range:  
0° to 50°C (32°F to 122°F)  
Storage Temperature Range: -40°C to 100°C  
(-40° to 212°F)  
Operating Humidity: 100%  
Protection Ratings: NEMA 4X, IP67  
Chemical Resistance: Resists most acids and  
bases, including most food products.  
Fluorosilicone transducer face is available to  
provide resistance to aromatic and petroleum-  
based hydrocarbons.

### Agency Approvals

CE Mark: CE conformity is declared to:  
EN61010-1: 1990 including amend. No. 1:1992  
EN55011 Group 1 Class A, EN50082-1.

Declaration of conformity available upon  
request

AC Models SM520/570 carry the ETL safety label.

### Construction

Dimensions (overall)  
92 mm (3.625") L x 44 mm (1.75") W x 91 mm  
(3.58") H  
Housing:  
Case: ULTEM®\* (FDA approved)  
Optional: NORLYL® (USDA-Dairy 3A  
Sanitary Standards compliant)  
Transducer Face: Silicone rubber (FDA approved)  
Optional: Fluorosilicone rubber  
Sensor Cable: PVC jacket  
LED: Polycarbonate

\* ULTEM® and NORLYL® are registered trademarks of The  
General Electric Co.

## Accessories

- Model AC105**, Straight, 7/8-16 mini, 4-conductor,  
mating connector cable, 4 m (12'), for connector-  
style sensors
- Model AC105-50**, Straight, 7/8-16 mini, 4-conductor,  
mating connector cable, 15 m (50'), for connector-  
style sensors
- Model AC213**, Stainless and Teflon, remote sensing  
probe mounting bracket
- Model AC222**, Standard, stainless mounting bracket  
assembly, slotted for vertical adjustment
- Model AC229**, Stainless, plate-style, right-angle,  
mounting bracket, with base slotted for forward/  
reverse adjustment and side slotted for sensor  
adjustment
- Model AC230**, Three-piece, stainless, mounting  
bracket assembly with O-ring mount for sensor  
models with remote heads.

See page 7-1 for accessory photos.

# Selection Chart

## SM503 Series Proximity with Delay On/Off Control

Model No.	Power		Version		Connection		Sensing Range			Transducer Style		Materials			Default Window	Special Delay	Notes	Special Features
	100-240 VAC	12-24 VDC	Cable	Connector	2 m (79')	1 m (39')	635mm (25')	Standard	Rt. Angle	Remote	Silicone*	ULTEM®*	NORYL®*	Special Delay				
SM503A-000•			■	■				■	■				■	■				
SM503A-000 AA			■	■				■	■				■	■				Remote limit setup
SM503A-025 AA			■	■									■	■		+0.1"/-0.25"		Remote limit setup
SM503A-025 R2			■	■						■ (20°)			■	■		+0.1"/-0.25"		
SM503A-100•			■	■									■	■				
SM503A-100 AA			■	■									■	■				Remote limit setup
SM503A-100 R2			■	■						■ (20°)			■	■				
SM503A-100 S4			■	■							■ (40°)		■	■				
SM503A-400			■	■									■	■				
SM503A-415			■	■									■	■		±1"		
SM523B-000•	■		■	■									■	■				
SM523B-000 R2	■		■	■						■ (20°)			■	■				
SM523B-000 R4	■		■	■						■ (40°)			■	■				
SM523B-017	■		■	■									■	■			250ms incr.	
SM523B-049	■		■	■									■	■			5ms incr.	
SM523B-100•	■		■	■									■	■				
SM523B-100 R2	■		■	■						■ (20°)			■	■				
SM523B-100 R4	■		■	■						■ (40°)			■	■				
SM523B-100 S2	■		■	■							■ (20°)		■	■				
SM523B-100 S3	■		■	■							■ (30°)		■	■				
SM523B-100 S4	■		■	■							■ (40°)		■	■				
SM523B-117	■		■	■									■	■			250ms incr.	
SM553A-000•			■	■									■	■				
SM553A-044			■	■									■	■		±0.1"		
SM553A-091			■	■									■	■		±0.05"		
SM553A-100•			■	■									■	■				
SM553A-117			■	■									■	■			250ms incr.	
SM553A-144			■	■									■	■		±0.1"		
SM553A-400			■	■	■								■	■				
SM573B-000•	■		■	■									■	■				
SM573B-000 R2	■		■	■						■ (20°)			■	■				
SM573B-000 S3	■		■	■							■ (30°)		■	■				
SM573B-000 S4	■		■	■							■ (40°)		■	■				
SM573B-017	■		■	■									■	■			250ms incr.	
SM573B-044	■		■	■									■	■		±0.1"		
SM573B-091	■		■	■									■	■			5 ms incr.	
SM573B-100•	■		■	■									■	■				
SM573B-115	■		■	■									■	■		±1"		
SM573B-144	■		■	■									■	■		±0.1"		

• = Most commonly stocked sensors

\* = See definition in *Sensing Terms*.

Fluorsilicone available at additional cost.

All possible sensor configurations are not listed here.

## Model SM504 Series



CE



Sensing full or empty case conditions are greatly simplified with these SUPERPROX® sensor models. Other typical applications include sensing height differentiation, detecting object surfaces in specific areas, and performing on-demand and automation-control sensing functions.

The SUPERPROX® Model SM504B (cable style) and Model SM554B (connector style) series of ultrasonic, proximity sensors, when used in a set, provide for external control of the pulsing of all the sensors. A setup switch in these sensors, designated

“Master” and “Slave,” selects the operating technique to either simultaneously synchronize or gate the transmit and receive cycles of a multiple sensor set. This unique concept is an effective solution for applications such as: full or empty case inspecting, on-demand controlled sensing or inspecting, in-case container counting, automation control sensing, object-in-area sensing, down container sensing, differential height inspecting, and more.

The synchronized technique is designed for applications requiring continuous “curtain” sensing over a wide area. Synchronized sensing allows any number of sensors to be operating close together, thus eliminating any possible adverse ultrasonic signal interference between the sensors.

Controlled or multiplexed sensing of multiple objects, locations or surfaces is accomplished using the gated technique. With this technique, PLS and PLC output switches or other sensing devices may be used to trigger or gate a sensor set. Depending on the applications, a set of these sensors is used with an isolated switching device to prevent possible false sensor outputs due to changing foreground object conditions.

### SUPERPROX® Ultrasonic Proximity Sensors

### Synchronized/ Gate-controlled Sensing

- Allows sensors to operate in close proximity
- Detects objects at specific points within adjustable “window” limits
- Makes profiling and positioning applications possible
- A push-button sets window limits
- Operating range up to 2 m (79”)
- CE certified

Like other SUPERPROX® sensors, these models have the capability to detect objects at specific points within adjustable “window” limits, thus making profiling and positioning applications possible. A push-button sets the window limits. The sensors carry the CE Mark and are epoxy sealed in a tough plastic housing to resist harsh, wet, or dirty environments typically associated with the above applications. The housing meets NEMA 4X and IP67 industry standards. A Dairy 3A compliant housing is available as an option. These sensors have operating ranges of 51 to 635 mm (2 to 25”), 51 to 1 m (2 to 39”) and 120 mm to 2 m (4.7 to 79”) and are available in 12 to 24 VDC model versions.

SUPERPROX® SM504  
SERIES

## Control Compartment

A unique feature available to the user of these sensors is the ability to quickly set up each sensor for a specific application. The sensor is configured through four slide switches and a push-button (See Figure 1) located inside a water-tight control compartment on the

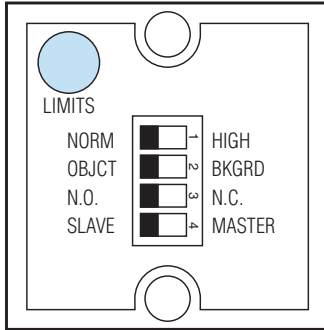

Figure 1

sensor. To access the controls, remove the small square cover on the back of the sensor. Simply loosen the two flathead cover screws and insert a small-blade screwdriver in either the top or bottom slot to remove the cover. A short plastic tether prevents separation of the cover from the sensor. NOTE: The switch settings may require changing for the intended application.

## Sensor Configuration Switches

**Switch 1** configures the sensor to operate in either a normal or high sensitivity mode. Place this switch in the NORM position for sensing liquid or solid materials. Place the switch in the HIGH position for sensing soft or porous materials that will absorb some of the ultrasonic energy.

**Switch 2** configures the sensor to operate in either an object or background sensing mode. Place this switch in the OBJCT position to perform a sensing function for receiving the reflected ultrasonic energy directly off an object. Place this switch in the BKGRD position to perform a break-beam sensing function for receiving the reflected ultrasonic energy directly off a fixed background target.

**Switch 3** selects the operating mode for the sensor output to be either normally open (N.O.) or normally closed (N.C.).

**Switch 4** configures the sensor to perform either a slave or master operating function. See Synchronized Sensing and Gate-controlled Sensing descriptions for selecting the proper switch position.

## Synchronized Sensing

Synchronized sensing is a unique feature of this sensor that enables reliable “curtain” sensing or inspecting over a wide area by using multiple sensors in a set. Synchronized sensing allows these sensors to be operated close together, thus eliminating any possible adverse ultrasonic signal interference between the sensors.

Any number of these sensors can be operated together to perform a synchronized sensing function. It is accomplished by simply connecting together the external control wire lead from all the sensors in the set as shown in the illustration on the next page. One of the connected sensors must operate with setup Switch 4 in the “Master” position and the other connected sensors must operate with setup Switch 4 in the “Slave” position. The designated “Master” sensor continuously synchronizes the transmit and receive cycles of all the connected sensors as a result of this configuration.

## Model Reference Guide - SM504 Series

Use the guide below to ensure the correct model number is specified for the application. Please note that not all sensor model combinations are available.

### EXAMPLE MODEL:

**SM5 5 4 B - 4 00 - AF**

### SUPERPROX® Product Series

#### Power/Connection Type (DC only)

- 0...12 to 24 VDC / cable style
- 5...12 to 24 VDC / connector style

#### Sensing Function

- 4...Proximity - Synchronized/Gate-controlled

#### Design Level

- A...Applies to discontinued models with NPN sinking output only
- B...Applies to models with NPN sinking and PNP sourcing outputs

#### Sensing Range

- 0...51 to 635 mm (2 to 25")
- 1...51 to 1 m (2 to 39")
- 4...120 mm to 2 m (4.7 to 79")

#### Functionality

- 00...Standard Proximity
- 05...Default Window: ±0.5"
- 44...Default Window: ±0.1"
- 67...Switch selectable, 1 or 2 echo hit recognition with high gain

#### Special Features

- ... No letter indicates standard sensor with no special features
- FS... Fluorosilicone transducer face
- AA... Remote limit setup (Available on cable models only.)
- AB... RS232, 4-digit/2-decimal place output (Available on cable models only.)
- AD... Limits push-button disabled
- AE... RS232, 5-digit/3-decimal place output (Available on cable models only.)
- AF... No LEDs

#### Housing Types

- ...No letter indicates standard ULTEM® plastic housing
- N...NORYL® Dairy 3A gray plastic housing

#### Remote Type

- ... No letter indicates standard housing
- R...Right-angle sensing head with armor cable
- S...Straight sensing head with armor cable

#### Remote Cable Length

- ... No letter indicates standard housing
  - 1...254 mm (10")
  - 2...508 mm (20")
  - 3...762 mm (30")
  - 4...1016 mm (40")
  - 5P...1270 mm (50")
  - 6P...1524 mm (60")
- Armored (standard) or PVC cable (specify P after number) Available in PVC cable only

\* ULTEM® and NORYL® are registered trademarks of The General Electric Company.



## Gate-controlled Sensing

Gate-controlled sensing is another unique feature that enables this sensor to perform periodic sensing of multiple objects or locations. Depending on the application, one or a set of these sensors is used with an isolated switching device for preventing possible false sensor outputs due to changing foreground object conditions. Devices such as SUPERPROX® sensors, programmable limit switches or other proximity sensor switches with an open-collector, current sinking output are typically used to perform the isolated gate-switch or "Master" sensor function.

Gate-controlled sensing is accomplished by connecting the external control wire lead from each sensor to the DC supply voltage common through the isolated switch as shown in the illustration on this page. Each connected sensor must operate with setup Switch 4 in the "Slave" position. In this configuration, the sensors simultaneously transmit and receive ultrasonic energy only when the gate device is switched to the ON or CLOSED state. When the gate device is switched back to the OFF or OPEN state, the sensor outputs are latched from changing state until the next gate-switch cycle.

## Sensor Limits Setup Push-button

First, during installation, make sure the sensor face is as parallel as possible to the surface of the material being detected.

To set the limits, simply place an object at the desired distance from the sensor for one limit and press the LIMITS push-button once. This sets the first limit and switches the sensor output to an inactive state during the limit setup. While the LIMITS push-button is depressed, the multicolored LED, located on top of the sensor, is amber. Upon release of the push-button, the LED flashes amber indicating that the second limit needs to be set within 30 seconds. Place an object at the desired position for the second limit and press the LIMITS push-button once. Again while the push-button is depressed, the LED is amber. Upon release of the push-button, the LED flashes amber momentarily and then turns green to indicate acceptance of both limits. If 30 seconds elapse before the second limit is set, the limits revert back to the previous settings.

At the same time, the sensor output switches from the inactive to the active state, placing the sensor into the

operational mode, ready to use. When power is off or interrupted, the limits are retained in a nonvolatile memory.

If in setting either limit the echo from the object is too weak or distorted, the LED flashes RED for 10 seconds (or until the button is pressed again) indicating the limit setting was not accepted by the sensor. Attempt to set both limits again, being careful to keep the object surface parallel to the face of the sensor.

Minimum allowed distance between any two setup limits is 13 mm (1/2"). The multicolored LED flashes RED after the press and release of the LIMITS push-button for the second limit setting if the distance between the limit settings is less than 13 mm. The multicolored LED continues flashing RED either until the LIMITS push-button is pressed and released once for the first limit setting or until 10 seconds have elapsed. Pressing and releasing the LIMITS push-button once reinitiates the limit setup sequence. If 10 seconds elapse before the LIMITS push-button is pressed and released for the second limit setup, the limits revert back to the previous settings.

A special feature provides an automatic 13 mm (1/2") window limits setup function. Simply place an object within the sensing range of the sensor and press the LIMITS push-button twice in succession without moving the object. A limit is set on a line 1/4" in front and back of the object surface nearest the sensor.

## Multicolored LED Indicator During Limit Setup

Prior to pressing LIMITS push-button:

- Off - Sensing no object or object is outside of the sensing range
- Red - Sensing an object outside the set limits
- Green - Sensing an object inside the set limits

LIMITS push-button depressed for first time:

- Amber - sensing a good object surface condition
- Red - Sensing no object or a poor object surface condition

LIMITS push-button released for first time:

- Flashing Amber - First limit accepted, waiting for second limit

- Flashing Red - First limit not accepted; retry setting limit

LIMITS push-button depressed for second time:

- Amber - Sensing a good object surface condition
- Red - Sensing no object or a poor object surface condition

LIMITS push-button released for second time:

- Green or Red - Second limit accepted
- Green or Amber - Second limit accepted
- Flashing Red - Second limit not accepted; retry setting both limits

## Multicolored LED Indicator in Operational Mode

- Off - Sensing no object or object is outside the sensing range
- Red - Sensing an object outside the set limit
- Green - Sensing an object inside the set limit

## Red LED Indicator in Operational Mode

The red LED serves as a visual indicator for the sensor output. The LED is illuminated when the output is in an active (ON) state. Note: Indicator is not provided on all models.

## Electrical Wiring

Sensor wires must be run in conduit free of any AC power or control wires.

### Sensor Wire colors

	Cable Style	Connector Style
(+)12 to 24 VDC	RED	BROWN
NPN/Sinking Output	WHITE	BLACK
PNP/Sourcing Output	BROWN	WHITE
Sync/Gate Control	GREEN	ORANGE
DC Common	BLACK	BLUE

## View of Plug on Connector Style Sensor

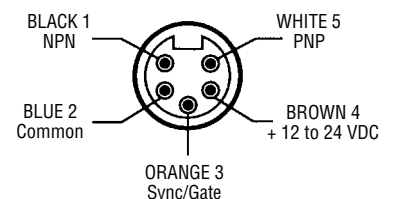

## Outputs

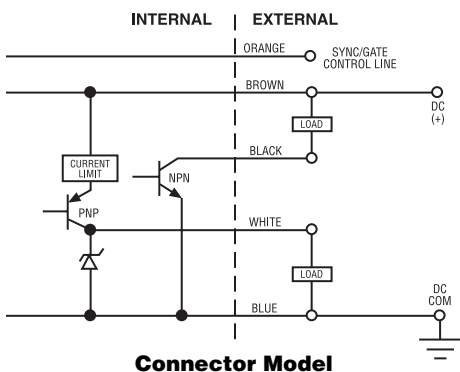
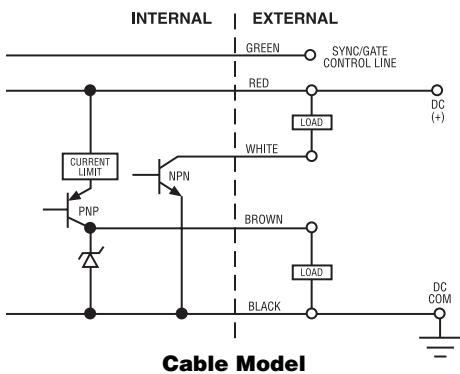

## Synchronized Sensing Connections

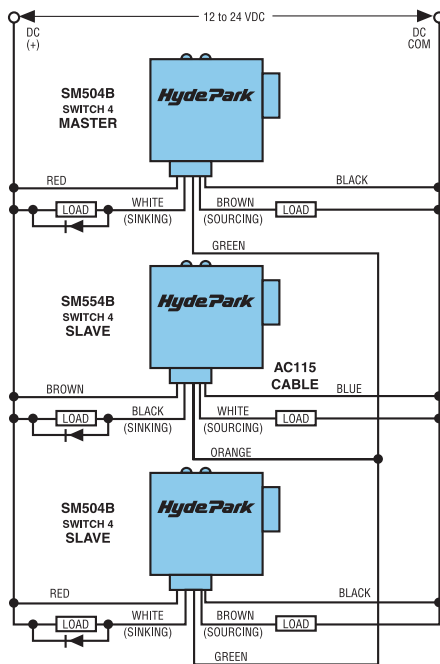

## Gate-controlled Sensing Connections

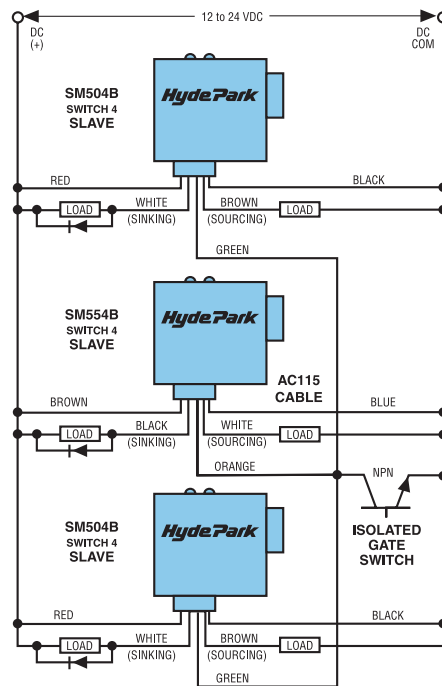

## Dimensions

### Cable Model

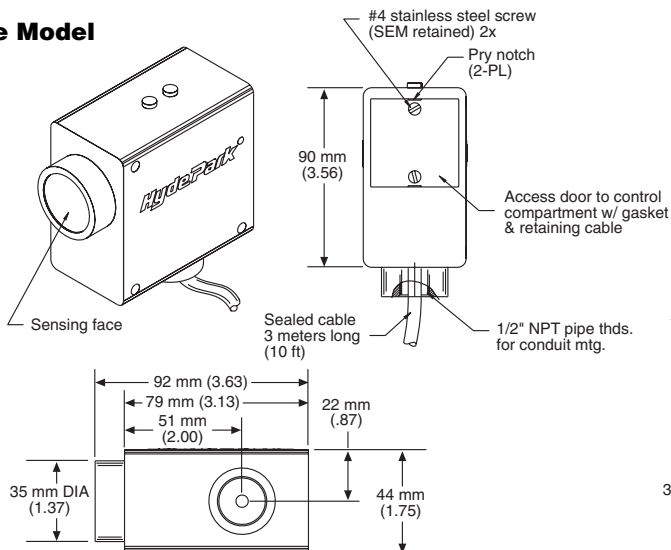

### Connector Model

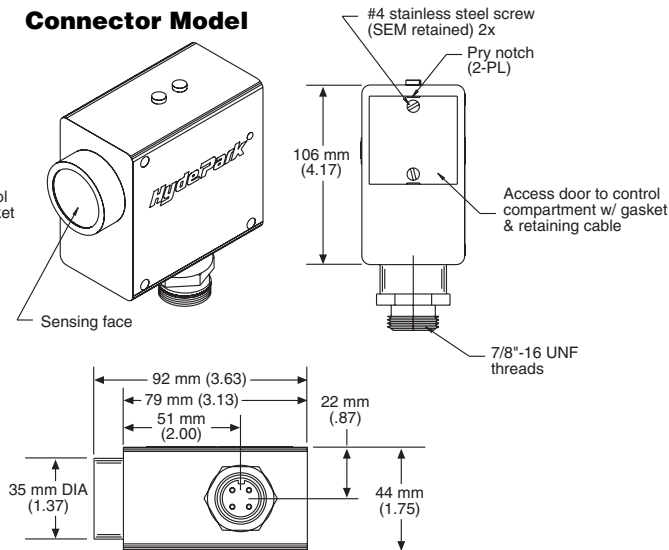

## Remote Sensing Models

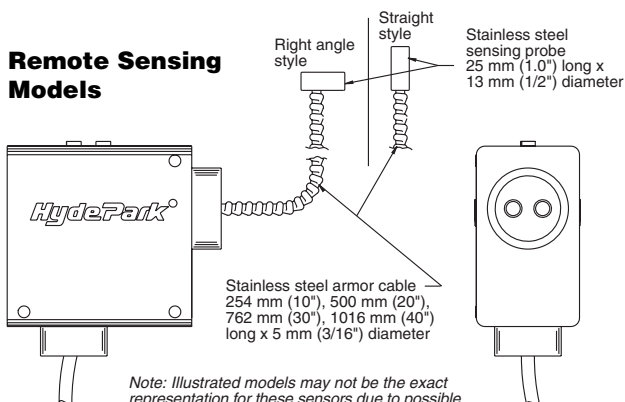

## Mounting Accessories

### AC230

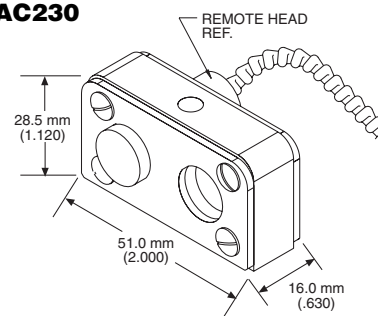

## Mounting Accessories

### AC213

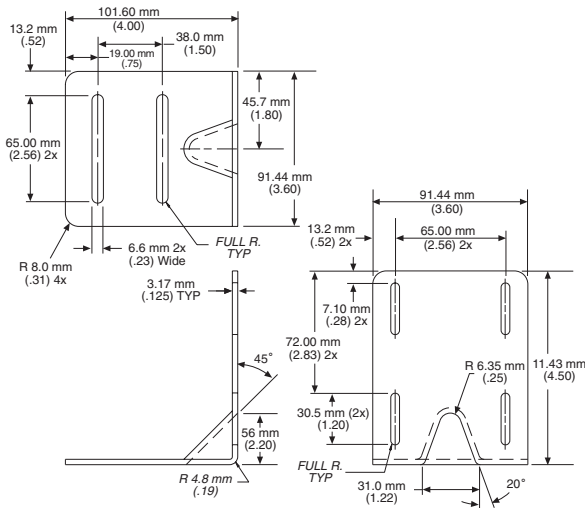
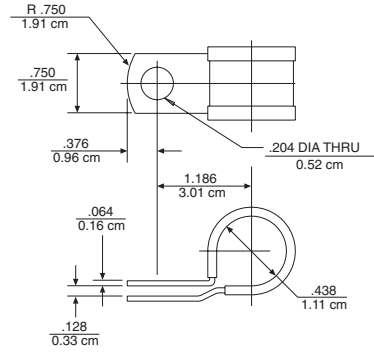

## General Specifications

### Sensing

Ranges:  
51 to 1 m (2 to 39')  
120 mm to 2 m (4.7 to 79' - DC Model only)  
Sonic Frequency: 200 kHz

### Power Requirements

DC Models:  
12 to 24 VDC  $\pm$  10% @ 80 mA, 2 W max.,  
excluding output load (regulated supply)

### Output/Input

DC Models:  
NPN Sinking: Switch selectable N.O./N.C.  
Sinking on-state voltage drop:  
Maximum 0.25 volts @ 60 mA  
Sinking load current:  
Maximum 100 mA  
Sinking output voltage:  
Maximum applied 30 VDC  
PNP Sourcing: Switch selectable N.O./N.C.  
Sourcing output current:  
Maximum 100 mA  
Current limit protected to less than 160 mA

### Input:

Input voltage range: 0 to 30 VDC  
Vin-high, minimum: 2.5 V  
Vin-low, maximum: 1.4 V  
Input current maximum: 0.76 mA

### Response Time

"On" 10 ms, "Off" 10 ms to "On" 30 ms,  
"Off" 30 ms, depending upon model

### AC222

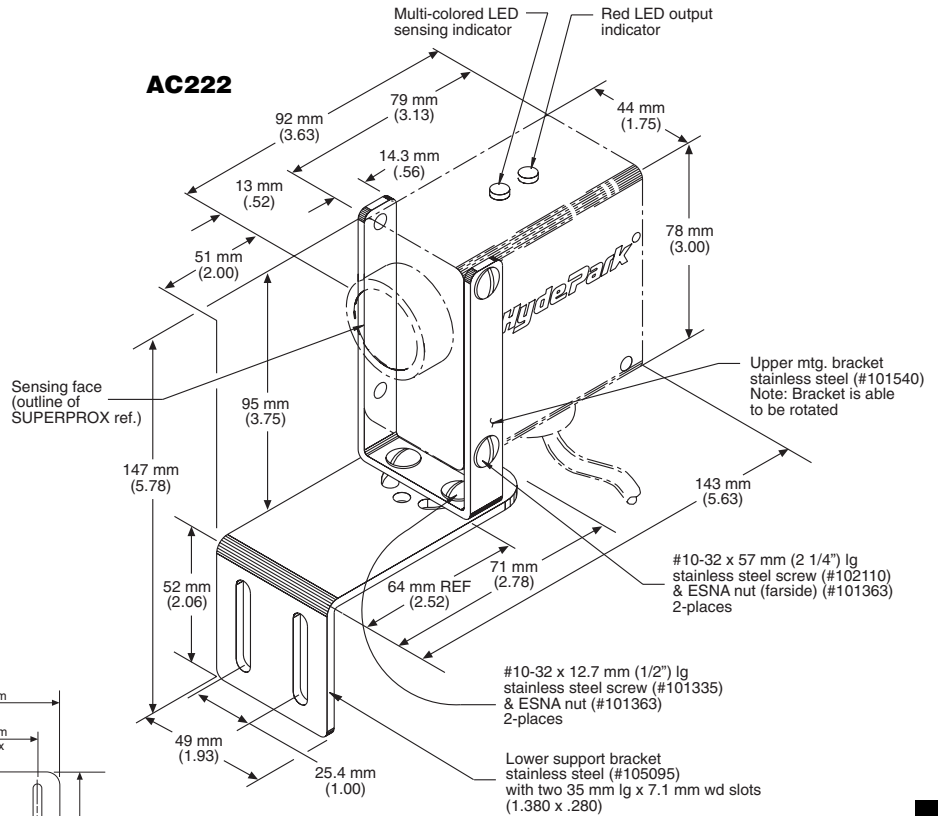

### Indicators

Multicolored (Amber, Red, Green)  
LED: Indicates limits setup and operational modes  
Red LED: Visual indicator for sensor output; illuminated when output is in an active (On) state.

### Connections

Cable Style Models:  
DC: 24 AWG, PVC jacket,  
5-conductor, 3 meters (10') long, standard  
Connector Style Models:  
DC: 5-pin "mini" style

### Protection

Power Supply: current-limited over-voltage, ESD,  
reverse polarity  
Outputs, Input: current-limited over voltage, ESD,  
over-current.

### Environmental

Operating Temperature Range:  
0° to 50°C (32° to 122°F)  
Storage Temperature Range: -40° to 100°C  
(-40° to 212°F)  
Operating Humidity: 100%  
Protection Ratings: NEMA 4X, IP67  
Chemical Resistance: Resists most acids and  
bases, including most food products.  
Fluorosilicone transducer face is available to  
provide resistance to aromatic and petroleum-  
based hydrocarbons.

### Agency Approvals

CE Mark: CE conformity is declared to:  
EN61010-1: 1990 including amend. No.1:1992  
EN55011 Group 1 Class A, EN50082-1.  
Declaration of conformity available upon request.  
AC Models SM520/570 carry the ETL safety label.

### Construction

Dimensions (overall)  
92 mm (3.625") L x 44 mm (1.75") W  
x 91 mm (3.58") H  
Housing:  
Case: ULTEM®\* (FDA approved)  
Optional: NORYL®\* (USDA-Dairy 3A  
Sanitary Standards compliant)  
Transducer Face: Silicone rubber (FDA ap-  
proved)  
Optional: Fluorosilicone rubber  
Sensor Cable: PVC jacket  
LED: Polycarbonate

\* ULTEM® and NORYL® are registered trademarks of The General Electric Co.

## Accessories

- Model AC115**, Straight, 7/8-16 mini, 5-conductor, mating connector cable, 4 m (12'), for Model SM554B-XXX series connector-style prox sensors with alarms
- Model AC115-50**, Straight, 7/8-16 mini, 5-conductor, mating connector cable, 15 m (50'), for Model SM554B-XXX series connector-style prox sensors with alarms
- Model AC213**, Stainless and Teflon, remote sensing probe mounting bracket
- Model AC222**, Standard, stainless mounting bracket assembly, slotted for vertical adjustment
- Model AC226**, Stainless and polyamide conveyor-rail clamp/bracket set
- Model AC229**, Stainless, plate-style, right-angle, mounting bracket, with base slotted for forward/reverse adjustment and side slotted for sensor adjustment
- Model AC230**, Three-piece, stainless, mounting bracket assembly with O-ring mount for sensor models with remote heads.

See page 7-1 for accessory photos.

# Selection Chart

## SM504 Series Proximity Synchronized & Gate-controlled Sensing

Model No.	Power Version		Cable Connection Style	Sensing Range			Rt. Angle	Remote Transducer Style	Transducer Materials				Default Window	Notes	Special Features
	12-24 VDC	Connector		2m(79")	1 m (39")	635mm (25")			Standard	Silicone*	Fluorosilicone*	ULTEM®*			
SM504B-000•	■	■			■	■			■		■				
SM504B-000 AA	■	■			■	■			■		■			Remote limit setup	
SM504B-005 AA	■	■							■		■	±0.5"		Remote limit setup	
SM504B-067	■	■			■	■			■		■			Switch selectable, 1 or 2 echo, hit recognition with high gain	
SM504B-100•	■	■			■	■			■		■				
SM504B-100 R3	■	■			■		■ (30")		■		■				
SM554A-067	■		■			■	■		■					Switch selectable, 1 or 2 echo, hit recognition with high gain	
SM554B-000•	■		■			■			■		■				
SM554B-000 S4	■		■			■	■ (40")		■		■				
SM554B-005	■		■			■			■		■	±0.5"			
SM554B-044	■		■			■			■		■	±0.1"			
SM554B-067	■		■			■			■		■			Switch selectable, 1 or 2 echo, hit recognition with high gain	
SM554B-100•	■		■			■			■		■				
SM554B-105	■		■			■			■		■	±0.5"			
SM554B-400 AF	■		■	■		■			■		■			No LEDs	

• = Most commonly stocked sensors

\* = See definition in *Sensing Terms*.

All possible sensor configurations are not listed here.

## Model SM505 Series



### *SUPERPROX<sup>®</sup> Ultrasonic Proximity Motion Sensors*

### *Rate & Stopped Motion Sensing*

- *Easy push-button setup for the specific application*
- *Rate adjustments:  
Single file,  
30 to 1200 CPM;  
Mass wide,  
5 to 200 CPM*
- *Noncontact sensing range up to 2 m (79")*
- *SUPERPROX<sup>®</sup> housing meets NEMA 4X and IP67 industry standards*
- *CE certified*
- *AC-powered model ETL listed*



In contrast to other jam and gap-type sensors which stop machine processes upon sensing a back-to-back, no-gap condition, this SUPERPROX<sup>®</sup> microprocessor-based series (Model SM505 through Model SM575) of ultrasonic motion sensors is rate sensitive. Even with a back-to-back, no-gap condition, the operator can, through the use of a rate potentiometer, set the speed below which the output switches off,

causing the particular machine under control to stop. Another potentiometer enables the operator to set the time delay desired to restart the particular machine under control once the resumed container speed is at or above the set rate. This time delay feature prevents the output from switching on prematurely when the container movement is momentarily at or above the set rate.

Available in either AC or DC models, these self-contained sensors can be positioned throughout the packaging line and easily configured to automatically control the synchronized starting and stopping of conveyor lines and the starting and stopping of the machines in the system. By allowing the machines to run longer before shutdown due to a line backup, and to start earlier once the movement begins, the result is a smoother, more efficient container handling system.

These sensors can be used in either single-file or mass-wide conveyor operations with all types of containers. As with all SUPERPROX<sup>®</sup> sensors, a simple push-button is used to set the limits within which the container

motion is monitored and detected. In single-file applications, container motion is monitored as soon as a back-to-back, no-gap condition exists. In mass-wide applications, container motion is monitored when a container moves laterally to within 8 in. of the SUPERPROX<sup>®</sup> sensor.

## Introduction

This SUPERPROX® sensor series detects the movement of either plastic, glass, or metal containers as small as 38 mm (1-1/2") in diameter on single file and mass conveyors. By using the unique "window" sensing feature with two potentiometers and a background target on the opposite side of the conveyor, a minimum or stopped container movement is reliably detected. The container pass line nearest the sensor and background target are the sensing references for respectively setting a foreground and background sensing window.

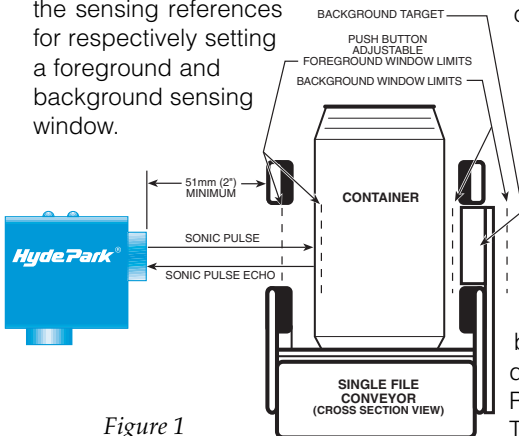

Figure 1

NOTE: Objects placed within the 51 mm near range will cause erratic operation.

## Control Compartment

A unique feature available to the user of these sensors is the facility to quickly set up each sensor for a specific motion sensing application. The sensor is configured through three slide switches, two potentiometers, and one push-button (See Figure 2) located inside a water-tight control compartment on the sensor. To access the controls, remove the small square cover on the back of the sensor. Simply loosen the two flathead cover screws and insert a

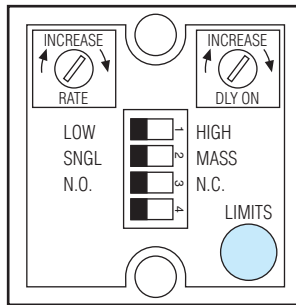

Figure 2

small-blade screwdriver in either the top or bottom slot to remove the cover. A short plastic tether prevents separation of the cover from the sensor. NOTE: The switch settings may require changing for the intended application.

## Container Motion Sensing Function

The solid state output in the SUPERPROX container motion sensors switches OFF when a back-to-back line or mass of containers is detected moving below the setting of the RATE potentiometer (See Page 4-55). The sensor output switches ON after the back-to-back line or mass of containers has been detected moving at or above the setting of the RATE potentiometer for a delay time period set by the DELAY ON potentiometer (See Page 4-55). The sensor output also switches ON should the background target on the opposite side of the conveyor be detected for the delay time period as a result of containers moving out from between the sensor and background target.

## Single-File Conveyor Sensing Mode

The maximum distance between the sensor and background target on the

opposite side of a single-file conveyor cannot exceed 254 mm (10"). The overall clearance between the container and conveyor side rails should not be more than 10 mm (3/8"). When a back-to-back line of containers is located between the background target and sensor, the sensor output switches OFF upon detecting container motion either stopped or at a minimum rate (See Figure 3).

## Mass Conveyor Sensing Mode

The maximum distance between the sensor and background target on the opposite side of a mass conveyor cannot exceed 1 m (39"). When a mass of containers is within 204 mm (8") or less from the foreground sensing window, the sensor output switches OFF upon detecting container motion either stopped or at a minimum rate (See Figure 4).

## Sensor Configuration Switches

**Switch 1** configures the sensor to operate in either a low or high sensitivity mode. Place this switch in the LOW position for sensing container motion on single file conveyors. Place the switch in the HIGH position for sensing container motion on mass conveyors.

**Switch 2** configures the sensor to detect container motion on either a single file or mass conveyor. Place this switch in the SNGL position for sensing motion on a single file conveyor over a 254 mm (10") sensing range. Place the switch in the MASS position for sensing container motion on a mass conveyor over a 1 m (39") sensing range.

**Switch 3** selects the operating mode for the sensor output to be either normally open (N.O.) or normally closed (N.C.).

**Switch 4** not used.

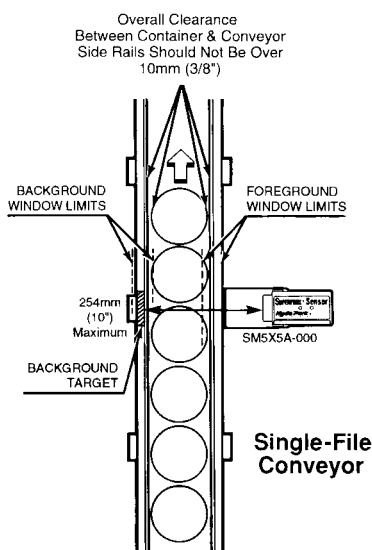

Figure 3

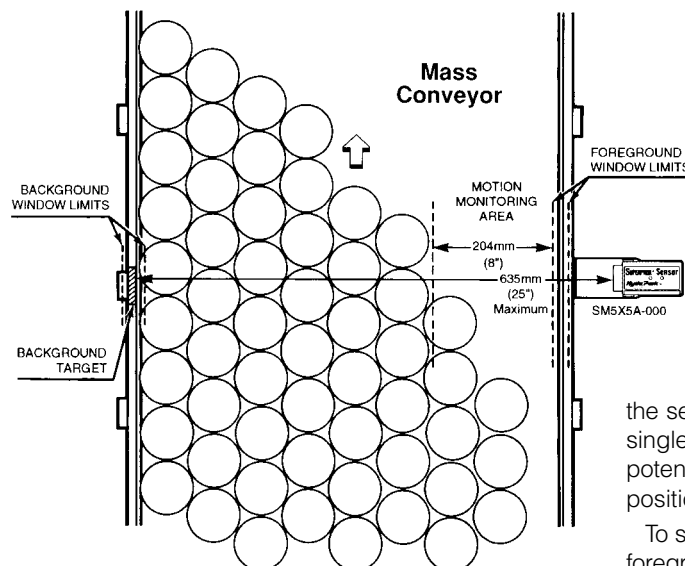

Figure 4

## Sensor Limits Setup Push-button

First, during installation, make sure the sensor face is mounted in line and as parallel as possible with the background target sensing surface on the opposite side of the conveyor.

Second, before setting the sensing window limits, adjust the single turn RATE and DELAY ON potentiometers to the fully CCW position.

To set the background and foreground sensing window limits,

simply move containers away from between the sensor and background target and press the LIMITS push-button once. This sets the background window limits and switches the sensor output OFF during the limit setup. While the LIMITS push-button is depressed, the multicolored LED located on top of the sensor, is amber. Upon release of the push-button, the LED flashes amber indicating that the foreground window limits need to be set within 30 seconds. To set the foreground window limits, place a container on the conveyor against the rail nearest to the sensor with the main body area directly in front of the sensor and press the LIMITS push-button once. Again, while the push-button is depressed, the LED is amber. Upon release of the push-button, the LED turns green indicating the background and foreground window limits have been successfully set. If 30 seconds elapse before the foreground window limits are set, the limits revert back to the previous settings.

At the same time, the sensor output switches from OFF to ON, placing the sensor into the operational mode, ready to use. When power is off or interrupted, the limits are retained in a nonvolatile memory.

The background and foreground window limits can be set up in reverse order. To set the limits in reverse order, place a container on the conveyor against the rail nearest to the sensor with the main body area directly in front of the sensor and press the LIMITS push-button once. This sets the foreground window limits and switches the sensor output OFF during the limit setup. While the LIMITS push-button is depressed, the multicolored LED, located on top of the sensor, is amber. Upon release of the push-button, the LED flashes amber indicating that the background window limits need to be set within 30 seconds. Move containers away from between the sensor and background target and press the LIMITS push-button once. Again, while the push-button is depressed, the LED is amber. Upon release of the push-button, the LED turns red indicating the foreground and background window limits have been successfully set. At the same time, the sensor output switches from OFF to ON, making the sensor operational.

If in setting the limits the echo from either the background target or container is too weak or distorted, the LED flashes red for 10 seconds (or until the button is pressed again) indicating the limit setting was not accepted by the sensor. Attempt to set both limits again with the container and background target surfaces parallel to the face of the sensor.

## RATE Adjustment

The RATE potentiometer sets the minimum threshold rate at which the sensor output switches either OFF or ON, depending whether there is a decrease or an increase in the container motion rate. A CW rotation increases the rate setting of the single turn RATE potentiometer. The output switches OFF when containers are moving below the setting of the RATE potentiometer. The output switches ON after container movement resumes at or above the setting of the RATE potentiometer for a delay-on time period. The rate adjustment range for sensing minimum container motion on single-file or mass conveyor is determined by the Switch 2 position. With Switch 2 in the SNGL position, the rate adjustment range is 30 to 1200 CPM (See Figure 5). With Switch 2 in the MASS position, the rate adjustment range is 5 to 200 CPM (See Figure 6).

Initially, set the RATE potentiometer fully CCW to the minimum rate position. After the background and foreground sensing window limits have been set, the RATE potentiometer can be adjusted to the appropriate setting by slowly turning the potentiometer CW with containers moving at the optimum line speed in the application.

## DELAY ON Adjustment

The DELAY ON potentiometer sets the minimum delay time before the output switches from OFF to ON after container movement resumes at or above the setting of the RATE potentiometer. A CW rotation increases the delay setting of the single turn DELAY ON potentiometer. The delay-on adjustment prevents the output from switching ON prematurely when container movement resumes momentarily at or above the setting of the RATE potentiometer. The delay-on time adjustment range is .05 to 10 seconds.

## Rate Potentiometer

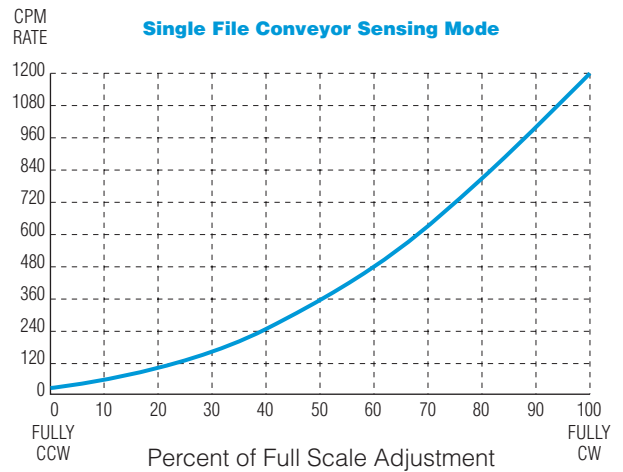

Figure 5

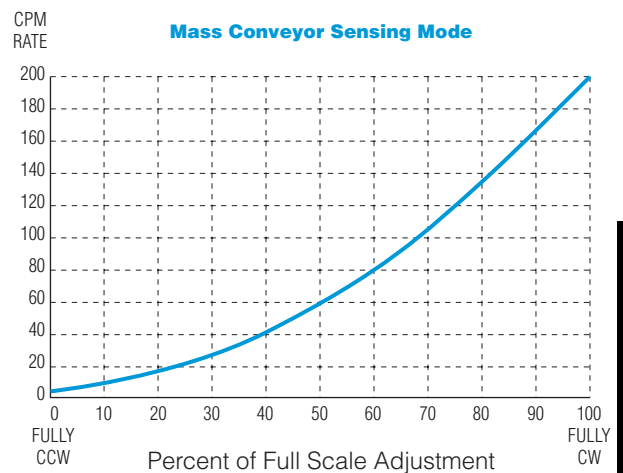

Figure 6

Initially, set the DELAY ON potentiometer fully CCW to the minimum delay-on time position. After the RATE potentiometer has been set, the delay-on time can be set at the DELAY ON potentiometer for the appropriate delay time before the sensor output switches ON in the application.

## Multicolored LED Indicator During Limit Setup

### Setting Limits For The Background 1st & Foreground 2nd

Prior to pressing LIMITS push-button for setting the background limits without containers on conveyor between the sensor and background target:

- Red or Amber - Sensing background target, ready for background limits setup.
- Off - Background target either not aligned with sensor or beyond sensing range.

Press and release LIMITS push-button:

- Flashing Amber -  
Background limits accepted; waiting for foreground limits setup within 30 seconds.
- Flashing Red -  
Background limits not accepted; verify background target aligned with sensor and within sensing range before repeating background limits setup (flashing red LED lasts for 10 seconds or until the pushbutton is pressed again).

Place a container on conveyor with the container directly in front of the sensor before pressing LIMITS push-button for setting the foreground limits.

Press and release LIMITS push-button:

- Green -  
Foreground limits accepted; sensor is ready for detecting container motion.
- Flashing Red -  
Foreground limits not accepted; verify the container is centered and parallel with sensor face (flashing red LED lasts for 10 seconds or until the push-button is pressed again). Move container away from sensor, press and release LIMITS push-button for flashing amber LED. Place the container directly in front of sensor again, press and release LIMITS push-button for green LED display.

### Setting Limits For The Fore-ground 1st & Background 2nd

Prior to pressing LIMITS push-button for setting the background limits with a container on conveyor and directly in front of the sensor:

- Green or Amber -  
Sensing container, ready for foreground limits setup.
- Off -  
not sensing container, container not centered or parallel with the sensor face.

Press and release LIMITS push-button:

- Flashing Amber -  
Foreground limits accepted, waiting for background limits setup within 30 seconds.
- Flashing Red -  
Foreground limits not accepted; verify the container is centered and parallel with sensor face before repeating foreground limits setup (flashing red LED lasts for 10 seconds or until the push-button is pressed again).

## Electrical Wiring

Sensor wires must be run in conduit free of any AC power or control wires.

### Sensor Wire Colors

#### DC Models

	Cable Style	Connector Style
(+) 12 to 24 VDC	RED	BROWN
NPN/Sinking Output	WHITE	BLACK
PNP/Sourcing Output	GREEN	WHITE
Common	BLACK	BLUE

#### AC Models\*

100 to 240 VAC	BROWN	BROWN
Switch Line Side	BLACK	BLACK
Switch Load Side	WHITE	WHITE
Neutral	RED	BLUE

## \*WARNING

All cables are not alike. Verify that connector pin outs and cable conductor colors match up with the wiring illustrations shown in the operating instructions.

### View of Plug on Connector Style Sensors

#### DC Power Models

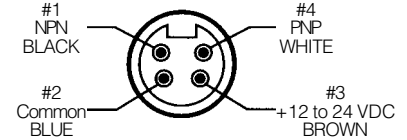

#### AC Power Models

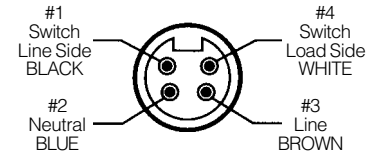

## Model Reference Guide - SM505 Series

Use the guide below to ensure the correct model number is specified for the application. Please note that not all sensor model combinations are available.

### EXAMPLE MODEL:

#### SUPERPROX® Product Series

**SM5 0 5 A - 1 00 - FS N S 3**

#### Power/Connection Type

0...12 to 24 VDC / cable style      5...12 to 24 VDC / connector style  
2...100 to 240 VAC / cable style      7...100 to 240 VAC / connector style

#### Sensing Function

5...Proximity - motion

#### Design Level

A...Applies to all DC-powered models  
B...Applies to all AC-powered models

#### Sensing Range

0...51 to 635 mm (2 to 25")  
1...51 to 1 m (2 to 39")

#### Functionality

00...Standard Proximity - motion

#### Special Features

... No letter indicates standard sensor with no special features  
FS... Fluorosilicone transducer face  
AA... Remote limit setup (available on cable models only.)  
AB... RS232, 4-digit/2-decimal place output (available on cable models only.)  
AD... Limits push-button disabled  
AE... RS232, 5-digit/3-decimal place output (Available on cable models only.)  
AF... No LEDs

#### Housing Types

...No letter indicates standard ULTEM® plastic housing  
N...NORYL® Dairy 3A gray plastic housing

#### Remote Type

... No letter indicates standard housing  
R...Right-angle sensing head with armor cable  
S...Straight sensing head with armor cable

#### Remote Cable Length

... No letter indicates standard housing  
1...254 mm (10")  
2...508 mm (20")  
3...762 mm (30")  
4...1016 mm (40")

} Armored (standard) or PVC cable (specify P after number)

5P...1270 mm (50")  
6P...1524 mm (60") Available in PVC cable only

\* ULTEM® and NORYL® are registered trademarks of The General Electric Company.



## Outputs

### DC Cable Models

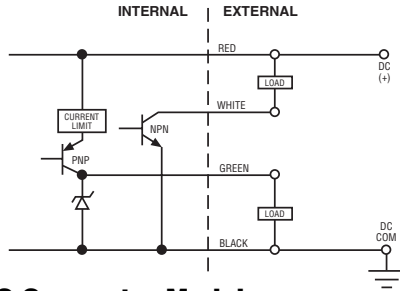

### DC Connector Models

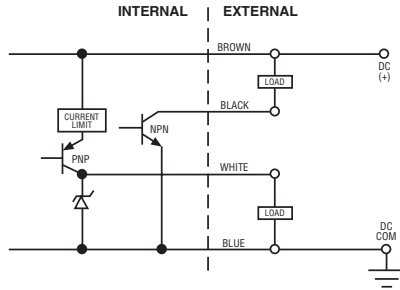

### AC Cable Models

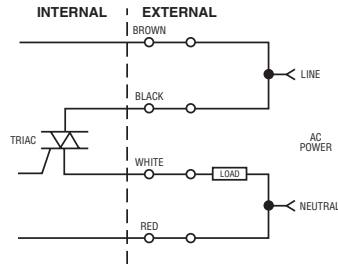

### AC Connector Models

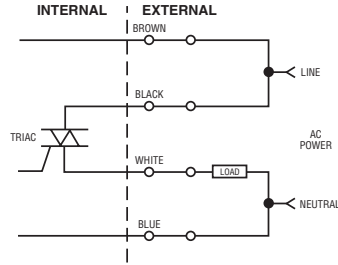

## Sensor Wire Connections

### DC Cable Models

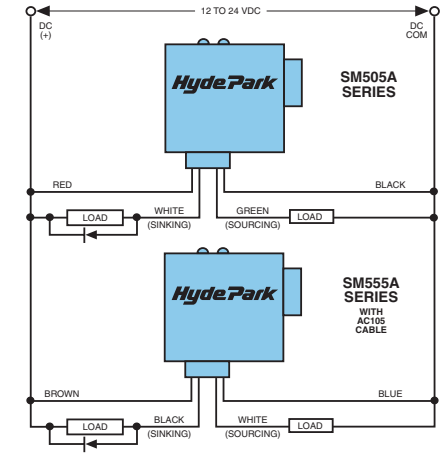

### AC Cable Models

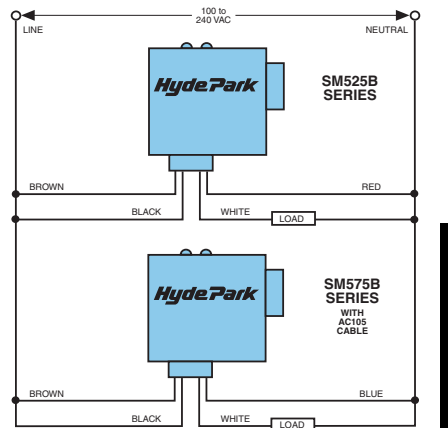

## Dimensions

### Cable Model

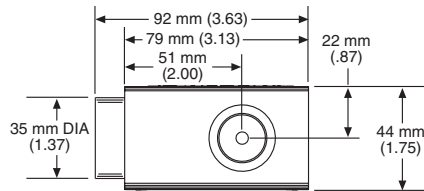
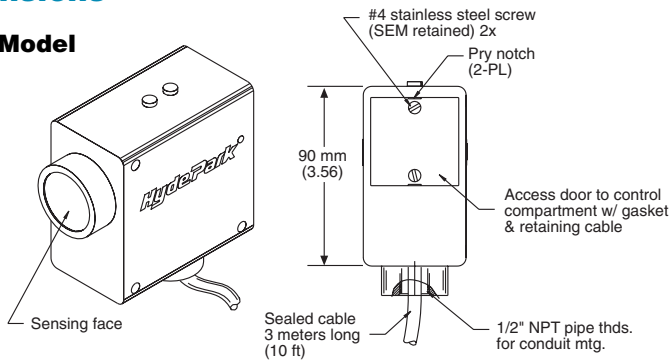

### Connector Model

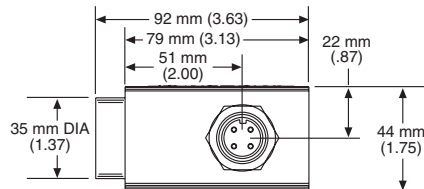
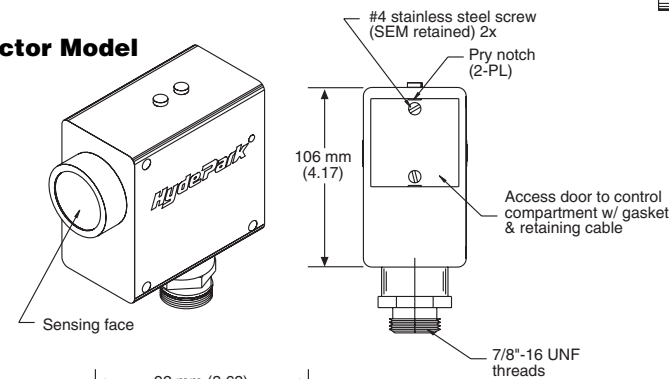

### Remote Sensing Models

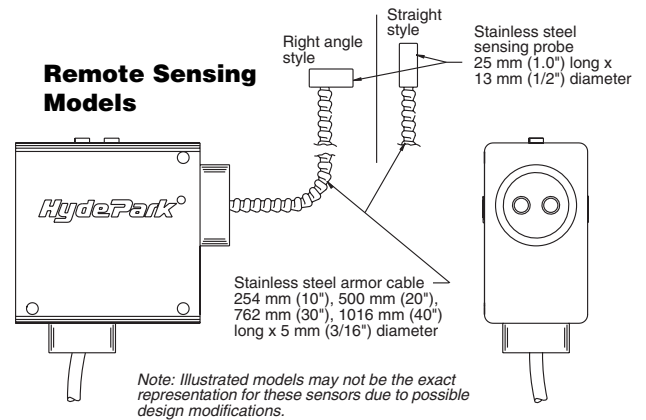

Note: Illustrated models may not be the exact representation for these sensors due to possible design modifications.

## Mounting Accessories

### AC230

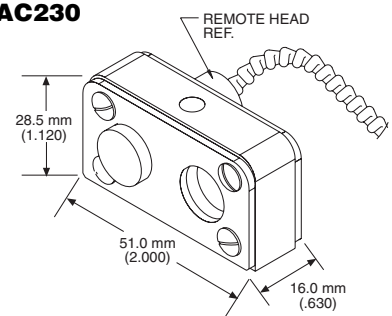

SUPERPROX® SM505 SERIES

## Mounting Accessories

### AC213

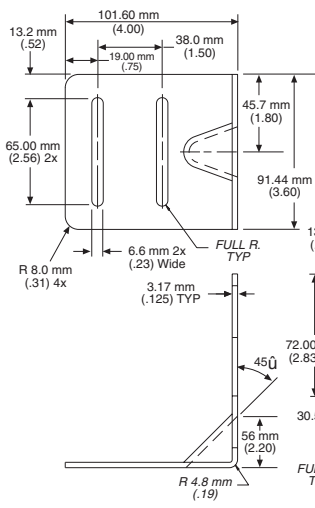
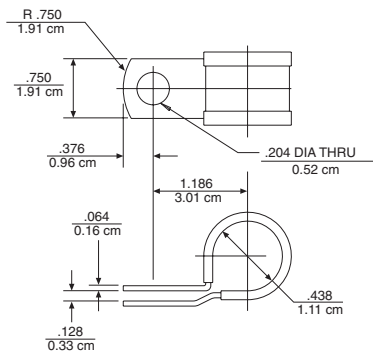

### AC229

### AC222

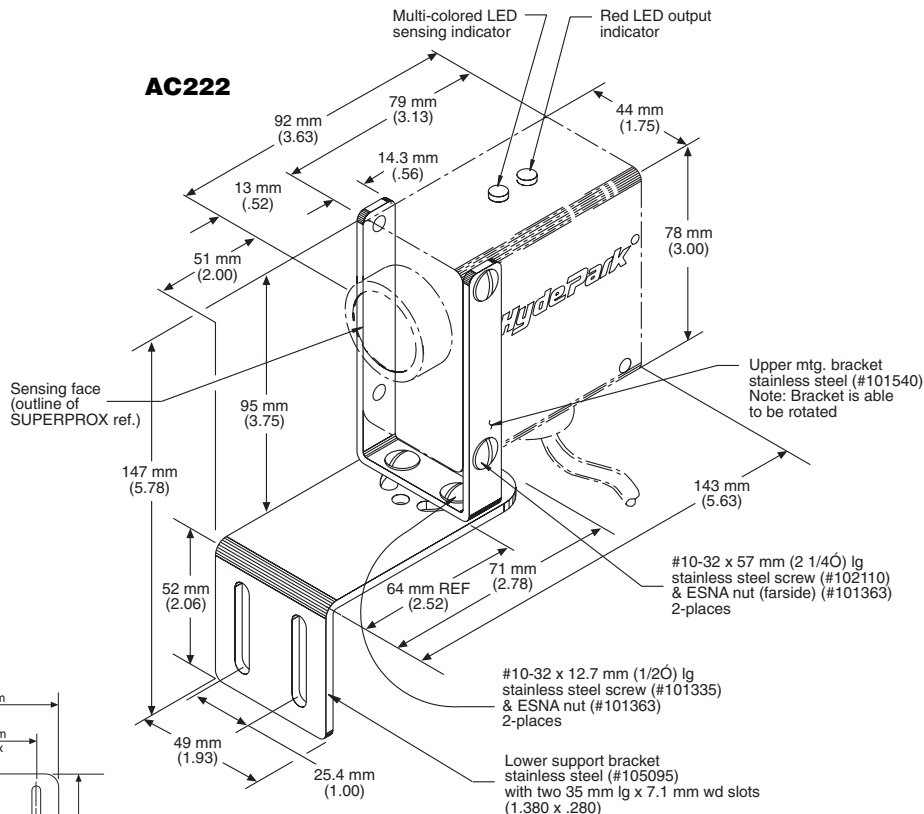

## General Specifications

### Sensing

Range:  
51 to 1 m (2 to 39')  
Sonic Frequency: 200 kHz

### Power Requirements

DC Models:  
12 to 24 VDC  $\pm$  10% @ 80 mA, 2 W max.,  
excluding output load (regulated supply)  
AC Models:  
100 to 240 VAC, 50/60 Hz, @ 30 mA, 7.5 VA max.,  
excluding load

### Outputs

DC Models:  
NPN Sinking: Switch selectable N.O./N.C.  
Sinking on-state voltage drop:  
Maximum 0.25 volts @ 60 mA  
Sinking load current:  
Maximum 100 mA  
Sinking output voltage:  
Maximum applied 30 VDC  
PNP Sourcing: Switch selectable N.O./N.C.  
Sourcing output current:  
Maximum 100 mA  
Current limit protected to less than 160 mA  
AC Models:  
Triac, switch selectable N.O./N.C.  
Maximum continuous load current: 1 Amp  
Maximum applied output voltage: 260 VAC  
Maximum off-state leakage current: less than  
50  $\mu$ A (100% PLC/AC input interface compatibility)

### Response Time

"On" 100 ms, "Off" 100 ms

### Indicators

Multicolored (Amber, Red, Green)  
LED: Indicates limits setup and  
operational modes

Red LED: Indicates sensor output; illuminated when  
output is in an active (on) state.

### Connections

Cable Style Models:  
DC: 24 AWG, PVC jacket, 4-conductor,  
3 meters (10') long, standard  
AC: 20 AWG, PVC jacket,  
4-conductor, 3 meters (10') long, standard  
Connector Style Models:  
DC: 4-pin, "mini" style  
AC: 4-pin "mini" style

### Protection

Power Supply: current-limited over-voltage, ESD,  
reverse polarity, fused on AC model  
Outputs: current-limited over voltage,  
ESD, over-current, fused TRIAC on AC model

### Environmental

Operating Temperature Range:  
0° to 50°C (32° to 122°F)  
Storage Temperature Range:  
-40° to 100°C (-40° to 212°F)  
Operating Humidity: 100%  
Protection Ratings: NEMA 4X, IP67  
Chemical Resistance: Resists most acids and  
bases, including most food products.  
Fluorosilicone transducer face is available to  
provide resistance to aromatic and petroleum-  
based hydrocarbons.

### Agency Approvals

CE Mark: CE conformity is declared to:  
EN61010-1: 1990 including amend. No.1:1992  
EN55011 Group 1 Class A, EN50082-1.

Declaration of conformity available upon request.

AC Models SM520/570 carry the ETL safety label.

### Construction

Dimensions (overall)  
92 mm (3.625") L x 44 mm (1.75") W x  
91 mm (3.58") H

### Housing:

Case: ULTEM®\* (FDA approved)  
Optional: NORYL®\* (USDA-Dairy 3A  
Sanitary Standards compliant)  
Transducer Face: Silicone rubber  
(FDA approved)  
Optional: Fluorosilicone rubber  
Sensor Cable: PVC jacket  
LED: Polycarbonate

\* ULTEM® and NORYL® are registered trademarks of The  
General Electric Co.

## Accessories

**Model AC105**, Straight, 7/8-16 mini, 4-conductor,  
mating connector cable, 4 m (12'), for connector-  
style sensors

**Model AC105-50**, Straight, 7/8-16 mini, 4-conductor,  
mating connector cable, 15 m (50'), for connector-  
style sensors

**Model AC213**, Stainless and Teflon, remote sensing  
probe mounting bracket

**Model AC222**, Standard, stainless mounting bracket  
assembly, slotted for vertical adjustment

**Model AC229**, Stainless, plate-style, right-angle,  
mounting bracket, with base slotted for forward/  
reverse adjustment and side slotted for sensor  
adjustment

**Model AC230**, Three-piece, stainless, mounting  
bracket assembly with O-ring mount for sensor  
models with remote heads.

See page 7-1 for accessory photos.

# Selection Chart

## SM505 Series Proximity Motion Sensing

Model No.	Power		Cable	Connector	Sensing Range	Standard	Transducer Style		Materials				Special Features
	100-240 VAC	Version					Remote	Rt. Angle	Transducer		Housing		
									Silicone*	Fluorosilicone*	ULTEM®*	NORYL®*	
SM505A-000	■	■	■	■	■	■			■	■			
SM505A-100		■	■	■	■	■			■	■			
SM525B-000	■		■	■	■	■			■	■			
SM525B-100	■		■	■	■	■			■	■			
SM555A-000		■	■	■	■	■			■	■			
SM555A-000 R4		■	■	■	■	■	■ (40°)		■	■			
SM555A-100		■	■	■	■	■			■	■			
SM575B-000	■		■	■	■	■			■	■			
SM575B-100	■		■	■	■	■			■	■			
SM575B-100 R4	■		■	■	■	■	■ (40°)		■	■			

• = Most commonly stocked sensors

\* = See definition in *Sensing Terms*.

All possible sensor configurations are not listed here.

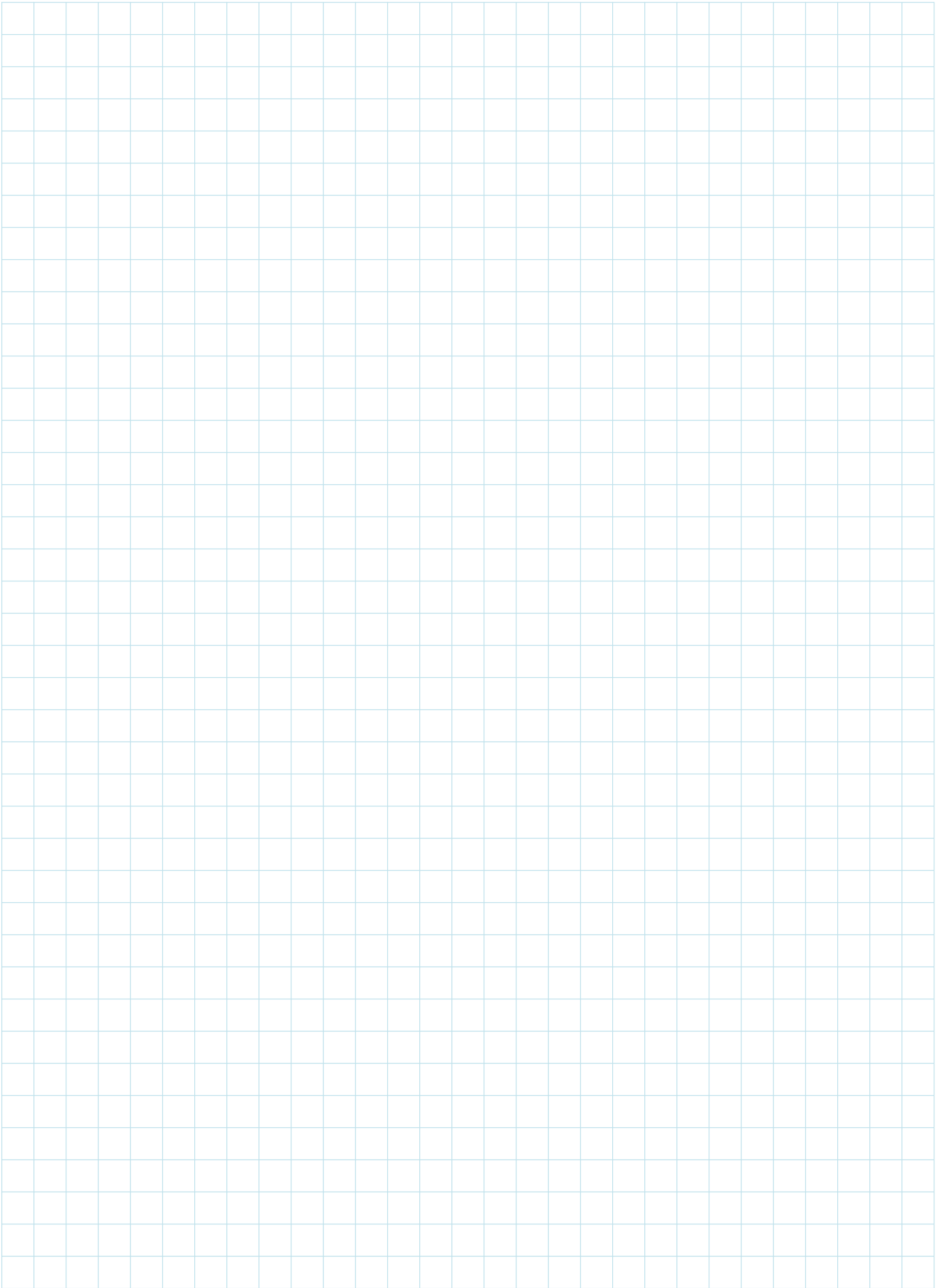

## Model SM506 Series

### SUPERPROX® Ultrasonic Analog Output Sensors



The SUPERPROX® Model SM506A (cable style) and Model SM556A (connector style) ultrasonic, noncontact sensors with a sensing range of 51 mm to 2 meters (2 to 79") are now available. These rugged sensors monitor the distance to an object while generating a proportional analog output relative to two

span limits which can be easily set with the push of a button. For applications such as maintaining a constant fill level in a filler machine, the analog output modulates the product flow into the filler as the filler speed changes. The analog output may modulate the speed of other machinery or regulate the movement of control valve actuators. Two discrete outputs, with setup and operation independent of the analog output span limits, provide alarm capability through the single sensor.

The analog output may also connect directly to programmable controller analog input modules for performing complex loop control or simple status (e.g., distance measuring) monitoring functions.

Easy to install and operate, these reliable SUPERPROX® DC-powered sensors carry the CE Mark. The sensor housing meets NEMA 4X, IP67 industry standards. A Dairy 3A compliant housing is available as an option.

- Easy push-button setup for setting sensing span limits
- Switch for selecting either direct or inverse proportional output
- 4 to 20 mA or 0 to 10 VDC selectable outputs
- Adjustable analog output response potentiometer
- SUPERPROX® housing meets IP67 and NEMA 4X industry standards
- CE certified

SUPERPROX® SM506  
SERIES

## Introduction

Hyde Park's SUPERPROX® sensors with analog output employ the latest in piezoelectric, ultrasonic, and microprocessor technology to provide reliable, noncontact, level, distance, or size measurement sensing for a wide variety of process-control applications.

As shown in Figures 1 and 3, these sensors have a sensing range of either 51 mm to 1 m (2 to 39") or 120 mm to 2 m (4.7 to 79"), at or within which the analog span limits and alarm set points (if selected) can be set.

## Models with Alarms

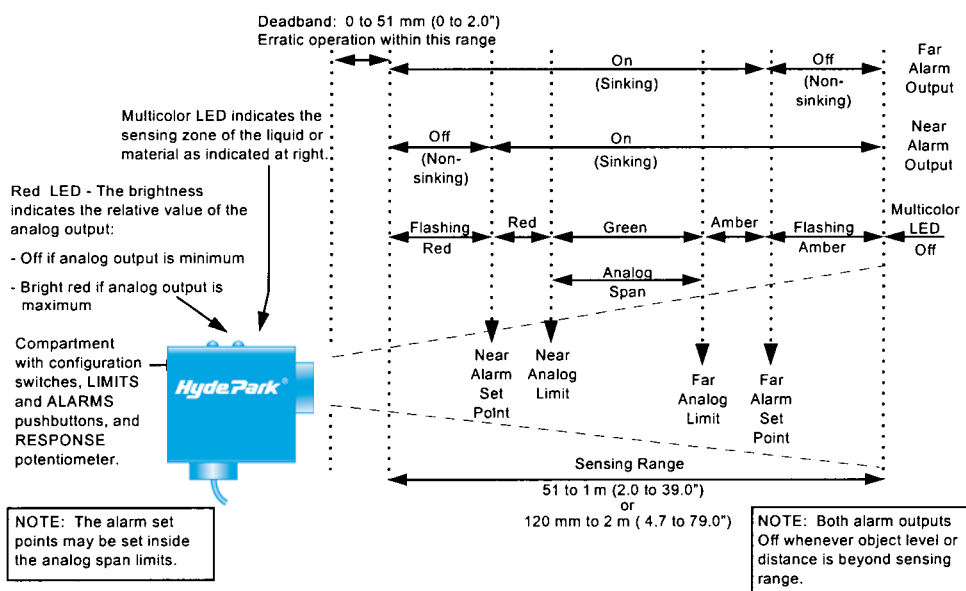

Figure 1

## Models without Alarms

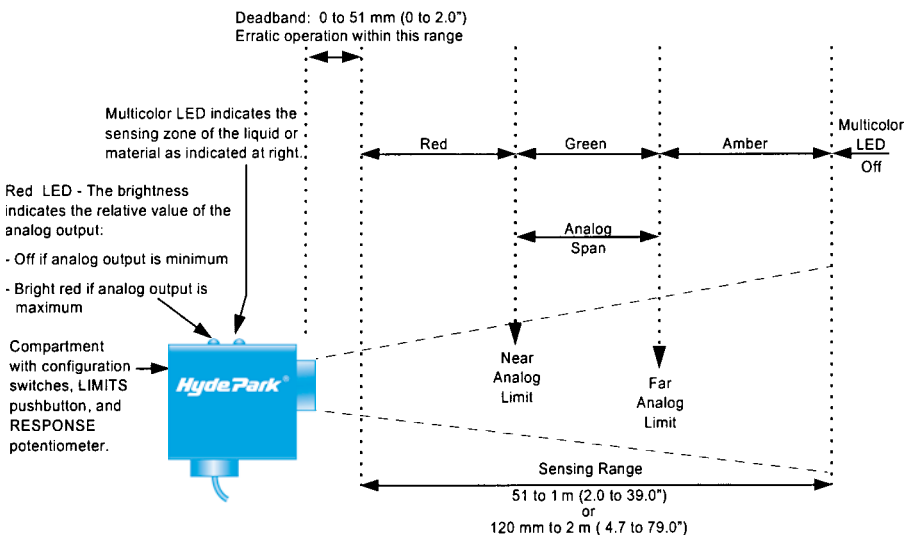

Figure 3

## Sensor is Quickly and Easily Configured

This is done through four dip switches, two push-buttons and a one-turn potentiometer located inside a watertight control compartment at the back side of the sensor (Fig. 2 and Fig.4). Access to the compartment is gained by loosening two flathead screws, inserting a small screwdriver in either the top or bottom slot and removing the square cover. A short plastic tether prevents separation of the cover from the sensor.

## Loss of Echo

Loss of echo occurs when the sensor does not receive echos from an object within its sensing range for more than one second. When this occurs, the analog signal will go to the minimum or maximum value depending on the position of configuration Switch 2. When the sensor again receives echos from within its sensing range, the analog signal is updated to a value indicating the object's present position relative to the span limits.

## "LE" Option - Function "00" & "81" or Hold Output on Loss of Echo - Function "98" & "99"

Depending on model functionality, when loss of echo occurs for more than one second, the analog signal will hold at the value of the last echo received. When the sensor again receives echos within its sensing range, the analog signal is updated to a value indicating the object's present position relative to the span limits.

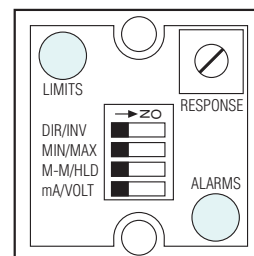

Figure 2 (with alarms)

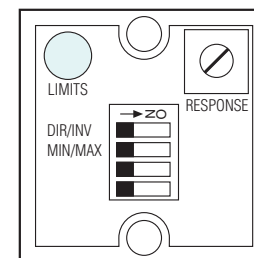

Figure 4 (without alarms)

## Sensor Configuration Switches

**Switch 1** (all models) selects either a directly (DIR) or inversely (INV) proportional (level or distance of an object relative to the span limits) analog output. When the switch is in the DIR position, the maximum analog output occurs at the limit closest to the sensor. When the switch is in the INV position, the maximum analog output occurs at the limit farthest from the sensor.

**Switch 2** selects the desired analog output on loss of echo for all models as shown in the chart below. For models with alarms, Switch 2 works with Switch

3 in selecting the state of the output. Switch 2 also determines the state of the output on power-up.

**Switch 3** (models with alarms only - not used on other models) selects whether the analog output goes to default, minimum or maximum output, or holds on loss of echo.

**Switch 4** (models with alarms only - not used on models dedicated to either 0-10 VDC or 4-20 mA output) selects either a current or voltage output. Place the switch in the VOLT position for 0-10 VDC or in the mA position for 4-20 mA.

Analog Models:	When		State of the Analog Output on Loss of Echo <sup>1</sup>
	Switch 2 set at:	Switch 3 set at:	
With alarms  (See note 2 for models with suffix 198.)	MIN	M-M	4 mA or 0 V (Alarms non-sinking and on)
	MAX	M-M	20 mA or 10 V (Alarms non-sinking and on)
	MIN	HLD	No change <sup>3</sup> (and no change in alarms)
	MAX	HLD	
Without alarms and no LE suffix  (See note 2 for models with suffix 118 & 188.)	MIN	Not used	4 mA or 0 V
	MAX		20 mA or 10 V
Without alarms and with LE suffix	MIN	Not used	No change <sup>3</sup>
	MAX		

- 1 Loss of echo occurs when sensor does not receive any echoes within its sensing range for more than one second.
  - 2 These sensor models ignore all echoes outside the programmed span.
  - 3 Means the output will hold at value of last echo received. When sensor again receives echoes within its sensing range, the outputs are updated to a value indicating the object's present position.
- NOTE: On power-up, the analog output

### Analog Response Time Potentiometer

As the position of a sensed object changes relative to the span limits, the analog output changes accordingly. In some applications, where there is rapid and erratic object movement or irregular object profiles and surfaces, it may be desirable to reduce the rate of output change. A one-turn RESPONSE potentiometer, located in the control compartment, allows adjustment or damping of

the analog output response to either abrupt or rapid changes in the object's position. The response is adjustable from 70 ms to 2.5 seconds, allowing smooth control regulation or speed modulation of process equipment. Figure 5 illustrates the relationship between the potentiometer setting and the output response time over the entire one-turn range.

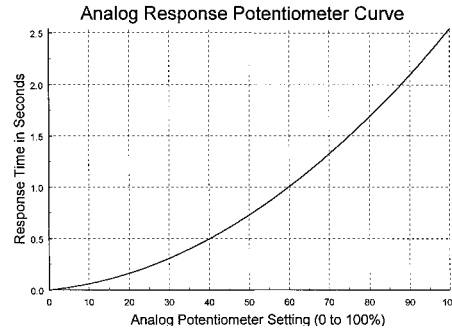

Figure 5

The output response is the time period required for the output signal to match 95% of a monitored abrupt change in object position. For example, assume Switch 1 is set to DIR and the potentiometer is set for a response time of 2.5 seconds (fully CW). At the far span limit the output is 4 mA. The object being detected has been stable at the far limit but then moves to the near span limit very rapidly. Two and one-half seconds after the object reaches the near limit, the analog output reaches 19.2 mA... or, (20 mA - 4 mA) .95 + 4 mA. Figure 6 illustrates the output response characteristics for 1.25 and 2.5 seconds.

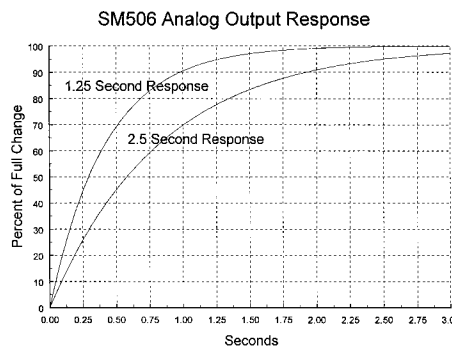

Figure 6

### The LIMITS & ALARMS Push-buttons

The LIMITS push-button is used to set both near and far limits of the analog span within which object detection and control takes place. After the limits have been set, the sensor continuously emits either a 0 to 10 VDC or 4 to 20 mA output that is in proportion to the object's position relative to the span limits. For example, if the output selected is 4-20 mA and the object is detected halfway

between the analog span limits, the output is 12 mA. The output range adjusts to the size of the analog span and remains proportional regardless of where the limits are set for the analog span.

Setting the limits begins by using a flat-surface target, approximately 150 mm x 150 mm (6" x 6") in size, and positioning it in front of and parallel to the face of the sensor. The operator moves the target the desired distance from the sensor that represents either the near or far selected span limit. One press of the LIMITS push-button lights the multicolored LED on top of the sensor amber and sets the limit at that distance. When the push-button is released, the LED flashes amber, indicating the other limit needs to be set. Moving a target to the second selected span limit position, which can be as close as 6.5 mm (1/4") from the other limit, and pressing the push-button again sets that limit. Again, while the push-button is depressed, the multicolored LED lights amber. Upon release of the push-button, the LED turns green to indicate acceptance of both span limits. At the same time, the sensor output switches from the inactive to active state, placing the sensor in operation, ready to use. If, in setting either span limit, the echo from the object is too weak or distorted, the multicolored LED flashes red for 10 seconds or until the push-button is pressed again. This indicates the limit setting was not accepted by the sensor. If power is interrupted or is turned off during operation, the span limits are retained in a nonvolatile memory.

During operation, as long as an object is within the analog span limits, the multicolored LED remains green. The other LED (always red) indicates the relative value of the analog output and varies in intensity according to the output. The higher the current or voltage output, the brighter the red LED. See Page 4-64 for further explanation.

The ALARMS push-button (on alarm models) is used to set two discrete alarm set points anywhere within the sensing range where alarm outputs are required to protect equipment from potential damage. An example would be the prevention of an overflow condition. Setting the alarm set points follows the same procedure as for the span limits with one exception: Upon release of the ALARMS push-button for the second alarm set point, the multicolored LED flashes amber for the farther (from the sensor) set point and flashes red for the nearer set point to indicate acceptance of both alarm set points.

## Multicolored LED status

### When setting analog span limits:

While LIMITS push-button is held in the first time at first limit:

- Amber - sensing solid, stable object
- Red - sensing unstable object or no object

After release of LIMITS push-button - first time, at first limit:

- Flashing Amber - first limit accepted, waiting for second limit
- Flashing Red - first limit invalid; retry

While LIMITS push-button is held in the first time at second limit:

- Amber - sensing solid, stable object
- Red - sensing unstable object or no object

After release of LIMITS push-button - first time, at second limit:

- Green or Red - second limit (near) accepted
- Green or Amber - second limit (far) accepted
- Flashing Red - second limit not accepted; begin again with first limit setup

### When setting alarm setpoints:

Press and release the ALARMS push-button with the object at the desired far-alarm set point.

- Flashing Amber - Far-alarm set point is set.

Press and release the ALARMS push-button with the object at the desired near-alarm set point.

- Flashing Red - Near-alarm set point is set.

NOTE: When either one of the alarm set points is reset at a different point, the other alarm set point must also be reset.

### During operation:

- Flashing Red - object sensed at or closer than the near-alarm set point.
- Red - object sensed between the near-alarm set point and the near limit.
- Green - object sensed at or between the near and far limits.
- Amber - object sensed between the far limit and the far-alarm set point.
- Flashing Amber - object sensed at or farther than the far-alarm set point.

- Off - no object sensed within the full sensing range.

### Red LED status during setup and operation:

During setup of sensor, the red LED has no significance. During operation, the brightness of the red LED indicates the relative value of the analog output. The red LED is off when the output is minimum and brightest red when the output is maximum.

## Electrical Wiring

These analog sensors are available as either three-wire or five-wire devices, depending on the configuration selected. The model with remote limits setup is either a four- or six-wire device, available only as a cable style model. NOTE: In order to avoid unwanted electrical interference, the sensor wires must be run in conduit separate from any AC power or control wires.

## Model Reference Guide - SM506 Series

Use the guide below to ensure the correct model number is specified for the application. Please note that not all sensor model combinations are available.

### EXAMPLE MODEL:

**SM506A-481-FSNS4**

#### SUPERPROX® Product Series

##### Power/Connection Type

- 0...15 to 24 VDC / cable style
- 5...15 to 24 VDC / connector style

##### Sensing Function

- 6...Proximity - analog

##### Design Level

- A...Applies to all models

##### Sensing Range

- 1...51 to 1 m (2 to 39")
- 4...120 mm to 2 m (4.7 to 79")

##### Functionality

- 00...4 to 20 mA
- 18...4 to 20 mA, ignore objects outside of span limits
- 81...0 to 10 VDC
- 88...0 to 10 VDC, ignore objects outside of span limits
- 98...Disable/enable loss of echo with high/low alarms, ignore objects outside of span limits
- 99...Disable/enable loss of echo with high/low alarms

##### Special Features

- ... No letter indicates standard sensor with no special features
- LE... No change in output on loss of echo
- FS... Fluorosilicone transducer face
- AA... Remote limit setup (Available on cable models only.)
- AB... RS232, 4-digit/2-decimal place output (Available on cable models only.)
- AD... Limits push-button disabled
- AE... RS232, 5-digit/3-decimal place output (Available on cable models only.)
- AF... No LEDs

##### Housing Types

- ...No letter indicates standard ULTEM® plastic housing
- N...NORYL® Dairy 3A gray plastic housing

##### Remote Type

- ... No letter indicates standard housing
- R...Right-angle sensing head with armor cable
- S...Straight sensing head with armor cable

##### Remote Cable Length

- ... No number indicates standard housing
  - 1...254 mm (10")
  - 2...508 mm (20")
  - 3...762 mm (30")
  - 4...1016 mm (40")
  - 5P...1270 mm (50")
  - 6P...1524 mm (60")
- } Armored (standard) or PVC cable (specify P after number)
- Available in PVC cable only

\*ULTEM® and NORYL® are registered trademarks of The General Electric Company.



**3-Wire Sensor Wire Colors**

Power (+)	Cable Style	Connector Style
15 to 24 VDC	RED	BROWN (4-Pin)
Analog Output (4 to 20 mA or 0 to 10 VDC)	WHITE	BLACK
Power Common	BLACK	BLUE
Signal Common		WHITE
Remote Push-button (Option)	BLUE	Not Available

**3-Wire Connections**

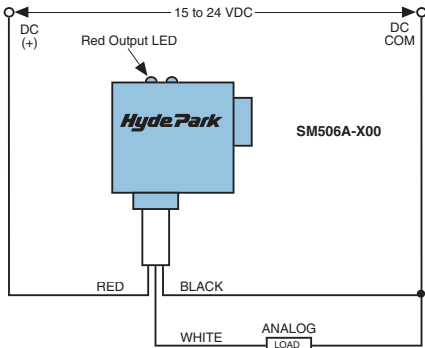

**4-Wire Connections**

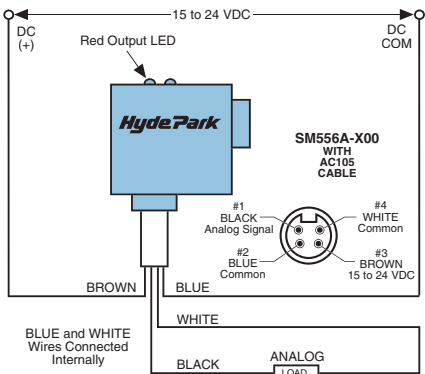

**5-Wire Sensor Wire Colors**

Power (+)	Cable Style	Connector Style
15 to 24 VDC	RED	BROWN (5-Pin)
Analog Output (4 to 20 mA or 0 to 10 VDC)	WHITE	BLACK
Common	BLACK	BLUE
Near-Alarm Limit	GREEN	WHITE
Far-Alarm Limit	BROWN	ORANGE
Remote Push-button (Option)	BLUE	Not Available

**5-Wire Connections**

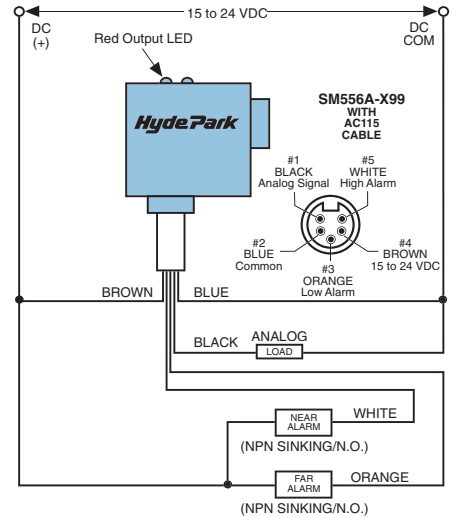
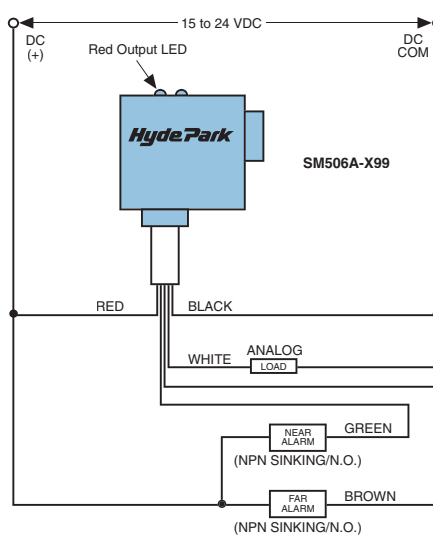

**\*WARNING:**

The analog output "COMMON" is internally connected to earth ground. An isolated signal transmitter is required when using the controller with ungrounded analog input process control devices.

**Remote Sensing Models**

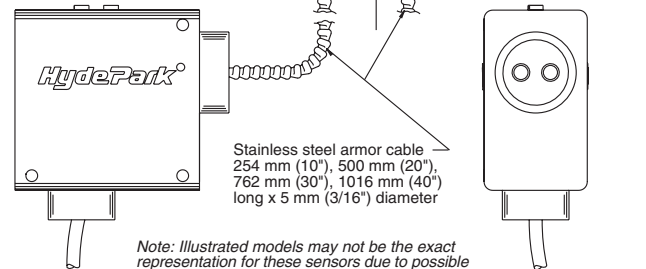

Note: Illustrated models may not be the exact representation for these sensors due to possible design modifications.

**Dimensions**

**Cable Model**

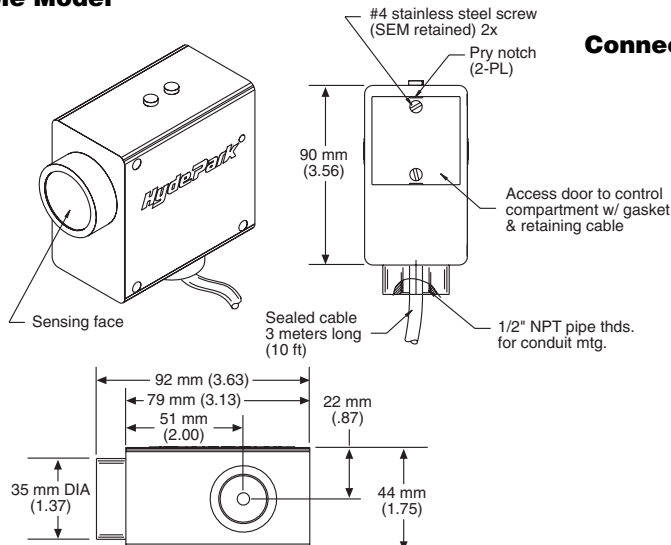

**Connector Model**

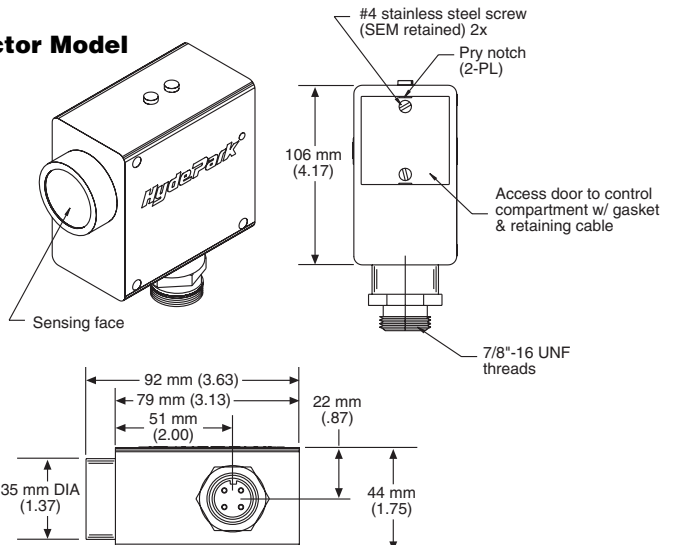

## Mounting Accessories

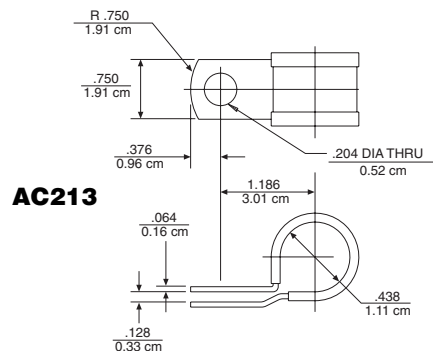
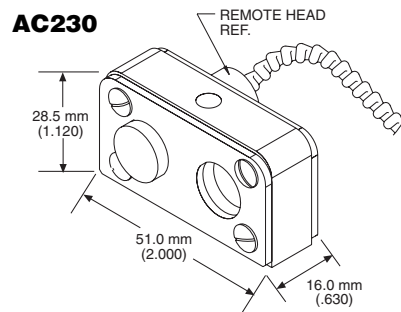
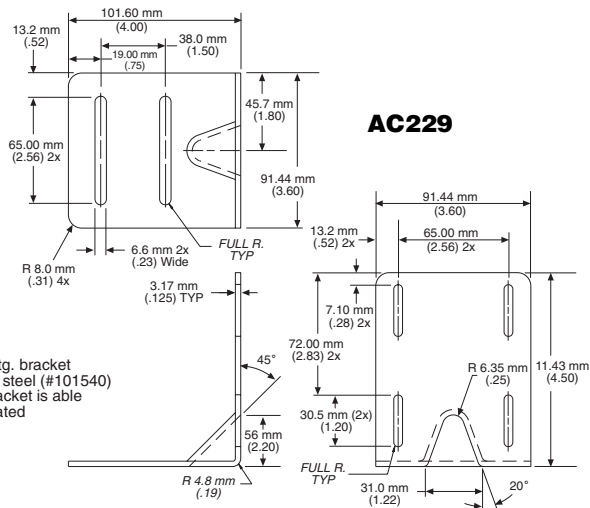
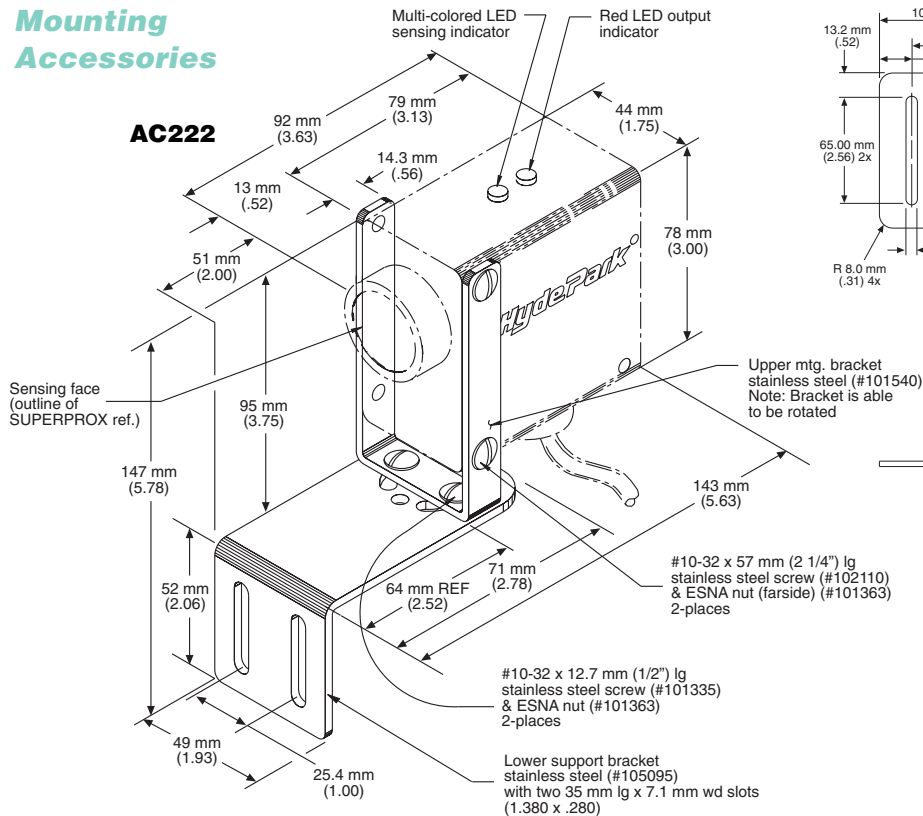

## General Specifications

### Sensing

#### Ranges:

- 51 to 1000 mm (2" to 39")
- 120 mm to 2 m (4.7" to 79") - DC model only

#### Sonic Frequency: 200 kHz

#### Maximum Plane-reflector Angle:

- ± 10° on 305 mm x 305 mm (12" x 12") flat target at a distance of 305 mm (12")

#### Sonic Cone Angle: 26° @ 762 mm (30")

### Analog Output Electrical Specifications

(Test conditions: 24 VDC, T<sub>A</sub> = 20°C, large flat target, still air)

	current output <sup>1</sup>	voltage output <sup>2</sup>	units
Output Range	4-20 mA	0-10 V	
Load Resistance	10 to 1K	200 to ∞	Ohms
Resolution <sup>3</sup>	0.004 mA	2.5 mVDC	
Accuracy <sup>4</sup>	± 0.50	± 0.40	% of span
Linearity	± 0.10	± 0.10	% of span
Temperature dependence	± 0.006	± 0.004	% of span/°C

<sup>1</sup> tested with 250 Ohm load

<sup>2</sup> tested with 470 Ohm load; a low value is recommended to minimize noise pickup

<sup>3</sup> resolution = span/4000; maximum: 0.08 mm (0.003")

<sup>4</sup> best accuracy may be limited to + 1/32 +0.794 mm (0.03125") due to wave-skip phenomena

### Power Requirements

#### DC Models:

- 15 to 24 VDC ± 10% @ 80 mA excluding output load

### Outputs

- Switch selectable for either 4 to 20 mA or 0 to 10 VDC in alarm models only. Other models dedicated to either 4 to 20 mA or 0 to 10 VDC. Non-isolated

### Sinking Outputs:

- Maximum on-state voltage drop @ 60mA: 0.25 volts
- Maximum load current: 100 mA
- Maximum applied voltage: 35 VDC

### Response Time

- 0.07 to 2.5 seconds
- (See analog output response curves.)

### Indicators

- Multicolored (Amber, Red, Green) LED: Indicates Limits-setup and operational modes
- Red LED: Visual indicator for analog output; intensity varies as output magnitude changes.

### Connections

#### Cable Style Models:

- DC: 24 AWG, PVC jacket, 3-,4-, or 5-conductor, 3 meters (10') long, standard

#### Connector Style Models:

- DC: 24 AWG, 4- or 5-pin "mini" style

### Protection

- Power Supply: Current-limited over-voltage, ESD, reverse polarity
- Outputs: Current-limited over-voltage, ESD, over-current

### Environmental

#### Operating Temperature Range:

- 0° to 50°C (32° to 122°F)

#### Storage Temperature Range:

- 40° to 100°C (-40° to 212°F)

#### Operating Humidity: 100%

#### Protection Ratings:

- NEMA 4X, IP67

#### Chemical Resistance:

- Resists most acids and bases, including most food products. Fluorosilicone transducer face is available to provide resistance to aromatic and petroleum-based hydrocarbons.

### Agency Approvals

#### CE Mark: CE conformity is declared to:

- EN61010-1: 1990 including amend. No.1:1992
- EN55011 Group 1 Class A, EN50082-1.

Declaration of conformity available upon request.

AC Models SM520/570 carry the ETL safety label.

### Construction

#### Dimensions (overall)

- 92 mm (3.625") L x 44 mm (1.75") W x 91 mm (3.50") H cable style

#### Housing:

- Shock and vibration resistant
- Case: ULTEM®\* (FDA approved)
- Optional: NORLYL®\* (USDA-Dairy 3A Sanitary Standards compliant)
- Transducer Face: Silicone rubber (FDA approved)
- Optional: Fluorosilicone rubber
- Sensor Cable: PVC jacket
- LED: Polycarbonate

\* ULTEM® and NORLYL® are registered trademarks of The General Electric Co.

---

## Accessories

**Model AC105**, Straight, 7/8-16 mini, 4-conductor, mating connector cable, 4 m (12'), for connector-style sensors

**Model AC105-50**, Straight, 7/8-16 mini, 4-conductor, mating connector cable, 15 m (50'), for connector-style sensors

**Model AC115**, Straight, 7/8-16 mini, 5-conductor, mating connector cable, 4 m (12'), for Model SM556A-X9X series analog, connector-style prox sensors with alarms

**Model AC115-50**, Straight, 7/8-16 mini, 5-conductor, mating connector cable, 15 m (50'), for Model SM556A-X9X series analog, connector-style prox sensors with alarms

**Model AC213**, Stainless and Teflon, remote sensing probe mounting bracket

**Model AC222**, Standard, stainless mounting bracket assembly, slotted for vertical adjustment

**Model AC229**, Stainless, plate-style, right-angle, mounting bracket, with base slotted for forward/reverse adjustment and side slotted for sensor adjustment

**Model AC230**, Three-piece, stainless, mounting bracket assembly with O-ring mount for sensor models with remote heads.

See page 7-1 for accessory photos.

# Selection Chart

## SM506 Series Analog Output

Model No.	Power Version		Connection Style	Sensing Range			Transducer Style		Analog Output		Transducer Materials				Loss of Echo <sup>1)</sup>	High/Low Alarms	Ignore object outside of span limits	Notes	Special Features
	15/24 VDC	Cable		Connector	2m (79")	1 m (39")	Standard	Rt. Angle	Remote	0-10 VDC	4-20 mA	Selectable	Silicone*	Fluorosilicone*					
SM506A-100•	■	■		■	■				■	■		■	■	■					
SM506A-100 AB	■	■		■	■				■	■		■	■	■				RS232 output	
SM506A-100 FS	■	■		■	■				■	■		■	■	■					
SM506A-100 LE•	■	■		■	■				■	■		■	■	■	■				
SM506A-100 LER4	■	■		■	■			■ (40°)	■	■		■	■	■	■				
SM506A-100 N	■	■		■	■				■	■		■	■	■	■				
SM506A-100 R2	■	■		■	■			■ (20°)	■	■		■	■	■	■				
SM506A-100 S4	■	■		■	■			■ (40°)	■	■		■	■	■	■				
SM506A-118	■	■		■	■				■	■		■	■	■	■	■			
SM506A-181	■	■		■	■				■	■		■	■	■	■				
SM506A-181 AA	■	■		■	■				■	■		■	■	■	■			Remote limit setup	
SM506A-181 LE	■	■		■	■				■	■		■	■	■	■				
SM506A-181 LER2	■	■		■	■				■	■		■	■	■	■				
SM506A-181 S1	■	■		■	■			■ (10°)	■	■		■	■	■	■				
SM506A-181 S4	■	■		■	■			■ (40°)	■	■		■	■	■	■				
SM506A-188	■	■		■	■				■	■		■	■	■	■	■			
SM506A-188 AA	■	■		■	■				■	■		■	■	■	■	■		Remote limit setup	
SM506A-198•	■	■		■	■				■	■		■	■	■	■	■	■	Disable/enable loss of echo	
SM506A-198 AA	■	■		■	■				■	■		■	■	■	■	■	■	Disable/enable loss of echo, Remote limit setup	
SM506A-198 R2	■	■		■	■			■ (20°)	■	■		■	■	■	■	■	■	Disable/enable loss of echo	
SM506A-198 R3	■	■		■	■			■ (30°)	■	■		■	■	■	■	■	■	Disable/enable loss of echo	
SM506A-199•	■	■		■	■				■	■		■	■	■	■	■	■	Disable/enable loss of echo	
SM506A-199 AA	■	■		■	■				■	■		■	■	■	■	■	■	Disable/enable loss of echo, Remote limit setup	
SM506A-199 FS	■	■		■	■				■	■		■	■	■	■	■	■	Disable/enable loss of echo	
SM506A-199 R2	■	■		■	■			■ (20°)	■	■		■	■	■	■	■	■	Disable/enable loss of echo	
SM506A-199 R3	■	■		■	■			■ (30°)	■	■		■	■	■	■	■	■	Disable/enable loss of echo	
SM506A-400	■	■		■	■				■	■		■	■	■	■	■	■		
SM506A-400 LE	■	■		■	■				■	■		■	■	■	■	■	■		
SM506A-418	■	■		■	■				■	■		■	■	■	■	■	■		
SM506A-481	■	■		■	■				■	■		■	■	■	■	■	■		
SM506A-481 LE	■	■		■	■				■	■		■	■	■	■	■	■		
SM506A-488	■	■		■	■				■	■		■	■	■	■	■	■		
SM506A-498•	■	■		■	■				■	■		■	■	■	■	■	■	Disable/enable loss of echo	
SM506A-498 AA	■	■		■	■				■	■		■	■	■	■	■	■	Disable/enable loss of echo, Remote limit setup	
SM506A-499•	■	■		■	■				■	■		■	■	■	■	■	■	Disable/enable loss of echo	
SM556A-100•	■	■		■	■				■	■		■	■	■	■	■	■		
SM556A-100 FS	■	■		■	■				■	■		■	■	■	■	■	■		
SM556A-100 LE•	■	■		■	■				■	■		■	■	■	■	■	■		
SM556A-100 LEN	■	■		■	■				■	■		■	■	■	■	■	■		
SM556A-100 LER4	■	■		■	■			■ (40°)	■	■		■	■	■	■	■	■		
SM556A-100 R4	■	■		■	■			■ (40°)	■	■		■	■	■	■	■	■		
SM556A-100 S4	■	■		■	■			■ (40°)	■	■		■	■	■	■	■	■		
SM556A-118	■	■		■	■				■	■		■	■	■	■	■	■		
SM556A-181	■	■		■	■				■	■		■	■	■	■	■	■		
SM556A-181 FS	■	■		■	■				■	■		■	■	■	■	■	■		
SM556A-181 LE	■	■		■	■				■	■		■	■	■	■	■	■		
SM556A-181 R2	■	■		■	■			■ (20°)	■	■		■	■	■	■	■	■		
SM556A-188	■	■		■	■				■	■		■	■	■	■	■	■		
SM556A-188 AD	■	■		■	■				■	■		■	■	■	■	■	■	Limits push-button disabled	
SM556A-198•	■	■		■	■				■	■		■	■	■	■	■	■	Disable/enable loss of echo	
SM556A-199•	■	■		■	■				■	■		■	■	■	■	■	■	Disable/enable loss of echo	
SM556A-199 FS	■	■		■	■				■	■		■	■	■	■	■	■	Disable/enable loss of echo	
SM556A-199 N	■	■		■	■				■	■		■	■	■	■	■	■	Disable/enable loss of echo	
SM556A-199 R2	■	■		■	■			■ (20°)	■	■		■	■	■	■	■	■	Disable/enable loss of echo	
SM556A-199 R4	■	■		■	■			■ (40°)	■	■		■	■	■	■	■	■	Disable/enable loss of echo	
SM556A-400•	■	■		■	■				■	■		■	■	■	■	■	■		
SM556A-400 LE	■	■		■	■				■	■		■	■	■	■	■	■		
SM556A-400 N	■	■		■	■				■	■		■	■	■	■	■	■		

# Selection Chart

## SM506 Series (cont.) Analog Output

Model No.	Power Version		Connection		Sensing Range		Transducer Style		Analog Output		Transducer Materials		Housing		Loss of Echo		Notes	Special Features	
	15/24 VDC	Cable	Connector	Style	2m (79')	1m (39')	Standard	Rt. Angle	Remote	Straight	0-10 VDC	4-20 mA	Selectable	Silicone*	Fluorosilicone*	ULTEM®*			NORYL®*
SM556A-418	■	■	■	■	■	■	■				■			■			■		
SM556A-481	■	■	■	■	■	■	■				■			■			■		
SM556A-481 LE	■	■	■	■	■	■	■				■			■			■		
SM556A-488	■	■	■	■	■	■	■				■			■			■		
SM556A-498•	■	■	■	■	■	■	■					■	■	■			■	■	Disable/enable loss of echo
SM556A-499•	■	■	■	■	■	■	■					■	■	■			■	■	Disable/enable loss of echo
SM556A-499 N	■	■	■	■	■	■	■					■	■	■			■		Disable/enable loss of echo

□ No change in output on loss of echo

• = Most commonly stocked sensors

\* = See definition in *Sensing Terms*.

All possible sensor configurations are not listed here.

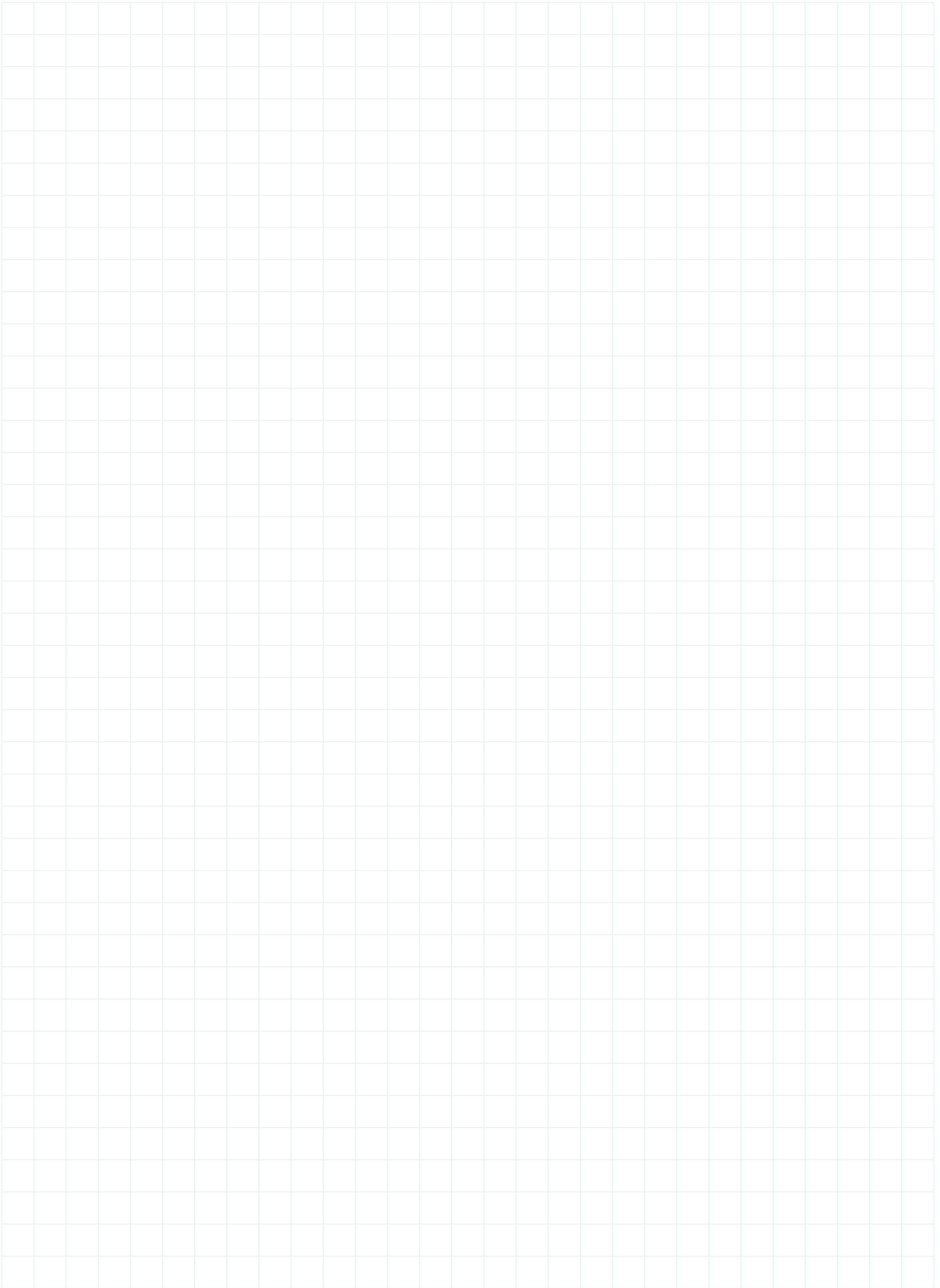

# SUPERPROX® 600 Series Introduction



*DeviceNet.*

## **Now available... one of the world's finest series of ultrasonic proximity sensors**

Built on a long tradition of excellence in ultrasonic, proximity sensing achieved by the SUPERPROX® 500 sensor series, an array of ultrasonics now offers an added dimension in object detection and control. The SUPERPROX® 600 series of sensors, by virtue of their size, powerful sensing performance and versatility, extends the limits of opportunities for accurate, reliable sensing for industries everywhere. Including those applications previously assigned to other less reliable, less productive sensing devices.

Available in 18 mm barrel models, housed in rugged ULTEM® plastic or stainless steel, and a new compact "flat-profile" housing of ULTEM® plastic, these sensors fit easily in areas where sensor space is

very limited. Protection Ratings of NEMA 4X and IP67 help to ensure nonstop operation, day in and day out. Like the SUPERPROX® 500 series, these sensors resist wet, harsh environments, dust, ambient light, high noise levels, frequent high-pressure washdown, and severe duty applications. Once set up and operating, these miniatures need very little attention. Even under the messiest conditions, they reliably detect most every kind of material...especially clear glass, plastic, and film...an important advantage over many photoelectric sensors. Changing light conditions and colors have no effect on sensing capability and no sensitivity adjustments are necessary to compensate for inconsistent materials.

Unlike the SM500 series, the SM600 series has fixed, as opposed to push-button set, sensing "windows" within which the object detection takes place.

## *18 mm & Flat-Profile Ultrasonic Sensors*

**SUPERPROX® Model SM600 Series**  
*Proximity Sensing*

**SUPERPROX® Model SM602**  
*Dual-Level Sensing*

**SUPERPROX® Model SM606**  
*Distance Sensing with Analog Output*

**SUPERPROX® Model SM607**  
*Small-Target Sensing*

- *Field programmable capability in 18 mm and flat-profile models*
- *DeviceNet capability in flat-profile models*
- *CE certified*

A variety of different fixed sensing windows are available within each specific model series. These and other features make the sensors the perfect fit for achieving optimum productivity in many sensing applications.

For sensing applications requiring connection to a DeviceNet network, the flat-profile models in this series are available with this capability as an optional selection.

## **Field Configurable Sensor Models**

SUPERPROX+® software combined with the Model AC441A configurator interface

**SUPERPROX® SM600  
SERIES INTRO**

module enables the SUPERPROX 600 series sensors to be programmed by the user with either standard or custom sensing configurations. These field configurable sensors use an 'SC' prefix in the model number to designate and differentiate the sensors from factory configured SUPERPROX 600 series models.

All the unique sensing capabilities and functions available in the SUPERPROX SM600, 602, 606, and 607 sensor series are also available in field configurable SC600/606 models. An even greater sensing capability in functionality is realized with these field configurable sensor models through the user-friendly SUPERPROX+™ software to allow customization for specific applications.

For more details on the Model SC600 series and other field configurable sensor models along with the Model AC441A configurator interface module go to the SUPERPROX+™ section found on page 4-145 in the catalog.

### Operation

The SUPERPROX® 600 series is a self-contained, pulse-echo device that both transmits and receives sonic energy within its programmed sensing range. Like the SUPERPROX® 500 series, these sensors use the latest ultrasonic technology along with a discriminating microprocessor to ignore all surrounding sonic interference and detect only the designated object. An object is detected when it is at or within the fixed sensing window.

### How does it work?

During setup and operation, the SM600 series sensors continually and accurately measure the elapsed time of every pulse echo reception between each pulse transmission. The transmitted pulse begins a time clock to register the elapsed times for the received pulse echoes. Given the elapsed time, the sensor software calculates the distance traveled out to the object and back to the sensor, using the formula,  $D = Tv_s/2$ , where: D = distance from the sensor to the object; T = elapsed time between the pulse transmission and its echo receptions,  $V_s$  = the velocity of sound, approximately 1100 feet per second.

During operation, the calculated distance (D) between the sensor and the object is compared to the distances between the sensor and the fixed window limits. These limits are shown in the illustration below as  $D_{wi}$  and  $D_{wo}$ . If D is at or within the fixed window limits, an output change takes place and remains unchanged until the echo either does not return or it returns from outside the fixed window limits. In the case of

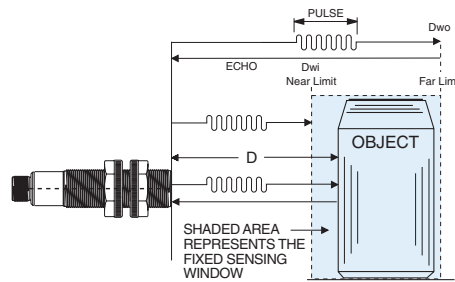

the Model SM606 series, an analog output changes proportionally with respect to the limits of the analog sensing span.

### The SUPERPROX® 600 Series meets a variety of important sensing needs.

The SUPERPROX® 600 series sensors represent simple but reliable object detection with a variety of sensing windows and sensing ranges up to 254 mm (10"). The sensor outputs are either discrete sinking and sourcing or 0 to 10 V analog.

### Applications

For applications specific to the four series of SUPERPROX® 600 series sensors, see either the product information sections that follow or the Application/Sensor Selection Chart on Page 2-1.

### For increased productivity in challenging proximity sensing applications...

consider this new line of SUPERPROX® ultrasonic, proximity sensors. Whether the application calls for the barrel or flat-profile type, accuracy, and reliability are the primary benefits realized. And that translates to increased productivity and profitability.

### Beam Plots

The following plot, developed from data collected at 20°C, zero air flow, define the boundaries and shape of the sonic beam for various Hyde Park ultrasonic sensor series.

The boundaries were established using a 10 cm x 10 cm (3.94" x 3.94") "target" positioned parallel to the sensor face. The plot for each sensor series is valid for targets equal to or larger than 10 cm x 10 cm. Beam boundaries are determined by moving the large flat target into the beam while the plane of the target is held perpendicular to the beam axis.

In each series, the plot extends from the end of the "deadband" on the left to the end of the sensing range on the right. The sensor is illustrated in the middle left margin.

This and other plots are available from Hyde Park upon request.

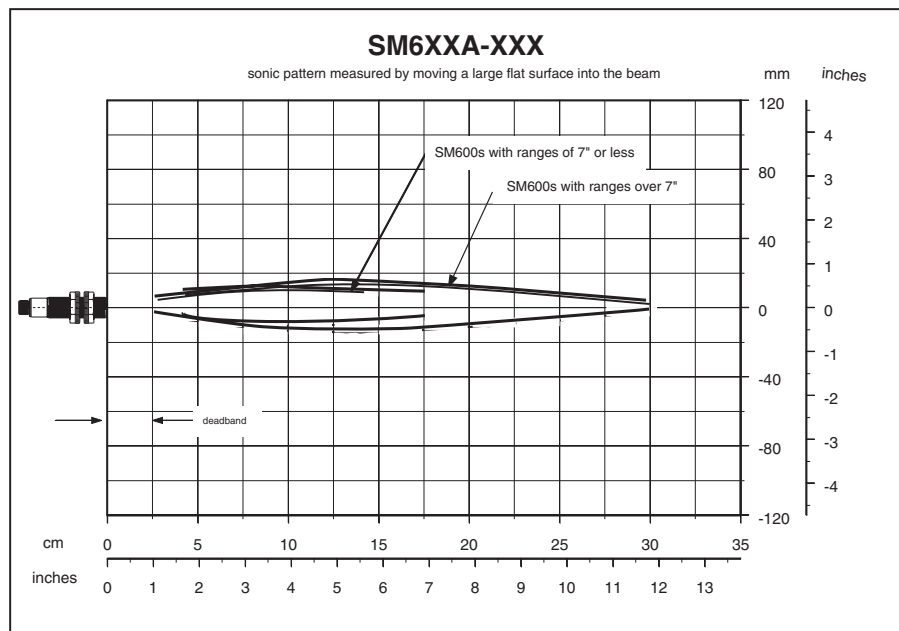



## SUPERPROX<sup>®</sup> Ultrasonic Proximity Sensors

### Long-range Proximity Sensing



### Now there's a reliable ultrasonic solution for those tough proximity sensing applications.

When short-range sensing applications demand repeatable and reliable on/off control performance, the high-frequency, fixed-window SUPERPROX<sup>®</sup> Model SM600 series ultrasonic proximity sensors are the ideal solution. These noncontact, self-contained sensors are unmatched for the reliable detection of objects of all kinds, transparent or opaque, liquid or solid, and as small as 1.6 mm (0.06") rod diameter, regardless of color or shape. Offering a variety of sensing ranges, up to 305 mm (12"), and fixed sensing windows, this series provides for the convenient placement of SM600 sensors throughout the plant.

Given the capability to "back off" from formerly "nearly-touching" mounting positions, these sensors are the solution for such applications as: metal parts as close as 25 mm (1"), moving back-to-back at speeds in

excess of 2000 per minute. Others include: cap presence and/or tilt detection, fill-level checking, fill-tube-presence monitoring, downed container detection, case inspection, detection of container edges, web monitoring, and CD case inspection where opacity, color, and height vary, and wherever there's a need to upgrade a metal prox function.

With protection ratings of NEMA 4X and IP67, these sensors are impervious to changing light conditions, colors, noise, dust, 100% humidity, caustic chemicals, and other hostile environments. They are resistant to most acids and bases, including most food products. The sensing transducer is made of silicone rubber and the sensors are CE certified. Easy to install, the sensors are available in two different housing styles: the 18mm barrel housing sensor available in either ULTEM<sup>®</sup> plastic (standard) or SS303 stainless steel and the flat-profile housing available only in ULTEM<sup>®</sup> plastic. As with all SUPERPROX<sup>®</sup> sensors, cable and connector styles are available.

- High resolution 500 kHz ultrasonic frequency
- Fast response - as fast as 1.5 ms sampling rate
- Self-contained, 18 mm barrel or flat-profile housing styles
- Field programmable capability in 18 mm and flat-profile models
- DeviceNet capability available in flat-profile models
- CE certified

For sensing applications requiring connection to a DeviceNet network, the flat-profile models in this series are available with this capability as an optional selection.

Operating on 12 to 24 VDC, the 500 kHz sensors are equipped with sinking type (NPN) and sourcing type (PNP) outputs, a green LED to indicate power "on" and an amber LED to indicate when the object is detected within the fixed window.

Built from the world's finest and most reliable ultrasonic technology, the SUPERPROX<sup>®</sup> Model SM600 barrel- and flat-profile-style proximity sensors are the answer for improved productivity throughout the plant.

## Operation

The SUPERPROX® Model SM600 series is a self-contained, pulse-echo device that both transmits and receives sonic energy over a sensing range of up to 254 mm (10"). These sensors use the latest ultrasonic technology with a discriminating microprocessor that allows the sensor to ignore all surrounding sonic interference and detect only the designated object. An object is detected when it is at or within the fixed sensing window.

## How does it work?

During setup and operation, these SM600 series sensors continually and accurately measure the elapsed time of every pulse echo reception between each pulse transmission. The transmitted pulse begins a time clock to register the elapsed times for the

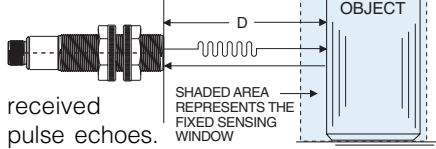

received pulse echoes. Given the elapsed time, the sensor software calculates the distance traveled out to the object and back to the sensor, using the formula,  $D = TV_s/2$ , where:  $D$  = distance from the sensor to the object;  $T$  = elapsed time between the pulse transmission and its echo receptions,  $V_s$  = the velocity of sound, approximately 1100 feet per second.

During operation, the calculated distance ( $D$ ) between the sensor and the object is compared to the distances between the sensor and the fixed window limits. These limits are shown in the illustration as  $D_{wi}$  and  $D_{wo}$ . If  $D$  is at or within the fixed window limits, an output

## Model Reference Guide - SM600 Series

Use the guide below to ensure the correct model number is specified for the application. Please note that not all sensor model combinations are available.

### EXAMPLE MODEL:

**SM6 0 0 A - 2 16 - 00 S**

### Ultrasonic Miniature Proximity Series

#### Power/Connection Type

- 0...12 to 24 VDC / cable style
- 5...12 to 24 VDC / "micro" connector style
- 6...12 to 24 VDC / "micro" connector style (output pins reversed)

#### Sensing Function

- 0...Proximity Style - no on/off delay

#### Design Level

- A...Applies to all models

#### Sensing Range (Far Limit)

- |                 |                  |
|-----------------|------------------|
| 2...51 mm (2")  | 6...152 mm (6")  |
| 3...77 mm (3")  | 7...178 mm (7")  |
| 4...102 mm (4") | B...254 mm (10") |
| 5...127 mm (5") |                  |

#### Sensing Window (Distance from Far Limit to Near Limit)\*\*

- |                    |                  |
|--------------------|------------------|
| 02...3.2 mm (1/8") | 32...51 mm (2")  |
| 04...6.4 mm (1/4") | 48...77 mm (3")  |
| 08...13 mm (1/2")  | 80...127 mm (5") |
| 12...19 mm (3/4")  | 96...152 mm (6") |
| 16...25 mm (1")    | OB...203 mm (8") |

#### Functionality

- 00...Standard on/off, N.O. output
- 10...N.C. output

[Contact the factory for additional functionality options]

#### Housing Types

- ...No letter indicates standard ULTEM® plastic -18 mm barrel housing
- FP...ULTEM® flat-profile housing
- S...SS303 stainless steel - 18 mm barrel housing

ULTEM® is a registered trademark of The General Electric Company.

\*\*Not allowed inside the deadband. Deadband is 0.75" for ranges -7", and 1.25" for ranges > 7"

Field configurable and DeviceNet Model Reference Guides start on page 4-145.

change takes place and remains unchanged until the echo either does not return or it returns from outside the fixed window limits.

As shown below, Hyde Park offers

normally open (N.O.) or normally closed (N.C.) (sinking and sourcing) output models available for discrete on/off sensing applications.

## Normally Open Output

The sensor output is "On" with the object in the fixed sensing window.

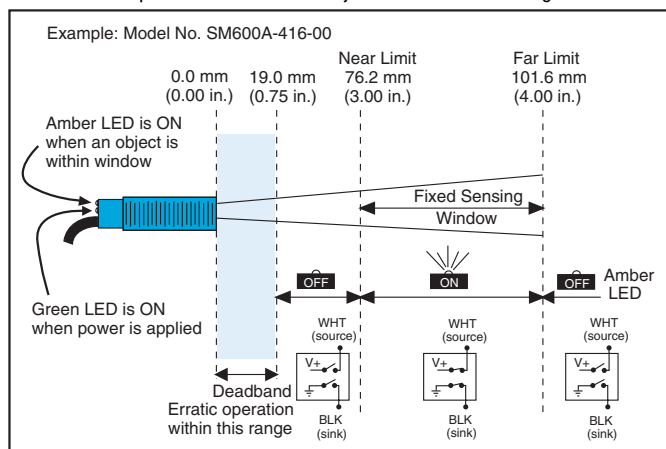

## Normally Closed Output

The sensor output is "Off" with the object in the fixed sensing window.

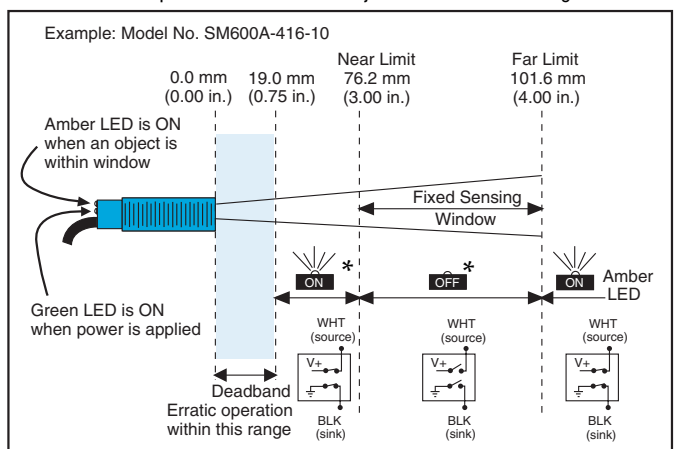

\* For connector style, LED states are reversed

## Mounting

The Model SM600 series sensors should be mounted in brackets that allow them to be adjusted for proper alignment. Hyde Park offers the Model AC226 stainless and polyamide conveyor-rail clamp/bracket set, Model AC227 large, right-angle, stainless mounting bracket, Model AC228 small, right-angle, stainless, mounting bracket, Model AC231 straight, stainless, mounting bracket and Model AC232 s-shaped, stainless, mounting bracket which are illustrated, with dimensions, on Pages 4-76 and 4-77.

## Electrical Wiring

Regardless of model style, the wiring and conductor colors for the Model SM600 series sensors are the same.

### Cable Style Model Wire Assignments

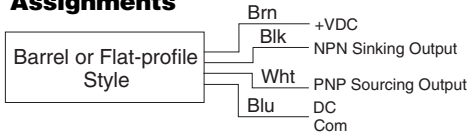

## Outputs

### NPN Sinking and PNP Sourcing

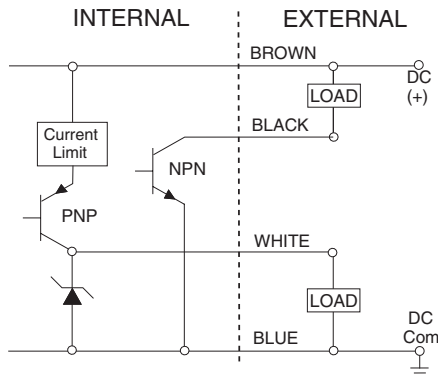

### Connector Style Model Pin Assignments

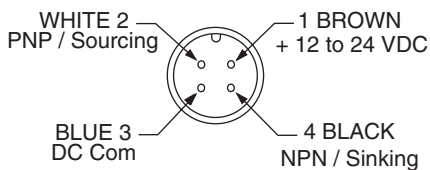

## Dimensions

### Barrel Cable Style

(ULTEM® plastic and stainless steel)

SM600A-XXX-XX,  
SM600A-XXX-XXS

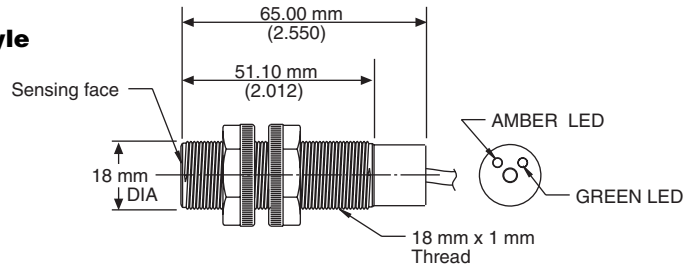

### Barrel Connector Style

(ULTEM® plastic and stainless steel)

SM650A-XXX-XX,  
SM650A-XXX-XXS

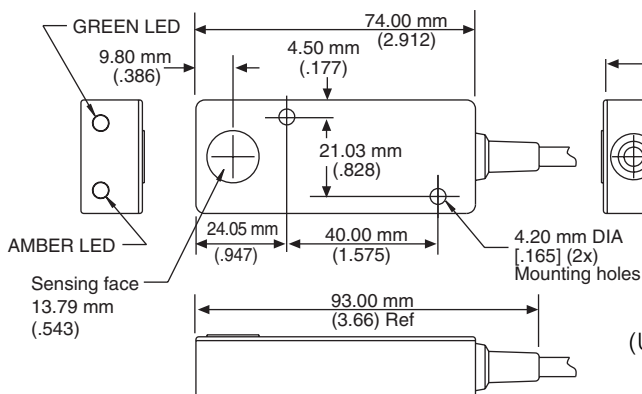
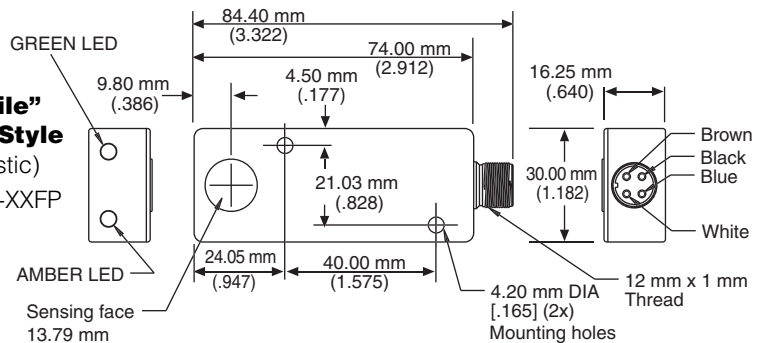
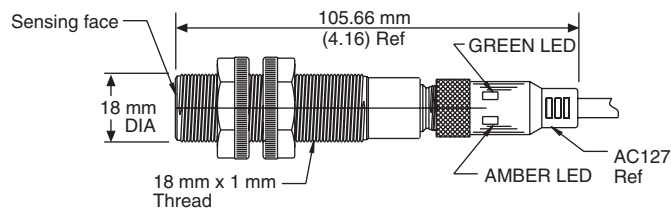
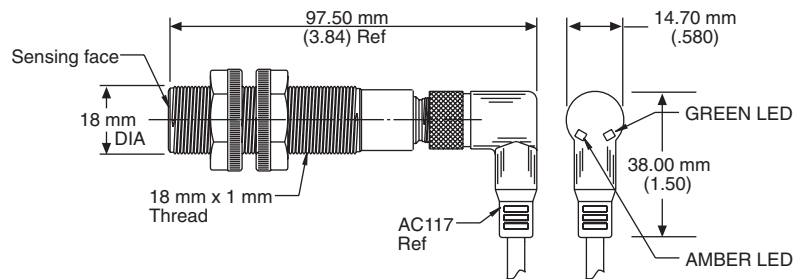
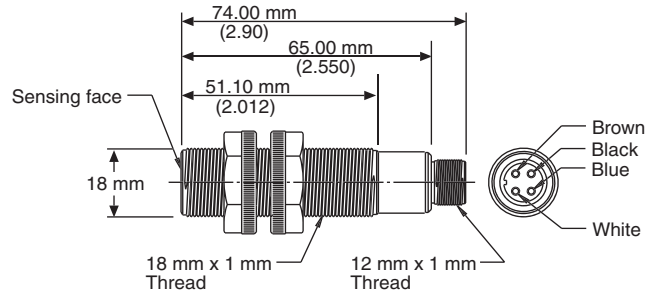

### "Flat-profile" Cable Style

(ULTEM® plastic)  
SM600A-XXX-XXFP

## Mounting Accessories

**AC117** Right-angle, M12 micro, 4-conductor, connector/cable assembly, 5 m (16'), with built-in LEDs (for barrel connector-style sensors)

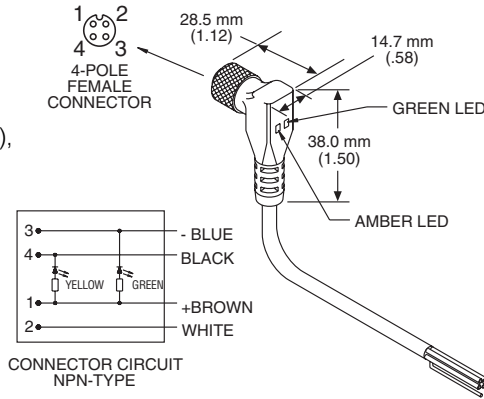

**AC127** Straight, M12 micro, 4-conductor, connector/cable assembly, 5 m (16'), with built-in LEDs (for barrel connector-style sensors)

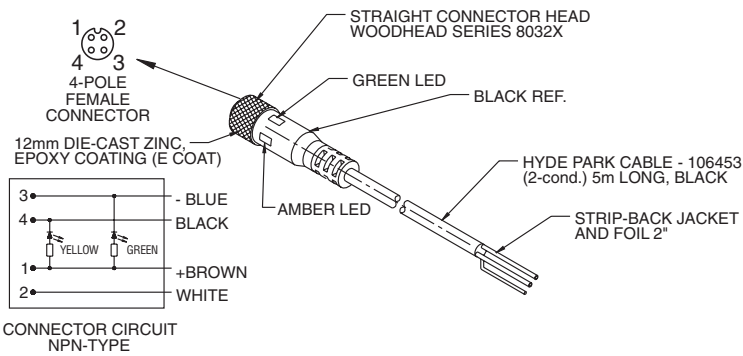

**AC130** Straight, M12 micro, 4-conductor, connector/cable assembly, 5 m (16') (for flat-profile connector-style sensors)

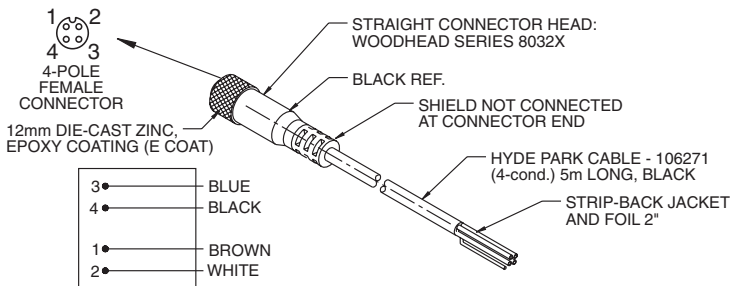

**AC226** Stainless and polyamide conveyor-rail clamp/bracket set (for 18 mm barrel sensors)

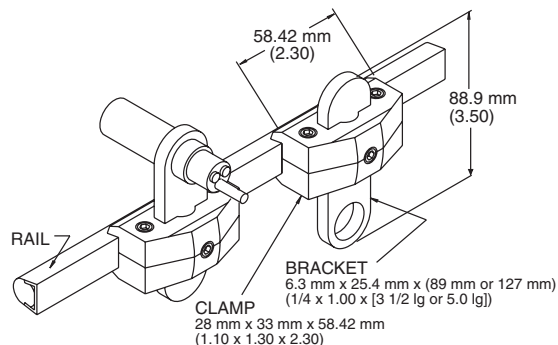

**AC227** Large, right-angle, stainless, mounting bracket (for 18 mm barrel sensors)

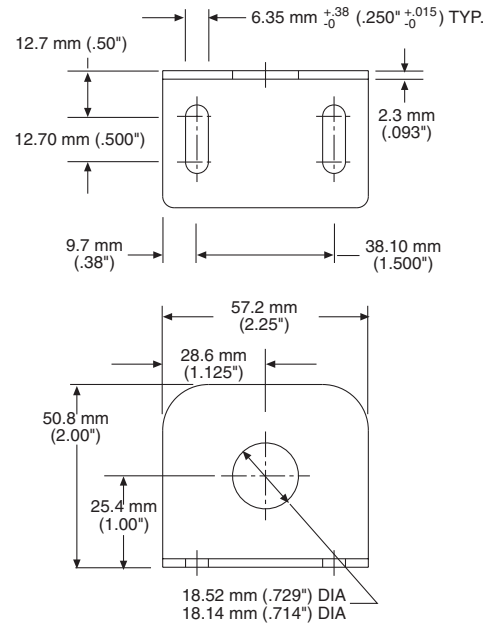

**AC228** Small, right-angle, stainless, mounting bracket (for 18 mm barrel sensors)

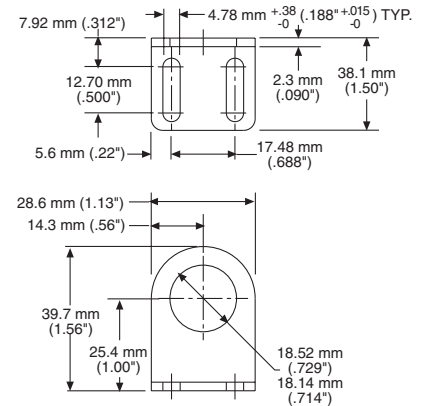

**AC132**, Right-angle, M12 micro, 4-conductor, connector/cable assembly, 5 m (16'), for flat-profile connector-style sensors

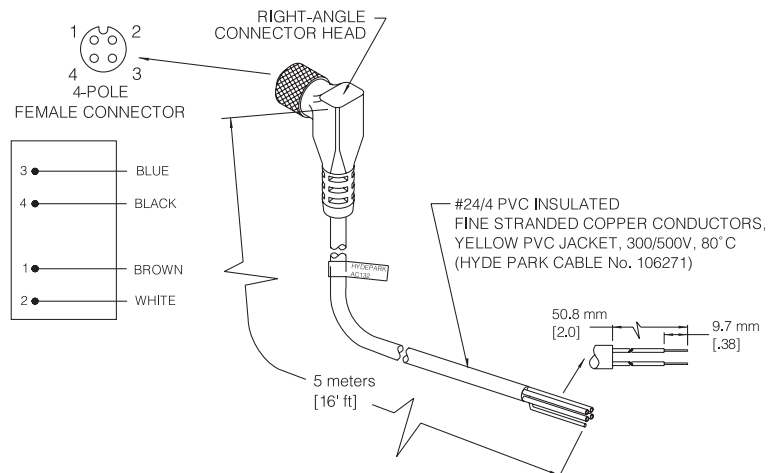



# Selection Chart

## SM600 Series

### Proximity

Model No.	Power		Connection Style		Range	Window	Transducer	Materials			Special Features	
	12-24 VDC	Cable	Connector	Connector Output Pins Rev				Silicone*	18mm ULTEM®	18mm Stainless	Flat-profile ULTEM®	Standard On/Off
SM600A-201-00	■	■			51mm (2")	1.6mm (1/16")	■	■				
SM600A-201-00FP	■	■			51mm (2")	1.6mm (1/16")	■			■	■	
SM600A-201-00S	■	■			51mm (2")	1.6mm (1/16")	■		■			
SM600A-201-10	■	■			51mm (2")	1.6mm (1/16")	■	■				■
SM600A-201-10FP	■	■			51mm (2")	1.6mm (1/16")	■			■		■
SM600A-201-10S	■	■			51mm (2")	1.6mm (1/16")	■		■			■
SM600A-208-00	■	■			51mm (2")	13mm (1/2")	■	■			■	
SM600A-208-00FP	■	■			51mm (2")	13mm (1/2")	■			■	■	
SM600A-208-00S	■	■			51mm (2")	13mm (1/2")	■		■		■	
SM600A-208-10	■	■			51mm (2")	13mm (1/2")	■	■				■
SM600A-208-10FP	■	■			51mm (2")	13mm (1/2")	■			■		■
SM600A-208-10S	■	■			51mm (2")	13mm (1/2")	■		■			■
SM600A-212-00	■	■			51mm (2")	19mm (3/4")	■	■			■	
SM600A-212-00FP	■	■			51mm (2")	19mm (3/4")	■			■	■	
SM600A-212-00S	■	■			51mm (2")	19mm (3/4")	■		■		■	
SM600A-212-10	■	■			51mm (2")	19mm (3/4")	■	■				■
SM600A-212-10FP	■	■			51mm (2")	19mm (3/4")	■			■		■
SM600A-212-10S	■	■			51mm (2")	19mm (3/4")	■		■			■
SM600A-216-00•	■	■			51mm (2")	25mm (1")	■	■			■	
SM600A-216-00FP•	■	■			51mm (2")	25mm (1")	■			■	■	
SM600A-216-00S•	■	■			51mm (2")	25mm (1")	■		■		■	
SM600A-216-10	■	■			51mm (2")	25mm (1")	■	■				■
SM600A-216-10FP	■	■			51mm (2")	25mm (1")	■			■		■
SM600A-216-10S	■	■			51mm (2")	25mm (1")	■		■			■
SM600A-301-00	■	■			77mm (3")	1.6mm (1/16")	■	■			■	
SM600A-301-00FP	■	■			77mm (3")	1.6mm (1/16")	■			■	■	
SM600A-301-00S	■	■			77mm (3")	1.6mm (1/16")	■		■		■	
SM600A-301-10	■	■			77mm (3")	1.6mm (1/16")	■	■				■
SM600A-301-10FP	■	■			77mm (3")	1.6mm (1/16")	■			■		■
SM600A-301-10S	■	■			77mm (3")	1.6mm (1/16")	■		■			■
SM600A-308-00	■	■			77mm (3")	13mm (1/2")	■	■			■	
SM600A-308-00FP	■	■			77mm (3")	13mm (1/2")	■			■	■	
SM600A-308-00S	■	■			77mm (3")	13mm (1/2")	■		■		■	
SM600A-308-10	■	■			77mm (3")	13mm (1/2")	■	■				■
SM600A-308-10FP	■	■			77mm (3")	13mm (1/2")	■			■		■
SM600A-308-10S	■	■			77mm (3")	13mm (1/2")	■		■			■
SM600A-312-00	■	■			77mm (3")	19mm (3/4")	■	■			■	
SM600A-312-00FP	■	■			77mm (3")	19mm (3/4")	■			■	■	
SM600A-312-00S	■	■			77mm (3")	19mm (3/4")	■		■		■	
SM600A-312-10	■	■			77mm (3")	19mm (3/4")	■	■				■
SM600A-312-10FP	■	■			77mm (3")	19mm (3/4")	■			■		■
SM600A-312-10S	■	■			77mm (3")	19mm (3/4")	■		■			■
SM600A-316-00	■	■			77mm (3")	25mm (1")	■	■			■	
SM600A-316-00FP	■	■			77mm (3")	25mm (1")	■			■	■	
SM600A-316-00S	■	■			77mm (3")	25mm (1")	■		■		■	
SM600A-316-10	■	■			77mm (3")	25mm (1")	■	■				■
SM600A-316-10FP	■	■			77mm (3")	25mm (1")	■			■		■
SM600A-316-10S	■	■			77mm (3")	25mm (1")	■		■			■
SM600A-332-00	■	■			77mm (3")	51mm (2")	■	■			■	
SM600A-332-00FP	■	■			77mm (3")	51mm (2")	■			■	■	
SM600A-332-00S	■	■			77mm (3")	51mm (2")	■		■		■	
SM600A-332-10	■	■			77mm (3")	51mm (2")	■	■				■
SM600A-332-10FP	■	■			77mm (3")	51mm (2")	■			■		■
SM600A-332-10S	■	■			77mm (3")	51mm (2")	■		■			■
SM600A-401-00	■	■			102mm (4")	1.6mm (1/16")	■	■			■	
SM600A-401-00FP	■	■			102mm (4")	1.6mm (1/16")	■			■	■	
SM600A-401-00S	■	■			102mm (4")	1.6mm (1/16")	■		■		■	
SM600A-401-10	■	■			102mm (4")	1.6mm (1/16")	■	■				■
SM600A-401-10FP	■	■			102mm (4")	1.6mm (1/16")	■			■		■
SM600A-401-10S	■	■			102mm (4")	1.6mm (1/16")	■		■			■
SM600A-408-00	■	■			102mm (4")	13mm (1/2")	■	■			■	
SM600A-408-00FP	■	■			102mm (4")	13mm (1/2")	■			■	■	
SM600A-408-00S	■	■			102mm (4")	13mm (1/2")	■		■		■	

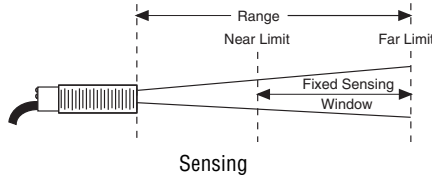

# Selection Chart

## SM600 Series (cont.) Proximity

Model No.	Power		Connection Style		Range	Sensing Window	Transducer	Materials			Special Features	
	12-24 VDC	Cable	Connector	Connector Output Pins Rev				Silicone*	18mm ULTEM®	18mm Stainless	Fiat-profile ULTEM®	Standard On/Off N.O. Output
SM600A-408-10	■	■			102mm (4")	13mm (1/2")	■	■				■
SM600A-408-10FP	■	■			102mm (4")	13mm (1/2")	■			■		■
SM600A-408-10S	■	■			102mm (4")	13mm (1/2")	■		■			■
SM600A-412-00	■	■			102mm (4")	19mm (3/4")	■	■				
SM600A-412-00FP	■	■			102mm (4")	19mm (3/4")	■			■		
SM600A-412-00S	■	■			102mm (4")	19mm (3/4")	■		■			
SM600A-412-10	■	■			102mm (4")	19mm (3/4")	■	■				■
SM600A-412-10FP	■	■			102mm (4")	19mm (3/4")	■			■		■
SM600A-412-10S	■	■			102mm (4")	19mm (3/4")	■		■			■
SM600A-416-00	■	■			102mm (4")	25mm (1")	■	■				
SM600A-416-00FP	■	■			102mm (4")	25mm (1")	■			■		
SM600A-416-00S	■	■			102mm (4")	25mm (1")	■		■			
SM600A-416-10	■	■			102mm (4")	25mm (1")	■	■				■
SM600A-416-10FP	■	■			102mm (4")	25mm (1")	■			■		■
SM600A-416-10S	■	■			102mm (4")	25mm (1")	■		■			■
SM600A-432-00	■	■			102mm (4")	51mm (2")	■	■				
SM600A-432-00FP	■	■			102mm (4")	51mm (2")	■			■		
SM600A-432-00S	■	■			102mm (4")	51mm (2")	■		■			
SM600A-432-10	■	■			102mm (4")	51mm (2")	■	■				■
SM600A-432-10FP	■	■			102mm (4")	51mm (2")	■			■		■
SM600A-432-10S	■	■			102mm (4")	51mm (2")	■		■			■
SM600A-448-00*	■	■			102mm (4")	77mm (3")	■	■				
SM600A-448-00FP*	■	■			102mm (4")	77mm (3")	■			■		
SM600A-448-00S*	■	■			102mm (4")	77mm (3")	■		■			
SM600A-448-10	■	■			102mm (4")	77mm (3")	■	■				■
SM600A-448-10FP	■	■			102mm (4")	77mm (3")	■			■		■
SM600A-448-10S	■	■			102mm (4")	77mm (3")	■		■			■
SM600A-501-00	■	■			127mm (5")	1.6mm (1/16")	■	■				
SM600A-501-00FP	■	■			127mm (5")	1.6mm (1/16")	■			■		
SM600A-501-00S	■	■			127mm (5")	1.6mm (1/16")	■		■			
SM600A-501-10	■	■			127mm (5")	1.6mm (1/16")	■	■				■
SM600A-501-10FP	■	■			127mm (5")	1.6mm (1/16")	■			■		■
SM600A-501-10S	■	■			127mm (5")	1.6mm (1/16")	■		■			■
SM600A-508-00	■	■			127mm (5")	13mm (1/2")	■	■				
SM600A-508-00FP	■	■			127mm (5")	13mm (1/2")	■			■		
SM600A-508-00S	■	■			127mm (5")	13mm (1/2")	■		■			
SM600A-508-10	■	■			127mm (5")	13mm (1/2")	■	■				■
SM600A-508-10FP	■	■			127mm (5")	13mm (1/2")	■			■		■
SM600A-508-10S	■	■			127mm (5")	13mm (1/2")	■		■			■
SM600A-512-00	■	■			127mm (5")	19mm (3/4")	■	■				
SM600A-512-00FP	■	■			127mm (5")	19mm (3/4")	■			■		
SM600A-512-00S	■	■			127mm (5")	19mm (3/4")	■		■			
SM600A-512-10	■	■			127mm (5")	19mm (3/4")	■	■				■
SM600A-512-10FP	■	■			127mm (5")	19mm (3/4")	■			■		■
SM600A-512-10S	■	■			127mm (5")	19mm (3/4")	■		■			■
SM600A-516-00	■	■			127mm (5")	25mm (1")	■	■				
SM600A-516-00FP	■	■			127mm (5")	25mm (1")	■			■		
SM600A-516-00S	■	■			127mm (5")	25mm (1")	■		■			
SM600A-516-10	■	■			127mm (5")	25mm (1")	■	■				■
SM600A-516-10FP	■	■			127mm (5")	25mm (1")	■			■		■
SM600A-516-10S	■	■			127mm (5")	25mm (1")	■		■			■
SM600A-532-00	■	■			127mm (5")	51mm (2")	■	■				
SM600A-532-00FP	■	■			127mm (5")	51mm (2")	■			■		
SM600A-532-00S	■	■			127mm (5")	51mm (2")	■		■			
SM600A-532-10	■	■			127mm (5")	51mm (2")	■	■				■
SM600A-532-10FP	■	■			127mm (5")	51mm (2")	■			■		■
SM600A-532-10S	■	■			127mm (5")	51mm (2")	■		■			■
SM600A-548-00	■	■			127mm (5")	77mm (3")	■	■				
SM600A-548-00FP	■	■			127mm (5")	77mm (3")	■			■		
SM600A-548-00S	■	■			127mm (5")	77mm (3")	■		■			
SM600A-548-10	■	■			127mm (5")	77mm (3")	■	■				■
SM600A-548-10FP	■	■			127mm (5")	77mm (3")	■			■		■
SM600A-548-10S	■	■			127mm (5")	77mm (3")	■		■			■

SUPERPROX® SM600 SERIES

# Selection Chart

## SM600 Series (cont.)

### Proximity

Model No.	12-24 VDC	Power			Sensing	Range	Window	Transducer	Materials				Standard On/Off N.O. Output	Special N.C. Output	Features
		Cable	Connector	Connection Style					18mm ULTEM®	18mm Stainless	Flat-profile ULTEM®	Special Features			
SM600A-601-00	■	■			152mm (6")	1.6mm (1/16")	■	■				■			
SM600A-601-00FP	■	■			152mm (6")	1.6mm (1/16")	■					■			
SM600A-601-00S	■	■			152mm (6")	1.6mm (1/16")	■					■			
SM600A-601-10	■	■			152mm (6")	1.6mm (1/16")	■	■					■		
SM600A-601-10FP	■	■			152mm (6")	1.6mm (1/16")	■						■		
SM600A-601-10S	■	■			152mm (6")	1.6mm (1/16")	■						■		
SM600A-608-00	■	■			152mm (6")	13mm (1/2")	■	■					■		
SM600A-608-00FP	■	■			152mm (6")	13mm (1/2")	■						■		
SM600A-608-00S	■	■			152mm (6")	13mm (1/2")	■						■		
SM600A-608-10	■	■			152mm (6")	13mm (1/2")	■	■						■	
SM600A-608-10FP	■	■			152mm (6")	13mm (1/2")	■							■	
SM600A-608-10S	■	■			152mm (6")	13mm (1/2")	■							■	
SM600A-612-00	■	■			152mm (6")	19mm (3/4")	■	■						■	
SM600A-612-00FP	■	■			152mm (6")	19mm (3/4")	■							■	
SM600A-612-00S	■	■			152mm (6")	19mm (3/4")	■							■	
SM600A-612-10	■	■			152mm (6")	19mm (3/4")	■	■						■	
SM600A-612-10FP	■	■			152mm (6")	19mm (3/4")	■							■	
SM600A-612-10S	■	■			152mm (6")	19mm (3/4")	■							■	
SM600A-616-00	■	■			152mm (6")	25mm (1")	■	■						■	
SM600A-616-00FP	■	■			152mm (6")	25mm (1")	■							■	
SM600A-616-00S	■	■			152mm (6")	25mm (1")	■							■	
SM600A-616-10	■	■			152mm (6")	25mm (1")	■	■						■	
SM600A-616-10FP	■	■			152mm (6")	25mm (1")	■							■	
SM600A-616-10S	■	■			152mm (6")	25mm (1")	■							■	
SM600A-632-00	■	■			152mm (6")	51mm (2")	■	■						■	
SM600A-632-00FP	■	■			152mm (6")	51mm (2")	■							■	
SM600A-632-00S	■	■			152mm (6")	51mm (2")	■							■	
SM600A-632-10	■	■			152mm (6")	51mm (2")	■	■						■	
SM600A-632-10FP	■	■			152mm (6")	51mm (2")	■							■	
SM600A-632-10S	■	■			152mm (6")	51mm (2")	■							■	
SM600A-648-00	■	■			152mm (6")	77mm (3")	■	■						■	
SM600A-648-00FP	■	■			152mm (6")	77mm (3")	■							■	
SM600A-648-00S	■	■			152mm (6")	77mm (3")	■							■	
SM600A-648-10	■	■			152mm (6")	77mm (3")	■	■						■	
SM600A-648-10FP	■	■			152mm (6")	77mm (3")	■							■	
SM600A-648-10S	■	■			152mm (6")	77mm (3")	■							■	
SM600A-680-00	■	■			152mm (6")	127mm (5")	■	■						■	
SM600A-680-00FP	■	■			152mm (6")	127mm (5")	■							■	
SM600A-680-00S	■	■			152mm (6")	127mm (5")	■							■	
SM600A-680-10•	■	■			152mm (6")	127mm (5")	■	■						■	
SM600A-680-10FP•	■	■			152mm (6")	127mm (5")	■							■	
SM600A-680-10S•	■	■			152mm (6")	127mm (5")	■							■	
SM600A-701-00	■	■			178mm (7")	1.6mm (1/16")	■	■						■	
SM600A-701-00FP	■	■			178mm (7")	1.6mm (1/16")	■							■	
SM600A-701-00S	■	■			178mm (7")	1.6mm (1/16")	■							■	
SM600A-701-10	■	■			178mm (7")	1.6mm (1/16")	■	■						■	
SM600A-701-10FP	■	■			178mm (7")	1.6mm (1/16")	■							■	
SM600A-701-10S	■	■			178mm (7")	1.6mm (1/16")	■							■	
SM600A-708-00	■	■			178mm (7")	13mm (1/2")	■	■						■	
SM600A-708-00FP	■	■			178mm (7")	13mm (1/2")	■							■	
SM600A-708-00S	■	■			178mm (7")	13mm (1/2")	■							■	
SM600A-708-10	■	■			178mm (7")	13mm (1/2")	■	■						■	
SM600A-708-10FP	■	■			178mm (7")	13mm (1/2")	■							■	
SM600A-708-10S	■	■			178mm (7")	13mm (1/2")	■							■	
SM600A-712-00	■	■			178mm (7")	19mm (3/4")	■	■						■	
SM600A-712-00FP	■	■			178mm (7")	19mm (3/4")	■							■	
SM600A-712-00S	■	■			178mm (7")	19mm (3/4")	■							■	
SM600A-712-10	■	■			178mm (7")	19mm (3/4")	■	■						■	
SM600A-712-10FP	■	■			178mm (7")	19mm (3/4")	■							■	
SM600A-712-10S	■	■			178mm (7")	19mm (3/4")	■							■	
SM600A-716-00	■	■			178mm (7")	25mm (1")	■	■						■	
SM600A-716-00FP	■	■			178mm (7")	25mm (1")	■							■	
SM600A-716-00S	■	■			178mm (7")	25mm (1")	■							■	



# Selection Chart

## SM600 Series (cont.) Proximity

Model No.	Power		Connection Style		Range	Window	Transducer	Materials			Special Features	
	12-24 VDC		Cable	Connector				Output Pins Rev	Silicone*	18mm ULTEM®	18mm Stainless	Flat-profile ULTEM®
SM600A-716-10	■	■			178mm (7")	25mm (1")	■	■				■
SM600A-716-10FP	■	■			178mm (7")	25mm (1")	■			■		■
SM600A-716-10S	■	■			178mm (7")	25mm (1")	■		■			■
SM600A-732-00	■	■			178mm (7")	51mm (2")	■	■				■
SM600A-732-00FP	■	■			178mm (7")	51mm (2")	■			■		■
SM600A-732-00S	■	■			178mm (7")	51mm (2")	■		■			■
SM600A-732-10	■	■			178mm (7")	51mm (2")	■	■				■
SM600A-732-10FP	■	■			178mm (7")	51mm (2")	■			■		■
SM600A-732-10S	■	■			178mm (7")	51mm (2")	■		■			■
SM600A-748-00	■	■			178mm (7")	77mm (3")	■	■				■
SM600A-748-00FP	■	■			178mm (7")	77mm (3")	■			■		■
SM600A-748-00S	■	■			178mm (7")	77mm (3")	■		■			■
SM600A-748-10	■	■			178mm (7")	77mm (3")	■	■				■
SM600A-748-10FP	■	■			178mm (7")	77mm (3")	■			■		■
SM600A-748-10S	■	■			178mm (7")	77mm (3")	■		■			■
SM600A-780-00	■	■			178mm (7")	127mm (5")	■	■				■
SM600A-780-00FP	■	■			178mm (7")	127mm (5")	■			■		■
SM600A-780-00S	■	■			178mm (7")	127mm (5")	■		■			■
SM600A-780-10	■	■			178mm (7")	127mm (5")	■	■				■
SM600A-780-10FP	■	■			178mm (7")	127mm (5")	■			■		■
SM600A-780-10S	■	■			178mm (7")	127mm (5")	■		■			■
SM650A-201-00	■	■	■		51mm (2")	1.6mm (1/16")	■	■				■
SM650A-201-00FP	■	■	■		51mm (2")	1.6mm (1/16")	■			■		■
SM650A-201-00S	■	■	■		51mm (2")	1.6mm (1/16")	■		■			■
SM650A-201-10	■	■	■		51mm (2")	1.6mm (1/16")	■	■				■
SM650A-201-10FP	■	■	■		51mm (2")	1.6mm (1/16")	■			■		■
SM650A-201-10S	■	■	■		51mm (2")	1.6mm (1/16")	■		■			■
SM650A-208-00	■	■	■		51mm (2")	13mm (1/2")	■	■				■
SM650A-208-00FP	■	■	■		51mm (2")	13mm (1/2")	■			■		■
SM650A-208-00S	■	■	■		51mm (2")	13mm (1/2")	■		■			■
SM650A-208-10	■	■	■		51mm (2")	13mm (1/2")	■	■				■
SM650A-208-10FP	■	■	■		51mm (2")	13mm (1/2")	■			■		■
SM650A-208-10S	■	■	■		51mm (2")	13mm (1/2")	■		■			■
SM650A-212-00	■	■	■		51mm (2")	19mm (3/4")	■	■				■
SM650A-212-00FP	■	■	■		51mm (2")	19mm (3/4")	■			■		■
SM650A-212-00S	■	■	■		51mm (2")	19mm (3/4")	■		■			■
SM650A-212-10	■	■	■		51mm (2")	19mm (3/4")	■	■				■
SM650A-212-10FP	■	■	■		51mm (2")	19mm (3/4")	■			■		■
SM650A-212-10S	■	■	■		51mm (2")	19mm (3/4")	■		■			■
SM650A-216-00•	■	■	■		51mm (2")	25mm (1")	■	■				■
SM650A-216-00FP•	■	■	■		51mm (2")	25mm (1")	■			■		■
SM650A-216-00S•	■	■	■		51mm (2")	25mm (1")	■		■			■
SM650A-216-10	■	■	■		51mm (2")	25mm (1")	■	■				■
SM650A-216-10FP	■	■	■		51mm (2")	25mm (1")	■			■		■
SM650A-216-10S	■	■	■		51mm (2")	25mm (1")	■		■			■
SM650A-301-00	■	■	■		77mm (3")	1.6mm (1/16")	■	■				■
SM650A-301-00FP	■	■	■		77mm (3")	1.6mm (1/16")	■			■		■
SM650A-301-00S	■	■	■		77mm (3")	1.6mm (1/16")	■		■			■
SM650A-301-10	■	■	■		77mm (3")	1.6mm (1/16")	■	■				■
SM650A-301-10FP	■	■	■		77mm (3")	1.6mm (1/16")	■			■		■
SM650A-301-10S	■	■	■		77mm (3")	1.6mm (1/16")	■		■			■
SM650A-308-00	■	■	■		77mm (3")	13mm (1/2")	■	■				■
SM650A-308-00FP	■	■	■		77mm (3")	13mm (1/2")	■			■		■
SM650A-308-00S	■	■	■		77mm (3")	13mm (1/2")	■		■			■
SM650A-308-10	■	■	■		77mm (3")	13mm (1/2")	■	■				■
SM650A-308-10FP	■	■	■		77mm (3")	13mm (1/2")	■			■		■
SM650A-308-10S	■	■	■		77mm (3")	13mm (1/2")	■		■			■
SM650A-312-00	■	■	■		77mm (3")	19mm (3/4")	■	■				■
SM650A-312-00FP	■	■	■		77mm (3")	19mm (3/4")	■			■		■
SM650A-312-00S	■	■	■		77mm (3")	19mm (3/4")	■		■			■
SM650A-312-10	■	■	■		77mm (3")	19mm (3/4")	■	■				■
SM650A-312-10FP	■	■	■		77mm (3")	19mm (3/4")	■			■		■
SM650A-312-10S	■	■	■		77mm (3")	19mm (3/4")	■		■			■

SUPERPROX® SM600 SERIES

# Selection Chart

## SM600 Series (cont.)

### Proximity

Model No.	12-24 VDC	Cable	Connection Style	Output Pins Rev	Sensing		Transducer	Materials			Special Features
					Range	Window		Silicone*	18mm ULTEM®	18mm Stainless	
SM650A-316-00	■	■	■		77mm (3")	25mm (1")	■	■			
SM650A-316-00FP	■	■	■		77mm (3")	25mm (1")	■		■	■	
SM650A-316-00S	■	■	■		77mm (3")	25mm (1")	■	■		■	
SM650A-316-10	■	■	■		77mm (3")	25mm (1")	■	■			■
SM650A-316-10FP	■	■	■		77mm (3")	25mm (1")	■		■		■
SM650A-316-10S	■	■	■		77mm (3")	25mm (1")	■	■			■
SM650A-332-00	■	■	■		77mm (3")	51mm (2")	■	■		■	
SM650A-332-00FP	■	■	■		77mm (3")	51mm (2")	■		■	■	
SM650A-332-00S	■	■	■		77mm (3")	51mm (2")	■	■		■	
SM650A-332-10	■	■	■		77mm (3")	51mm (2")	■	■			■
SM650A-332-10FP	■	■	■		77mm (3")	51mm (2")	■		■		■
SM650A-332-10S	■	■	■		77mm (3")	51mm (2")	■	■			■
SM650A-401-00	■	■	■		102mm (4")	1.6mm (1/16")	■	■		■	
SM650A-401-00FP	■	■	■		102mm (4")	1.6mm (1/16")	■		■	■	
SM650A-401-00S	■	■	■		102mm (4")	1.6mm (1/16")	■	■		■	
SM650A-401-10	■	■	■		102mm (4")	1.6mm (1/16")	■	■			■
SM650A-401-10FP	■	■	■		102mm (4")	1.6mm (1/16")	■		■		■
SM650A-401-10S	■	■	■		102mm (4")	1.6mm (1/16")	■	■			■
SM650A-408-00	■	■	■		102mm (4")	13mm (1/2")	■	■		■	
SM650A-408-00FP	■	■	■		102mm (4")	13mm (1/2")	■		■	■	
SM650A-408-00S	■	■	■		102mm (4")	13mm (1/2")	■	■		■	
SM650A-408-10	■	■	■		102mm (4")	13mm (1/2")	■	■			■
SM650A-408-10FP	■	■	■		102mm (4")	13mm (1/2")	■		■		■
SM650A-408-10S	■	■	■		102mm (4")	13mm (1/2")	■	■			■
SM650A-412-00	■	■	■		102mm (4")	19mm (3/4")	■	■		■	
SM650A-412-00FP	■	■	■		102mm (4")	19mm (3/4")	■		■	■	
SM650A-412-00S	■	■	■		102mm (4")	19mm (3/4")	■	■		■	
SM650A-412-10	■	■	■		102mm (4")	19mm (3/4")	■	■			■
SM650A-412-10FP	■	■	■		102mm (4")	19mm (3/4")	■		■		■
SM650A-412-10S	■	■	■		102mm (4")	19mm (3/4")	■	■			■
SM650A-416-00	■	■	■		102mm (4")	25mm (1")	■	■		■	
SM650A-416-00FP	■	■	■		102mm (4")	25mm (1")	■		■	■	
SM650A-416-00S	■	■	■		102mm (4")	25mm (1")	■	■		■	
SM650A-416-10	■	■	■		102mm (4")	25mm (1")	■	■			■
SM650A-416-10FP	■	■	■		102mm (4")	25mm (1")	■		■		■
SM650A-416-10S	■	■	■		102mm (4")	25mm (1")	■	■			■
SM650A-432-00	■	■	■		102mm (4")	51mm (2")	■	■		■	
SM650A-432-00FP	■	■	■		102mm (4")	51mm (2")	■		■	■	
SM650A-432-00S	■	■	■		102mm (4")	51mm (2")	■	■		■	
SM650A-432-10	■	■	■		102mm (4")	51mm (2")	■	■			■
SM650A-432-10FP	■	■	■		102mm (4")	51mm (2")	■		■		■
SM650A-432-10S	■	■	■		102mm (4")	51mm (2")	■	■			■
SM650A-448-00•	■	■	■		102mm (4")	77mm (3")	■	■		■	
SM650A-448-00FP•	■	■	■		102mm (4")	77mm (3")	■		■	■	
SM650A-448-00S•	■	■	■		102mm (4")	77mm (3")	■	■		■	
SM650A-448-10	■	■	■		102mm (4")	77mm (3")	■	■			■
SM650A-448-10FP	■	■	■		102mm (4")	77mm (3")	■		■		■
SM650A-448-10S	■	■	■		102mm (4")	77mm (3")	■	■			■
SM650A-501-00	■	■	■		127mm (5")	1.6mm (1/16")	■	■		■	
SM650A-501-00FP	■	■	■		127mm (5")	1.6mm (1/16")	■		■	■	
SM650A-501-00S	■	■	■		127mm (5")	1.6mm (1/16")	■	■		■	
SM650A-501-10	■	■	■		127mm (5")	1.6mm (1/16")	■	■			■
SM650A-501-10FP	■	■	■		127mm (5")	1.6mm (1/16")	■		■		■
SM650A-501-10S	■	■	■		127mm (5")	1.6mm (1/16")	■	■			■
SM650A-508-00	■	■	■		127mm (5")	13mm (1/2")	■	■		■	
SM650A-508-00FP	■	■	■		127mm (5")	13mm (1/2")	■		■	■	
SM650A-508-00S	■	■	■		127mm (5")	13mm (1/2")	■	■		■	
SM650A-508-10	■	■	■		127mm (5")	13mm (1/2")	■	■			■
SM650A-508-10FP	■	■	■		127mm (5")	13mm (1/2")	■		■		■
SM650A-508-10S	■	■	■		127mm (5")	13mm (1/2")	■	■			■
SM650A-512-00	■	■	■		127mm (5")	19mm (3/4")	■	■		■	
SM650A-512-00FP	■	■	■		127mm (5")	19mm (3/4")	■		■	■	
SM650A-512-00S	■	■	■		127mm (5")	19mm (3/4")	■	■		■	

# Selection Chart

## SM600 Series (cont.) Proximity

Model No.	Power 12-24 VDC	Cable	Connection Style		Range	Window	Transducer Silicone*	Materials			Special Features
			Connector	Connector Output Pins Rev				18mm ULTEM®*	18mm Stainless	Flat-profile ULTEM®	
SM650A-512-10	■	■	■	■	127mm (5")	19mm (3/4")	■	■			■
SM650A-512-10FP	■	■	■	■	127mm (5")	19mm (3/4")	■			■	■
SM650A-512-10S	■	■	■	■	127mm (5")	19mm (3/4")	■		■		■
SM650A-516-00	■	■	■	■	127mm (5")	25mm (1")	■	■			■
SM650A-516-00FP	■	■	■	■	127mm (5")	25mm (1")	■			■	■
SM650A-516-00S	■	■	■	■	127mm (5")	25mm (1")	■		■		■
SM650A-516-10	■	■	■	■	127mm (5")	25mm (1")	■	■			■
SM650A-516-10FP	■	■	■	■	127mm (5")	25mm (1")	■			■	■
SM650A-516-10S	■	■	■	■	127mm (5")	25mm (1")	■		■		■
SM650A-532-00	■	■	■	■	127mm (5")	51mm (2")	■	■			■
SM650A-532-00FP	■	■	■	■	127mm (5")	51mm (2")	■			■	■
SM650A-532-00S	■	■	■	■	127mm (5")	51mm (2")	■		■		■
SM650A-532-10	■	■	■	■	127mm (5")	51mm (2")	■	■			■
SM650A-532-10FP	■	■	■	■	127mm (5")	51mm (2")	■			■	■
SM650A-532-10S	■	■	■	■	127mm (5")	51mm (2")	■		■		■
SM650A-548-00	■	■	■	■	127mm (5")	77mm (3")	■	■			■
SM650A-548-00FP	■	■	■	■	127mm (5")	77mm (3")	■			■	■
SM650A-548-00S	■	■	■	■	127mm (5")	77mm (3")	■		■		■
SM650A-548-10	■	■	■	■	127mm (5")	77mm (3")	■	■			■
SM650A-548-10FP	■	■	■	■	127mm (5")	77mm (3")	■			■	■
SM650A-548-10S	■	■	■	■	127mm (5")	77mm (3")	■		■		■
SM650A-601-00	■	■	■	■	152mm (6")	1.6mm (1/16")	■	■			■
SM650A-601-00FP	■	■	■	■	152mm (6")	1.6mm (1/16")	■			■	■
SM650A-601-00S	■	■	■	■	152mm (6")	1.6mm (1/16")	■		■		■
SM650A-601-10	■	■	■	■	152mm (6")	1.6mm (1/16")	■	■			■
SM650A-601-10FP	■	■	■	■	152mm (6")	1.6mm (1/16")	■			■	■
SM650A-601-10S	■	■	■	■	152mm (6")	1.6mm (1/16")	■		■		■
SM650A-608-00	■	■	■	■	152mm (6")	13mm (1/2")	■	■			■
SM650A-608-00FP	■	■	■	■	152mm (6")	13mm (1/2")	■			■	■
SM650A-608-00S	■	■	■	■	152mm (6")	13mm (1/2")	■		■		■
SM650A-608-10	■	■	■	■	152mm (6")	13mm (1/2")	■	■			■
SM650A-608-10FP	■	■	■	■	152mm (6")	13mm (1/2")	■			■	■
SM650A-608-10S	■	■	■	■	152mm (6")	13mm (1/2")	■		■		■
SM650A-612-00	■	■	■	■	152mm (6")	19mm (3/4")	■	■			■
SM650A-612-00FP	■	■	■	■	152mm (6")	19mm (3/4")	■			■	■
SM650A-612-00S	■	■	■	■	152mm (6")	19mm (3/4")	■		■		■
SM650A-612-10	■	■	■	■	152mm (6")	19mm (3/4")	■	■			■
SM650A-612-10FP	■	■	■	■	152mm (6")	19mm (3/4")	■			■	■
SM650A-612-10S	■	■	■	■	152mm (6")	19mm (3/4")	■		■		■
SM650A-616-00	■	■	■	■	152mm (6")	25mm (1")	■	■			■
SM650A-616-00FP	■	■	■	■	152mm (6")	25mm (1")	■			■	■
SM650A-616-00S	■	■	■	■	152mm (6")	25mm (1")	■		■		■
SM650A-616-10	■	■	■	■	152mm (6")	25mm (1")	■	■			■
SM650A-616-10FP	■	■	■	■	152mm (6")	25mm (1")	■			■	■
SM650A-616-10S	■	■	■	■	152mm (6")	25mm (1")	■		■		■
SM650A-632-00	■	■	■	■	152mm (6")	51mm (2")	■	■			■
SM650A-632-00FP	■	■	■	■	152mm (6")	51mm (2")	■			■	■
SM650A-632-00S	■	■	■	■	152mm (6")	51mm (2")	■		■		■
SM650A-632-10	■	■	■	■	152mm (6")	51mm (2")	■	■			■
SM650A-632-10FP	■	■	■	■	152mm (6")	51mm (2")	■			■	■
SM650A-632-10S	■	■	■	■	152mm (6")	51mm (2")	■		■		■
SM650A-648-00	■	■	■	■	152mm (6")	77mm (3")	■	■			■
SM650A-648-00FP	■	■	■	■	152mm (6")	77mm (3")	■			■	■
SM650A-648-00S	■	■	■	■	152mm (6")	77mm (3")	■		■		■
SM650A-648-10	■	■	■	■	152mm (6")	77mm (3")	■	■			■
SM650A-648-10FP	■	■	■	■	152mm (6")	77mm (3")	■			■	■
SM650A-648-10S	■	■	■	■	152mm (6")	77mm (3")	■		■		■
SM650A-680-00•	■	■	■	■	152mm (6")	127mm (5")	■	■			■
SM650A-680-00FP•	■	■	■	■	152mm (6")	127mm (5")	■			■	■
SM650A-680-00S•	■	■	■	■	152mm (6")	127mm (5")	■		■		■
SM650A-680-10	■	■	■	■	152mm (6")	127mm (5")	■	■			■
SM650A-680-10FP	■	■	■	■	152mm (6")	127mm (5")	■			■	■
SM650A-680-10S	■	■	■	■	152mm (6")	127mm (5")	■		■		■

SUPERPROX® SM600 SERIES

# Selection Chart

## SM600 Series (cont.)

### Proximity

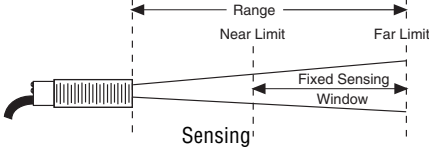
Model No.	Power		Connection Style		Sensing <sup>1</sup>	Range	Window	Transducer	Materials			Special Features	
	12-24 VDC		Cable	Connector					Output Pins Rev	Silicone*	18mm ULTEM®*	18mm Stainless	Flat-profile ULTEM®
SM650A-701-00	■		■			178mm (7")	1.6mm (1/16")	■	■			■	
SM650A-701-00FP	■		■			178mm (7")	1.6mm (1/16")	■				■	
SM650A-701-00S	■		■			178mm (7")	1.6mm (1/16")	■		■			
SM650A-701-10	■		■			178mm (7")	1.6mm (1/16")	■	■				■
SM650A-701-10FP	■		■			178mm (7")	1.6mm (1/16")	■					■
SM650A-701-10S	■		■			178mm (7")	1.6mm (1/16")	■		■			■
SM650A-708-00	■		■			178mm (7")	13mm (1/2")	■	■				
SM650A-708-00FP	■		■			178mm (7")	13mm (1/2")	■					
SM650A-708-00S	■		■			178mm (7")	13mm (1/2")	■		■			
SM650A-708-10	■		■			178mm (7")	13mm (1/2")	■	■				■
SM650A-708-10FP	■		■			178mm (7")	13mm (1/2")	■					■
SM650A-708-10S	■		■			178mm (7")	13mm (1/2")	■		■			■
SM650A-712-00	■		■			178mm (7")	19mm (3/4")	■	■				
SM650A-712-00FP	■		■			178mm (7")	19mm (3/4")	■					
SM650A-712-00S	■		■			178mm (7")	19mm (3/4")	■		■			
SM650A-712-10	■		■			178mm (7")	19mm (3/4")	■	■				■
SM650A-712-10FP	■		■			178mm (7")	19mm (3/4")	■					■
SM650A-712-10S	■		■			178mm (7")	19mm (3/4")	■		■			■
SM650A-716-00	■		■			178mm (7")	25mm (1")	■	■				
SM650A-716-00FP	■		■			178mm (7")	25mm (1")	■					
SM650A-716-00S	■		■			178mm (7")	25mm (1")	■		■			
SM650A-716-10	■		■			178mm (7")	25mm (1")	■	■				■
SM650A-716-10FP	■		■			178mm (7")	25mm (1")	■					■
SM650A-716-10S	■		■			178mm (7")	25mm (1")	■		■			■
SM650A-732-00	■		■			178mm (7")	51mm (2")	■	■				
SM650A-732-00FP	■		■			178mm (7")	51mm (2")	■					
SM650A-732-00S	■		■			178mm (7")	51mm (2")	■		■			
SM650A-732-10	■		■			178mm (7")	51mm (2")	■	■				■
SM650A-732-10FP	■		■			178mm (7")	51mm (2")	■					■
SM650A-732-10S	■		■			178mm (7")	51mm (2")	■		■			■
SM650A-748-00	■		■			178mm (7")	77mm (3")	■	■				
SM650A-748-00FP	■		■			178mm (7")	77mm (3")	■					
SM650A-748-00S	■		■			178mm (7")	77mm (3")	■		■			
SM650A-748-10	■		■			178mm (7")	77mm (3")	■	■				■
SM650A-748-10FP	■		■			178mm (7")	77mm (3")	■					■
SM650A-748-10S	■		■			178mm (7")	77mm (3")	■		■			■
SM650A-780-00	■		■			178mm (7")	127mm (5")	■	■				
SM650A-780-00FP	■		■			178mm (7")	127mm (5")	■					
SM650A-780-00S	■		■			178mm (7")	127mm (5")	■		■			
SM650A-780-10	■		■			178mm (7")	127mm (5")	■	■				■
SM650A-780-10FP	■		■			178mm (7")	127mm (5")	■					■
SM650A-780-10S	■		■			178mm (7")	127mm (5")	■		■			■

• = Most commonly stocked sensors

\* = See definition in *Sensing Terms*.

All possible sensor configurations are not listed here.

## SUPERPROX® Ultrasonic Dual-Level Sensors



CE

**Two styles of reliable ultrasonic sensors offer short range sensing solutions for dual-level control applications where mounting space is very limited**

Functionality of the versatile, industry-proven SUPERPROX® Model SM502 series is now part of the Model SM602 series of 18 mm or flat-profile, dual-level sensors. Utilizing the same world-leading, ultrasonic technology, these two styles of “smart” sensors can be selected for specific on/off latch or dual-alarm control functions. Other model selections include a variety of output types, response times, sensing ranges, and functionality to provide the sensing solution for a wide assortment of noncontact, short-range, dual-level control applications.

### Operation

Hyde Park’s 18 mm barrel and flat-profile style of self-contained, dual-level sensors monitor and control most nonhazardous liquid or dry material levels within a sensing range of 25.4 mm (1”) to 254 mm (10”). When selecting by model number from several factory-programmed, dual-limit parameters (near limit and far limit), the sensor can be set up to perform either an on/off latch or a dual-alarm control function.

The 18 mm threaded barrel-style housing is available in either ULTEM® plastic or SS303 stainless steel while the flat-profile housing is available in ULTEM® plastic only. Both provide ease-of-installation convenience, particularly in applications with hard-to-mount or limited-space mounting areas. All models in this sensor series operate on 12 to 24 VDC regulated power.

For sensing applications requiring connection to a DeviceNet network, the flat-profile models in this series are available

- High resolution 500 kHz ultrasonic frequency
- Self-contained, 18 mm barrel or flat-profile housing styles
- Dual-level on/off latch
- Field programmable capability in 18 mm and flat-profile models
- DeviceNet capability available in flat-profile models
- CE certified

with this capability as an optional selection.

The Model SM602 sensor series offers dependable operation and compatible integration with most programmable logic controllers. Each sensor is epoxy sealed to withstand harsh, wet, messy, and dusty environments typically associated with level-control applications. With protection ratings of NEMA 4X and IP67, both sensor styles are impervious to changing light conditions, colors, noise, noncondensing humidity, caustic chemicals, and other hostile environments. They are resistant to most acids and bases, including most food products. The SS303 stainless steel, 18 mm housing allows application use where USDA-3A sanitary compliance is required. The sensing transducer is made of silicone rubber and the sensors carry the CE mark.

## How does it work?

During setup and operation, these SM602 series sensors continually and accurately measure the elapsed time of every pulse echo reception between each pulse transmission. The transmitted pulse begins a time clock to register the elapsed times for the received pulse echoes. Given the elapsed time, the sensor software calculates the distance traveled out to the object or surface and back to the sensor, using the formula,  $D = TV_s/2$ , where:  
 $D$  = distance from the sensor to the object;  
 $T$  = elapsed time between the pulse transmission and its echo receptions,  
 $V_s$  = the velocity of sound, approximately 1100 feet per second.

During operation, the calculated distance ( $D$ ) between the sensor and the object (e.g., level) is compared to the distance between the sensor and the near and far span limits. These limits are shown in the illustration at right as  $D_{wi}$  and  $D_{wo}$ . When  $D$  is equal to one of the two span limits, according to the level-control functions, an output change takes place.

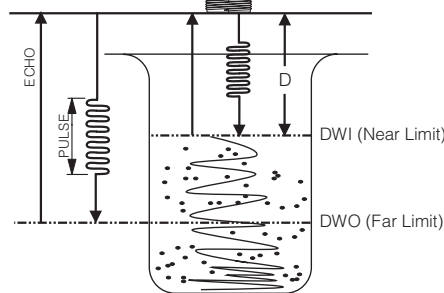

## Level-Control Functions

The level-control output in the Model SM602 series can be configured for one of three different operating functions. Using the Model Reference Guide, the sensor can be selected to perform either a pump-in level-control function, pump-out level-control function or a dual alarm level-control function.

### Pump-in Level Control

When the level moves beyond the far limit, the sensor level control output switches state and latches, starting a pump-in process. The sensor level control output does not change state until the level moves back beyond the near limit to stop the pumping or filling process.

### Pump-out Level Control

When the level moves beyond the far limit, the level control output switches state and latches, stopping a pump-out process. The sensor level control output

## Model Reference Guide - SM602 Series

Both the cable and connector style sensors are available in various models. Use the guide below to select or order the sensor to ensure the correct model number is specified for the application.

### EXAMPLE MODEL:

**SM6 0 2 A - 6 04 - 10**

#### SUPERPROX® Product Series

#### Power/Connection Type

0...12 to 24 VDC / cable style

5...12 to 24 VDC / "micro" connector style

#### Sensing Type

2...Dual point

#### Design Level

A...Applies to all models

#### Far Limit/Alarm

4...102 mm (4")

5...127 mm (5")

6...152 mm (6")

B...254 mm (10"), maximum

#### Near Limit/Alarm

**(Distance from Far Limit/Alarm to Near Limit/Alarm)\*\***

04...6.4 mm (1/4")

06...9.5 mm (3/8")

16...25 mm (1")

32...51 mm (2")

OB...203 mm (8")

#### Functionality

00...Pump-out latch

03...Pump-out latch with loss of echo

10...Pump-in latch

13...Pump-in latch with loss of echo

20...Dual alarm, normally open (N.O.)

23...Dual alarm, normally open (N.O.) with loss of echo

30...Dual alarm, normally closed (N.C.)

33...Dual alarm, normally closed (N.C.) with loss of echo

[Contact the factory for additional functionality options]

#### Options

Contact the factory for available options

#### Housing Types

...No letter indicates standard ULTEM® plastic - 18 mm barrel housing

FP...ULTEM® flat-profile housing

S...SS303 stainless steel - 18 mm barrel housing

NOTE: Contact the factory for DeviceNet communications capability in the flat-profile models

\* ULTEM® is a registered trademark of The General Electric Company.

\*\*Not allowed inside the 1.25" deadband, using standard gain sensor

does not change state until the level moves back beyond the near limit to restart the pump-out process.

### Dual-Alarm Level Control

The far alarm output switches when an object moves beyond the far alarm limit

and changes state when an object returns closer than the far alarm limit.

The near alarm output switches when an object moves closer than the near alarm limit and changes state when an object returns beyond the near alarm limit.

## Sensor Operating Profiles

### Pump-in Level Control

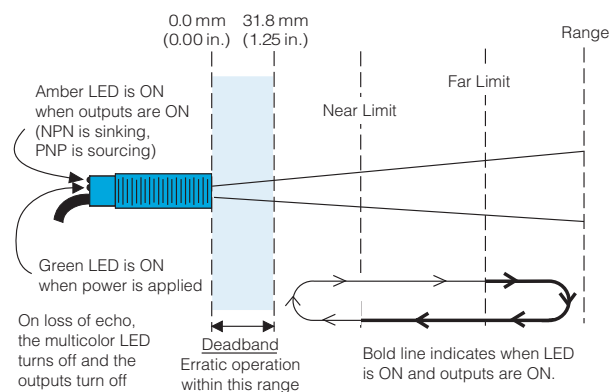

## Sensor Operating Profiles (cont.)

### Pump-out Level Control

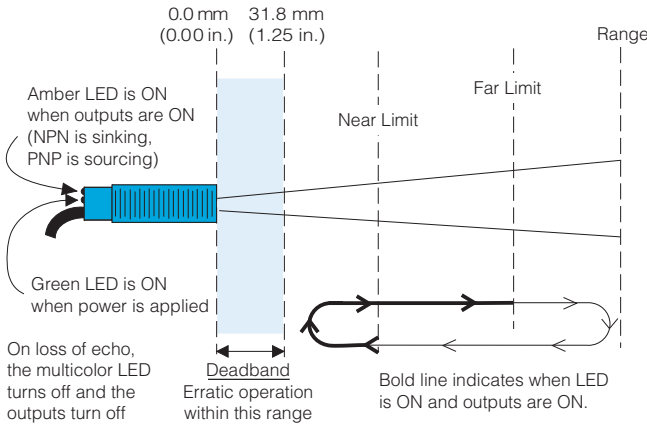

### Alarm Level Control

Normally Open Outputs Operation

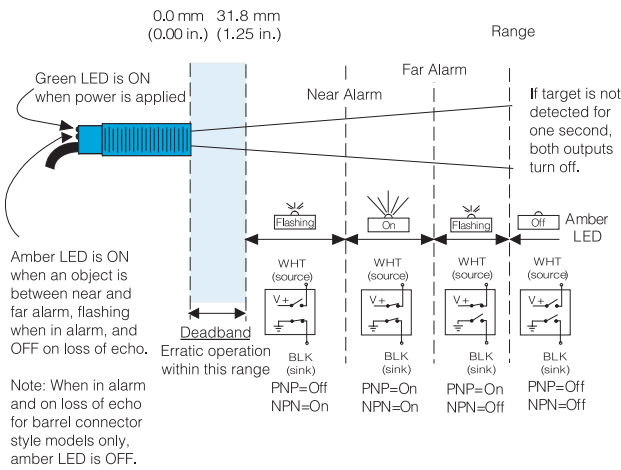

Normally Closed Outputs Operation

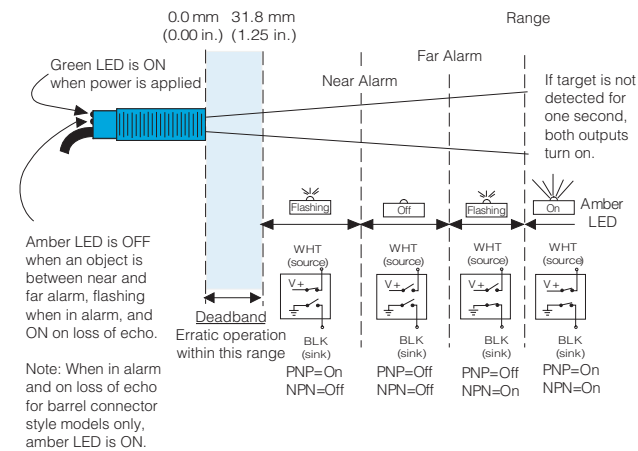

## Loss of Echo Operation

### Output Off on Loss of Echo

Loss of echo occurs when the sensor does not receive echoes from an object within its sensing range for more than one second. When this occurs, the sensor's output automatically switches OFF. When the sensor again receives echoes, the output assumes the state relative to the control limit setpoints.

The only exception applies to the alarm level control models with

normally closed outputs as shown and noted in the illustration.

### Output Holds on Loss of Echo ("LE" Option)

The LE suffix indicates an available option for users who do not prefer the standard response to loss of echo. With the LE option, when loss of echo occurs, there is no change in the output state of the sensor. When the sensor again receives echoes, the output assumes the state relative to the control limit setpoints.

## Mounting

The Model SM602 series sensors should be mounted in brackets that allow them to be adjusted for proper alignment. Hyde Park offers the Model AC226 stainless and polyamide conveyor-rail clamp/bracket set, Model AC227 large, right-angle, stainless mounting bracket, Model AC228 small, right-angle, stainless, mounting bracket, Model AC231 straight, stainless, mounting bracket and Model AC232 s-shaped, stainless, mounting bracket. All are illustrated with dimensions on Pages 4-89 and 4-90.

## Electrical Wiring

The sensor wires must be run in conduit free of any AC power or control wires.

### Cable Model Wire Assignments

On/Off Latch Outputs

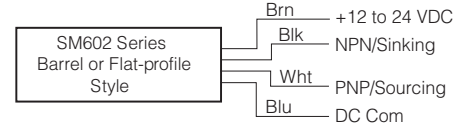

Dual Alarm Outputs

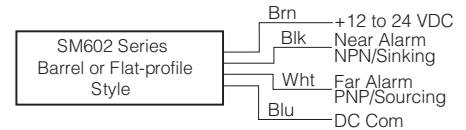

### Connector Model Pin Assignments

On/Off Latch Outputs

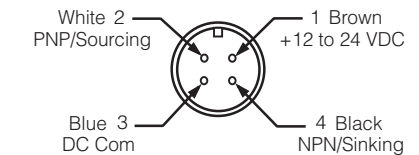

Dual Alarm Outputs

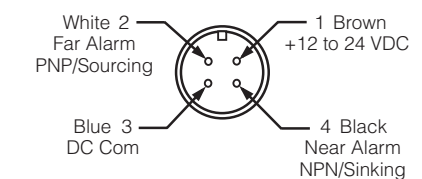

### NPN/Sinking and PNP/Sourcing Outputs

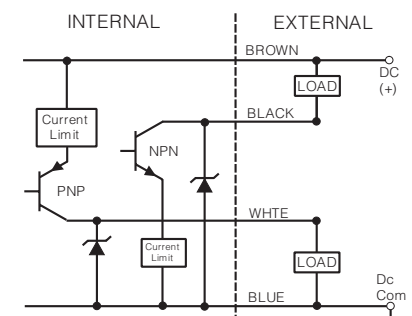

## Dimensions

### Barrel Cable Style

(ULTEM® plastic and stainless steel) SM602A-XXX-XX, SM602A-XXX-XXS

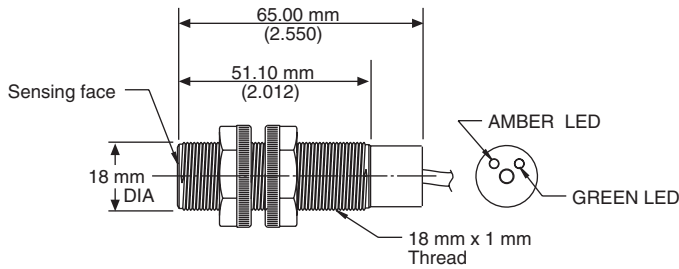

### Barrel Connector Style

(ULTEM® plastic and stainless steel) SM652A-XXX-XX, SM652A-XXX-XXS

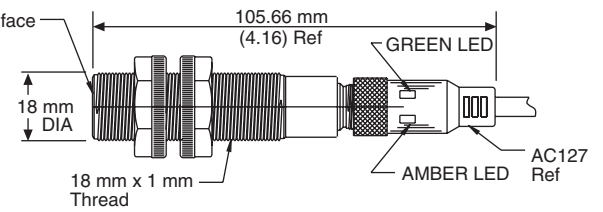
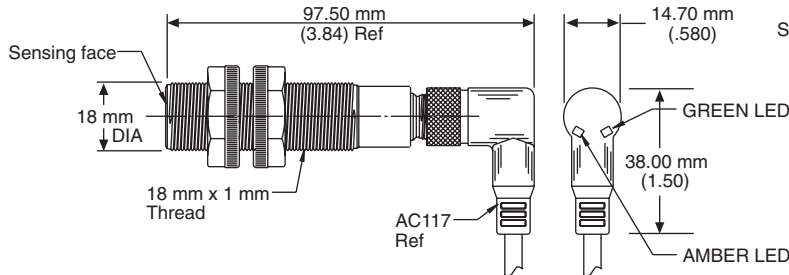
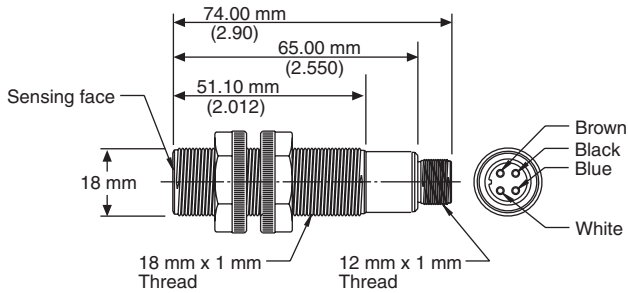

### “Flat-profile” Cable Style

(ULTEM® plastic) SM602A-XXX-XXFP

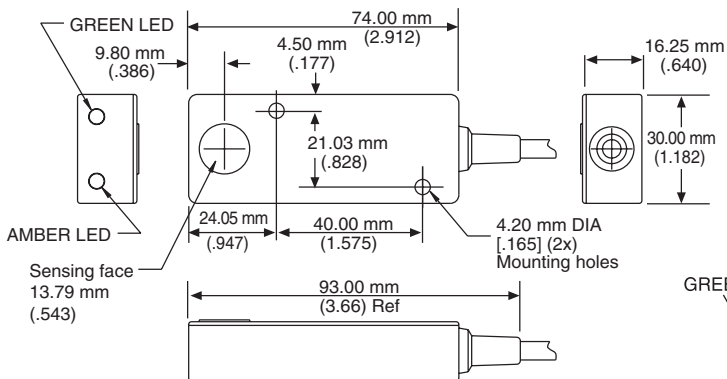

### “Flat-profile” Connector Style

(ULTEM® plastic) SM652A-XXX-XXFP

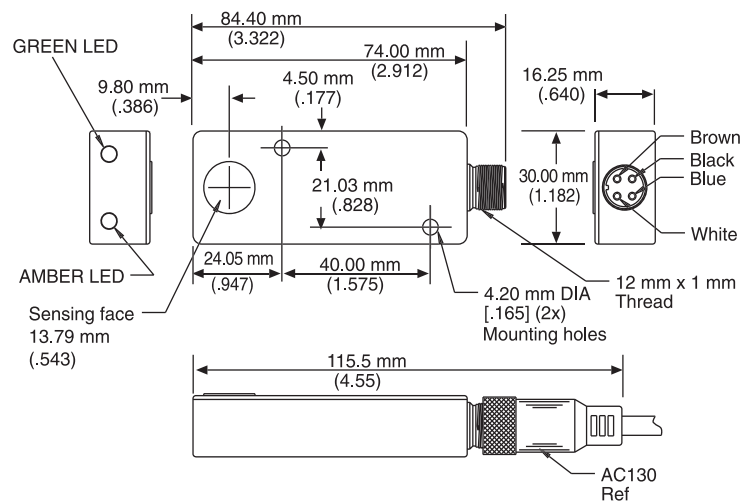



## Mounting Accessories

**AC117** Right-angle, M12 micro, 4-conductor, connector/cable assembly, 5 m (16'), with built-in LEDs (for barrel connector-style sensors)

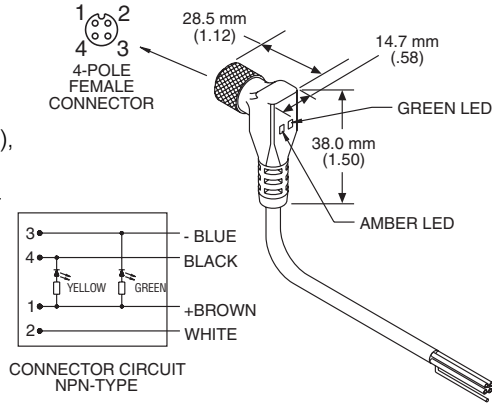

**AC127** Straight, M12 micro, 4-conductor, connector/cable assembly, 5 m (16'), with built-in LEDs (for barrel connector-style sensors)

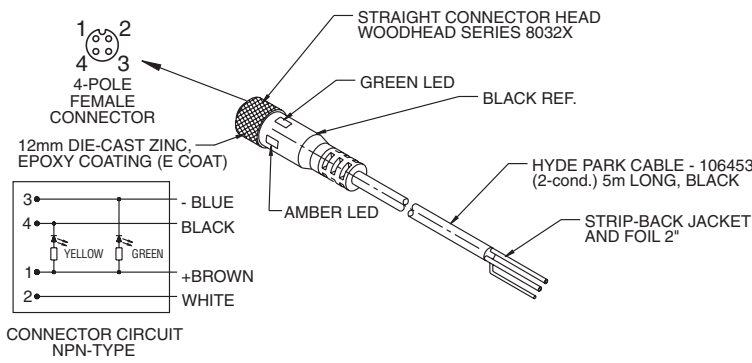

**AC130** Straight, M12 micro, 4-conductor, connector/cable assembly, 5 m (16') (for flat-profile connector-style sensors)

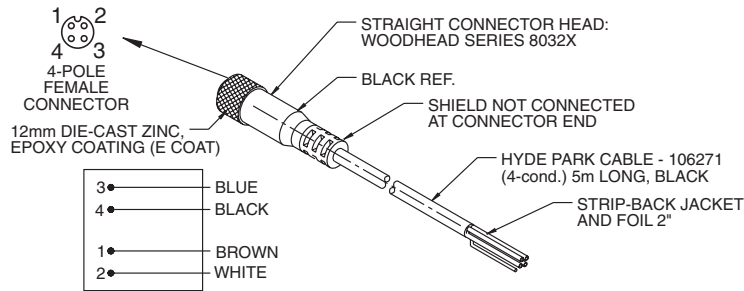

**AC132** Right-angle, M12 micro, 4-conductor, connector/cable assembly, 5 m (16') (for flat-profile connector-style sensors)

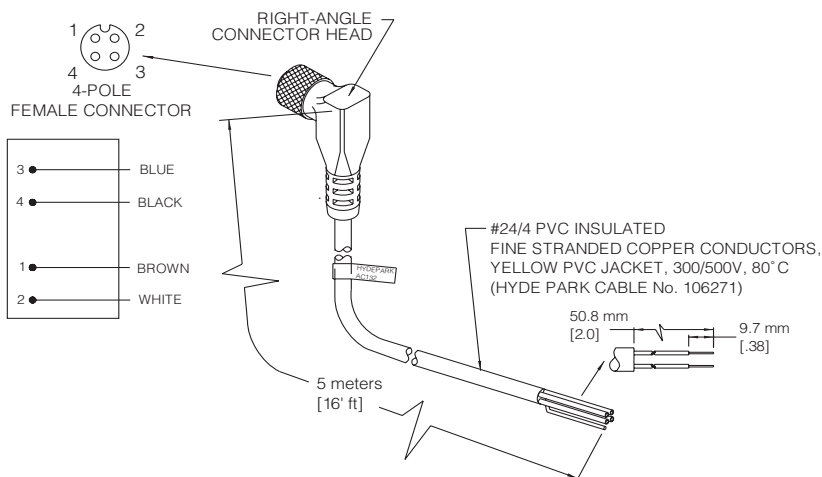

**AC226** Stainless and polyamide conveyor-rail clamp/bracket set (for 18 mm barrel sensors)

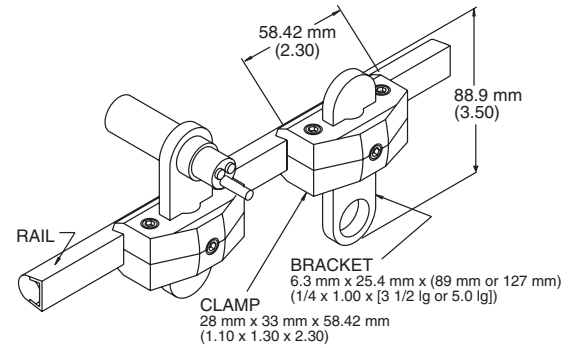

**AC227** Large, right-angle, stainless, mounting bracket (for 18 mm barrel sensors)

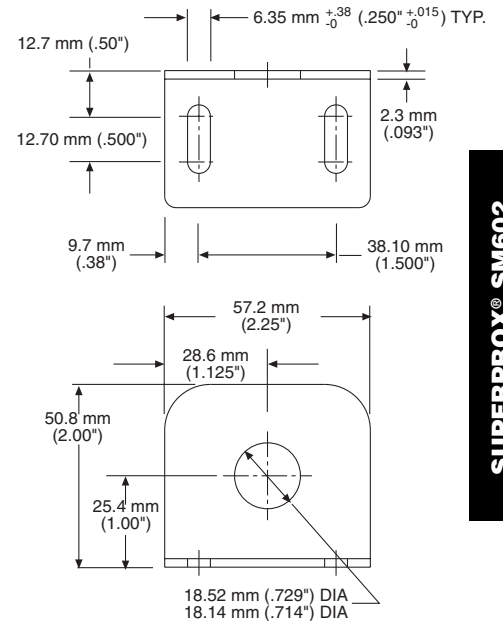

**AC228** Small, right-angle, stainless, mounting bracket (for 18 mm barrel sensors)

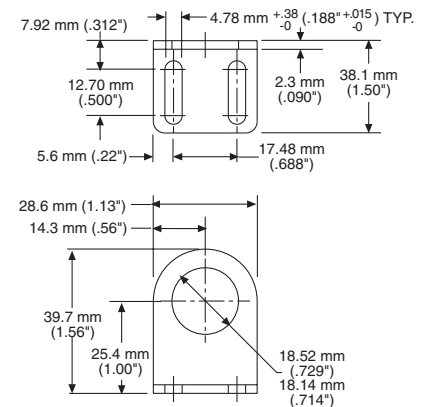

SUPERPROX® SM602 SERIES

**AC231** Straight, stainless mounting bracket (for flat-profile sensors)

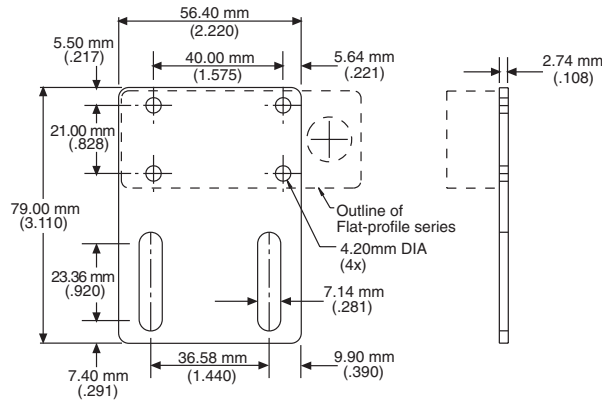

**AC232** S-shaped, stainless mounting bracket (for flat-profile sensors)

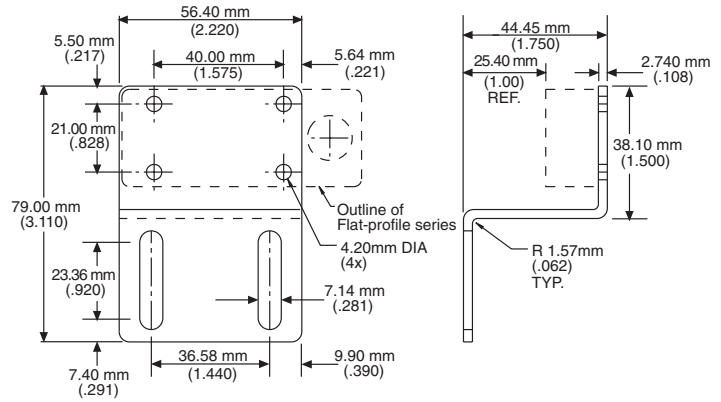

**General Specifications**

**Sensing**

- Ranges:
  - Up to 254 mm (10")
- Spans:
  - From 3.18 mm (1/8") to 228.6 mm (9")
- Window Position, Initial Accuracy:
  - ± 1.59 mm (0.062") max.
- Window Position Repeatability:
  - ± 0.69 mm (0.027") max.
- Detection Benchmarks:
  - Models with Ranges to 177.8 mm (7"):
    - 1.59 mm (1/6") diameter rod at a distance of 63.5 mm (2.5")
    - Max. ±10° tilt of large flat object at a distance of 127 mm (5")
  - Models with Ranges from over 177.8 mm (7") to 254 mm (10"):
    - 1.59 mm (1/6") diameter rod at a distance of 76.2 mm (3")
    - Max. ± 10° tilt of large flat object at a distance of 203.2 mm (8")
- Sonic Frequency: 500 kHz
- Sonic Cone Angle: 7° (see beam plot, page 4-72)

**Power Requirements**

- Supply Voltage:
  - 12 to 24 VDC ± 10%, regulated supply
- Current Consumption:
  - Cable Model: 50 mA max. (excluding load)
  - Connector Model: 60 mA max. (excluding load)
- Power Consumption:
  - 1.0 W max. (excluding load)

**Output**

- NPN Sinking: 0 to 30 V
- Maximum on-state voltage at 100 mA: 0.2 volts
- PNP Sourcing: 100 mA @ 24 VDC, max.

**Response Time**

- "On" 3 ms, "Off" 3 ms (standard)
- "On" 1.5 ms, "Off" 1.5 ms (optional)

**Indicators**

- Green LED: Power "On"
- Amber LED:
  - Cable model: "On" if object is detected within the window, regardless of output polarity (N.O./N.C.) style.
  - Connector model with built-in cable LEDs: "On" if NPN output is sinking

**Connections**

- Cable Style Models:
  - 24 AWG, foil shield, lead-free, PVC jacket
  - 4-conductor, 3 meters (10') long
- Connector Style Models:
  - 4-conductor, straight and right-angle "micro" style

**Protection**

- Power Supply: current-limited over-voltage, ESD, reverse polarity
- Outputs: current-limited over-voltage, ESD, over-current

**Environmental**

- Operating Temperature Range:
  - 0° to 60°C @ 12 VDC supply
  - 0° to 50°C @ 24 VDC supply
- Storage Temperature Range: -40° to 100°C (-40° to 212°F)
- Operating Humidity: 100%
- Protection Ratings: NEMA 4X, IP67
- Chemical Resistance: Resists most acids and bases, including most food products

**Agency Approvals**

- CE Mark: CE conformity is declared to:
  - EN61326:1997 (annex A, industrial) including amendment A1:1998. EN55011 Group 1 Class A.
- Declaration of Conformity available upon request

**Construction**

- Dimensions:
  - Barrel
    - Cable Model: 18 mm dia. x 1 mm threaded housing x 65 mm (2.55") long
    - Connector Model: 18 mm dia. x 1 mm threaded housing x 102 mm (4") long, including connector/cable assembly
  - Flat-profile
    - Cable Model: 30 mm (1.182") H x 16.25 mm (0.640") W x 93 mm (3.66") L
    - Connector Model: 30 mm (1.182") H x 16.25 mm (0.640") W x 84.40 mm (3.322") L
- Housing:
  - Shock and vibration resistant
  - Case: ULTEM®\* plastic (FDA Approved) (SS303 stainless steel available only in 18 mm barrel-style)
  - Transducer Face: Silicone rubber - gray
  - Sensor Cables: Lead-free PVC jacket, black (Model AC117)
  - LED: Polycarbonate

**Accessories**

**18 mm Barrel Mounting Hardware and Cables**

- Model AC117**, Right-angle, M12 micro, 4-conductor, connector/cable assembly, 5 m (16') with built-in LEDs for barrel connector-style prox sensors
- Model AC127**, Straight, M12 micro, 4-conductor, connector/cable assembly, 5 m (16') with built-in LEDs for barrel connector-style prox sensors
- Model AC226**, Stainless and polyamide conveyor-rail clamp/bracket set
- Model AC227**, Large, right-angle, stainless mounting bracket
- Model AC228**, Small, right-angle, stainless mounting bracket

**Flat-profile Mounting Hardware and Cables**

- Model AC130**, Straight, M12 micro, 4-conductor, connector/cable assembly, 5 m (16'), for flat-profile, connector-style sensors
- Model AC132**, Right-angle, M12 micro, 4-conductor, connector/cable assembly, 5 m (16'), for flat-profile, connector-style sensors
- Model AC231**, Straight, stainless, mounting bracket
- Model AC232**, S-shaped, stainless, mounting bracket

See page 7-1 for accessory photos.

\* ULTEM® is a registered trademark of The General Electric Co.

# Selection Chart

## SM602 Series Dual Level

Model No.	Power		Near Limit (Near Alarm) Distance from Far Limit (Far Alarm)	Far Limit (Far Alarm)	Transducer Silicone*	Materials			Special Features
	12-24VDC	Connection Style				18mm ULTEM®	18mm Stainless	Flat-profile ULTEM®	
SM602A-404-00	■	■	6.4 mm (1/4")	102 mm (4")	■	■	■	■	Pump-out Latch
SM602A-416-00	■	■	25 mm (1")	102 mm (4")	■	■			Pump-out Latch
SM602A-432-00S	■	■	51 mm (2")	102 mm (4")	■	■			Pump-out Latch
SM602A-404-10	■	■	6.4 mm (1/4")	102 mm (4")	■	■	■		Pump-in Latch
SM602A-416-10	■	■	25 mm (1")	102 mm (4")	■	■			Pump-in Latch
SM602A-432-10	■	■	51 mm (2")	102 mm (4")	■	■			Pump-in Latch
SM602A-504-00	■	■	6.4 mm (1/4")	127 mm (5")	■	■			Pump-out Latch
SM602A-516-00S	■	■	25 mm (1")	127 mm (5")	■		■		Pump-out Latch
SM602A-532-00FP	■	■	51 mm (2")	127 mm (5")	■			■	Pump-out Latch
SM602A-504-10	■	■	6.4 mm (1/4")	127 mm (5")	■	■			Pump-in Latch
SM602A-516-10S	■	■	25 mm (1")	127 mm (5")	■		■		Pump-in Latch
SM602A-532-10FP	■	■	51 mm (2")	127 mm (5")	■			■	Pump-in Latch
SM602A-632-20	■	■	51 mm (2")	152 mm (6")	■	■			Dual-Alarm, Normally Open (N.O.)
SM652A-404-00	■	■	6.4 mm (1/4")	102 mm (4")	■	■			Pump-out Latch
SM652A-416-00	■	■	25 mm (1")	102 mm (4")	■	■			Pump-out Latch
SM652A-432-00	■	■	51 mm (2")	102 mm (4")	■	■			Pump-out Latch
SM652A-404-10	■	■	6.4 mm (1/4")	102 mm (4")	■	■			Pump-in Latch
SM652A-416-10	■	■	25 mm (1")	102 mm (4")	■	■			Pump-in Latch
SM652A-432-10	■	■	51 mm (2")	102 mm (4")	■	■			Pump-in Latch
SM652A-504-00	■	■	6.4 mm (1/4")	127 mm (5")	■		■		Pump-out Latch
SM652A-516-00S	■	■	25 mm (1")	127 mm (5")	■			■	Pump-out Latch
SM652A-532-00FP	■	■	51 mm (2")	127 mm (5")	■	■			Pump-out Latch
SM652A-504-10	■	■	6.4 mm (1/4")	127 mm (5")	■	■			Pump-in Latch
SM652A-516-10S	■	■	25 mm (1")	127 mm (5")	■		■		Pump-in Latch
SM652A-532-00FP	■	■	51 mm (2")	127 mm (5")	■			■	Pump-in Latch
SM652A-632-20	■	■	51 mm (2")	152 mm (6")	■	■			Dual-Alarm, Normally Open (N.O.)

\* = See definition in Sensing Terms  
All possible sensor configurations are not listed here.

SUPERPROX® SM602  
SERIES

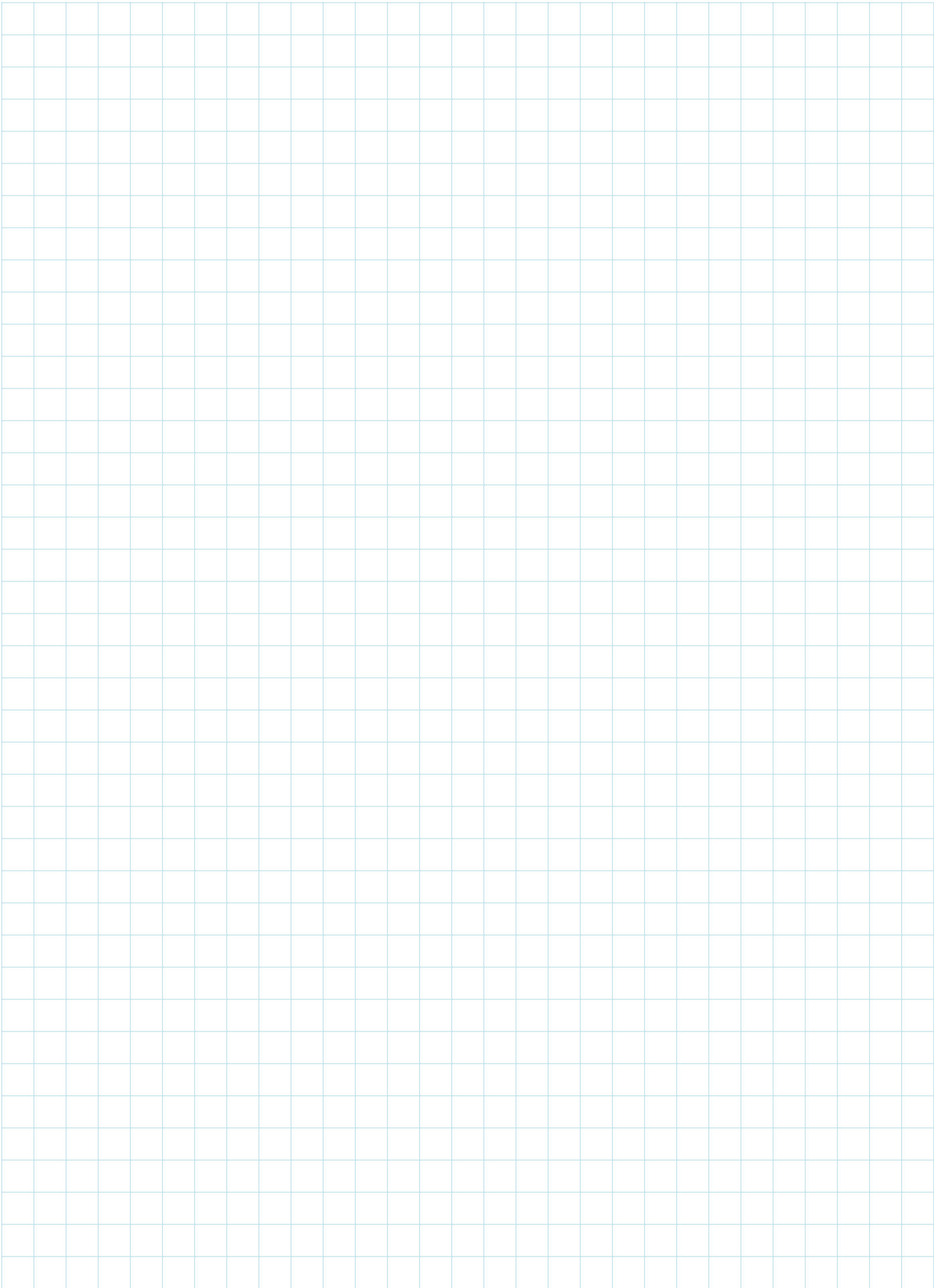

## SUPERPROX® Ultrasonic Analog Output Sensors



CE

DeviceNet™

### One tough little prox with an analog output

It is one of the smallest, fastest, most repeatable, analog sensors in the business. The SUPERPROX® Model SM606 series of analog sensors, incorporating the world's leading ultrasonic technology, offers reliable measurement and control of materials with fixed span limits within sensing ranges up to 254 mm (10"). These sensors continuously monitor the distance to an object and generate either a directly proportional or inversely proportional 0 to 10 volt or 4-20 mA output. The sensors detect objects of all colors and materials as small as 1.59 mm (0.0625") diameter, transparent or opaque, liquid or solid. The narrow 7° sonic beam allows the sensor to accurately detect levels in containers with openings as small as 9.52 mm (0.375").

With a response rate as fast as 1.5 ms on the 102 mm range

model, the high resolution SM606 series sensors are capable of detecting rapidly changing object positions as small as 0.686 mm (0.027") at the rate of 667 samples per second. Typical applications include the checking and controlling of fluid levels, measuring speed and position of an object moving on a slide at rates in excess of 50 feet per second, and controlling a web of paper or fabric. Higher gain models can detect very thin materials like thread and wire.

The 18 mm barrel housing sensor is available in either ULTEM® plastic (standard) or SS303 stainless steel. The flat-profile housing is available in ULTEM® plastic only. The sensors are sealed to withstand dusty, dirty, clean-in-place, 100% humidity, high-pressure, and washdown environments.

For sensing applications requiring connection to a DeviceNet network, the flat-profile models in this series are available with this capability as an optional selection.

- High repeatability  
500 kHz ultrasonic frequency
- Fast response -  
as fast as 1.5 ms  
sampling rate
- Self-contained,  
18 mm barrel  
or flat-profile  
housing styles
- Field programmable  
capability in 18 mm  
and flat-profile  
models
- DeviceNet capability  
available in flat-  
profile models
- CE certified

Operating on 15 to 24 VDC, the 500 kHz barrel housing/cable style sensors are equipped with an amber LED; the barrel housing/connector style sensors have two LEDs: amber and green. The flat-profile sensors, in both cable and connector style, have an amber LED. The amber LED increases in intensity as output voltage increases. The green LED indicates power is

being supplied. With protection ratings of NEMA 4X and IP67, the sensors resist most acids and bases, including most food products. The transducer face is made of silicone rubber.

### Operation

The SUPERPROX® Model SM606 series is a self-contained, pulse-echo device that both transmits and receives sonic energy within its programmed sensing range. These sensors use the latest ultrasonic technology with a discriminating microprocessor that allows the sensor to ignore all surrounding sonic interference and detect only the designated object. When an object is within the fixed analog sensing span, the analog output changes proportionally in relation to the analog sensing span limits. For example, if the object is halfway between the analog span limits, the output is 5 volts.

As shown below, Hyde Park offers both direct and inverse proportional analog output models for continuous sensing applications.

### How does it work?

During setup and operation, these SM606 series sensors continually and accurately measure the elapsed time of every pulse echo reception between each pulse transmission. The transmitted pulse begins a time clock to register the elapsed times for the received pulse echoes. Given the elapsed time, the sensor software calculates the distance traveled out to the object and back to the sensor, using the formula,  $D = TV_s/2$ , where: D = distance from the sensor to the object; T = elapsed time between the pulse transmission and its echo

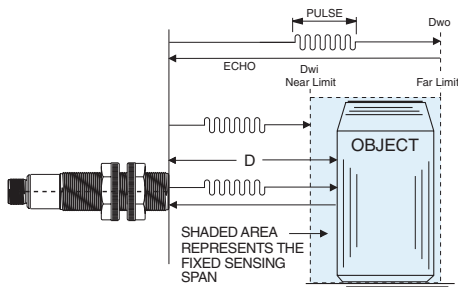

receptions;  $V_s$  = the velocity of sound, approximately 1100 feet per second.

During operation, the calculated distance (D) between the sensor and the object is compared to the distances between the sensor and the fixed span limits. These limits are shown in the illustration at right as  $D_{wi}$  and  $D_{wo}$ . If D is at or within the fixed span limits, an output value for D, relative to the analog sensing span limits, is generated.

## Model Reference Guide - SM606 Series

Use the guide below to ensure the correct model number is specified for the application. Please note that not all sensor model combinations are available.

### EXAMPLE MODEL:

**SM606A-448-00S**

#### Ultrasonic Miniature Proximity Series

#### Power/Connection Type

- 0...15 to 24 VDC / cable style
- 5...15 to 24 VDC / "micro" connector style

#### Sensing Function

- 6...Analog

#### Design Level

- A...Applies to all models

#### Sensing Range (Far Limit)

- 1 to 9...inches, not in fractions
- B...254 mm (10")

#### Sensing Span (Distance from Far Limit to Near Limit)\*\*

- 08...13 mm (1/2")
- 16...25 mm (1")
- 32...51 mm (2")
- 48...77 mm (3")
- 80...127 mm (5")
- 96...152 mm (6")
- OB...203 mm (8")

#### Output Configuration (4-20 mA must be in flat-profile model)

- 00...Inverse 0 to 10 volts
- 01...Direct 0 to 10 volts
- 03...Inverse 0 to 10 volts, loss of echo signal hold
- 06...Direct 0 to 10 volts, loss of echo signal hold
- 10...Inverse 4-20mA
- 11...Direct 4-20 mA
- 13...Inverse 4-20mA, loss of echo signal hold
- 16...Direct 4-20 mA loss of echo signal hold

#### Options

Contact factory for available options

#### Housing Types

- ...No letter indicates standard ULTEM® - 18 mm barrel housing
- FP...ULTEM® flat-profile housing
- S...SS303 stainless steel - 18 mm barrel housing

\* ULTEM® is a registered trademark of The General Electric Company.

\*\* Available only in 102 mm (4") range models.

\*\*Not allowed inside the deadband. Deadband is 0.75" for ranges  $\leq 7'$  and 1.25" for ranges  $> 7'$

Field configurable and DeviceNet Model Reference Guides start on page 4-145.

## Direct Proportional Output

The analog signal value increases as the object moves closer to the near span limit.

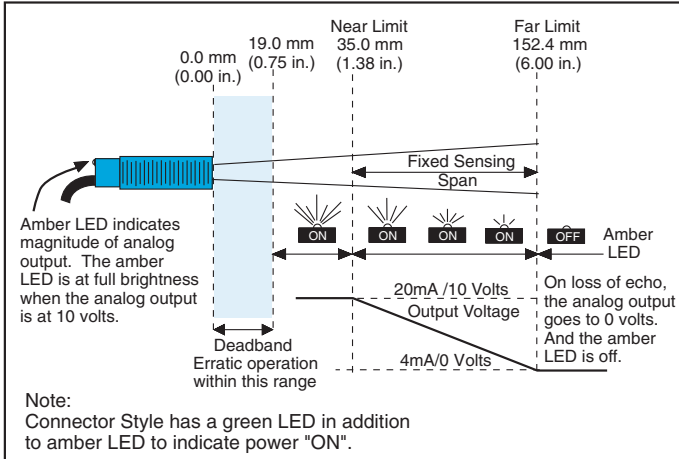

## Inverse Proportional Output

The analog signal value decreases as the object moves closer to the near span limit.

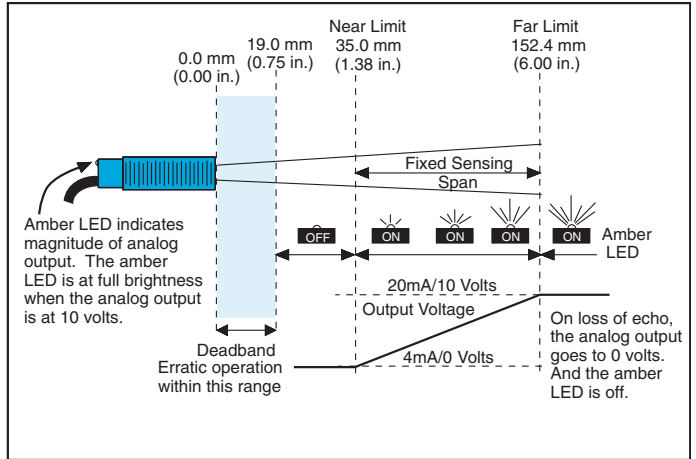

\* Note: The Cable style sensors have an amber signal LED only; no green LED.

## Loss of Echo Signal Hold Output Configuration

The sensor model with this configuration makes it possible, upon loss of echo signals, to hold at the analog signal value of the last echo received. When the sensor again receives echoes within its sensing range, the analog signal is updated to a value indicating the object's position at that moment relative to the span limits.

## Electrical Wiring

The sensor wires must be run in conduit free of any AC power or control wires.

## Cable Style Model Wire Assignments

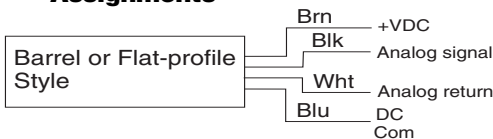

## Connector Style Model Pin Assignments

"Flat-profile" style

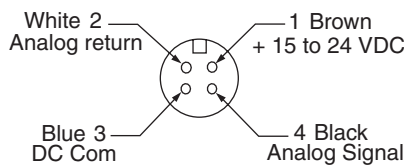

Barrel style

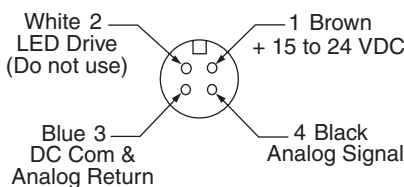

## Dimensions

### Barrel Cable Style

(ULTEM® plastic and stainless steel)

SM606A-444-XX, SM606A-444-XXS, SM606A-674-XX, SM606A-674-XXS

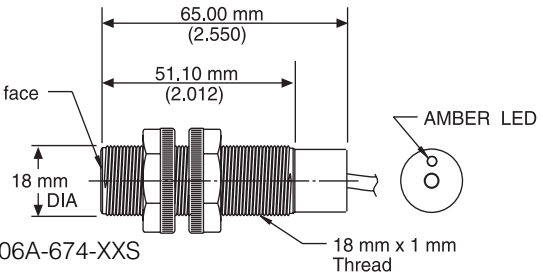

### Barrel Connector Style

(ULTEM® plastic and stainless steel)

SM656A-444-XX, SM656A-444-XXS, SM656A-674-XX, SM656A-674-XXS

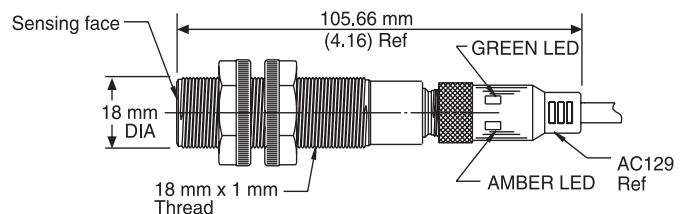
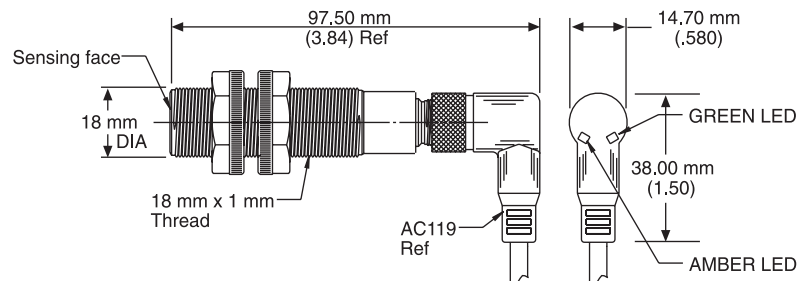
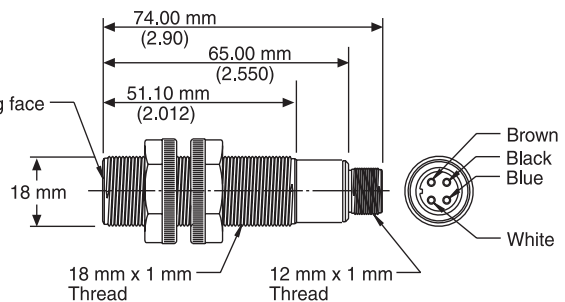

## Dimensions

### “Flat-profile” Connector Style (ULTEM® plastic)

SM656A-444-XXFP, 656A-674-XXFP

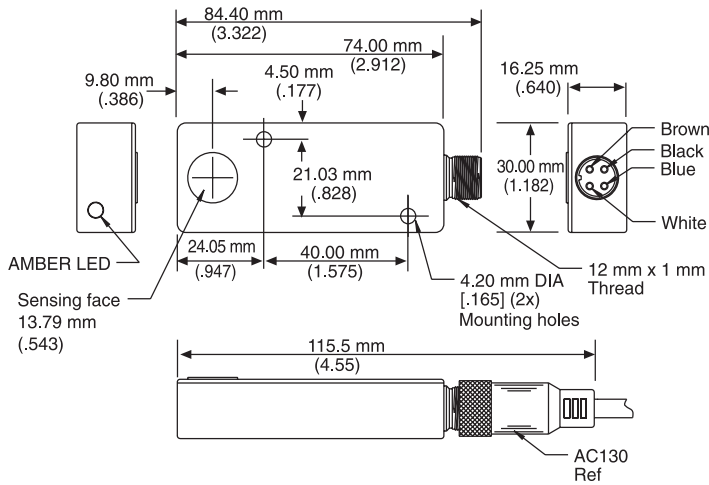

### “Flat-profile” Cable Style (ULTEM® plastic)

SM606A-444-XXFP, 606A-674-XXFP

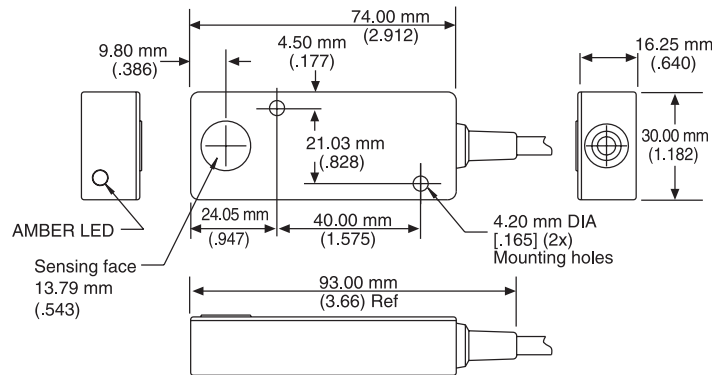

## Mounting Accessories

**AC119** Right-angle, M12 micro, 4-conductor, connector/cable assembly, 5 m (16'), with built-in LEDs (for barrel connector-style sensors)

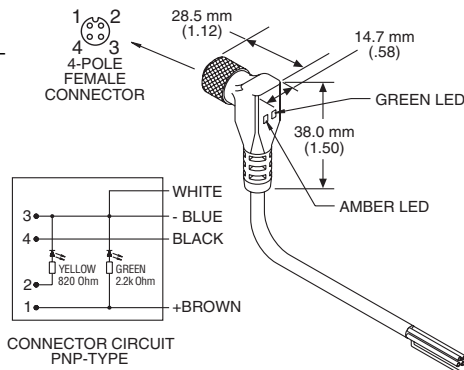

**AC130** Straight, M12 micro, 4-conductor, connector/cable assembly, 5 m (16') (for flat-profile connector-style sensors)

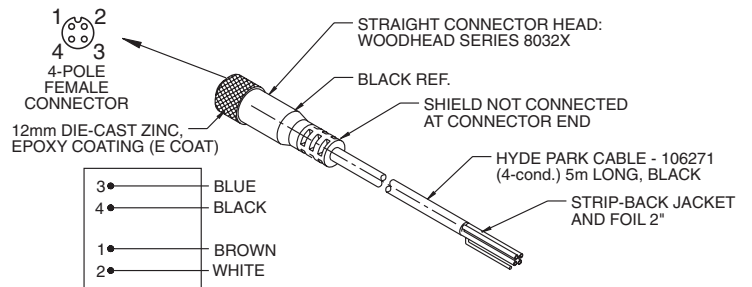

**AC129** Straight, M12 micro, 4-conductor, connector/cable assembly, 5 m (16'), with built-in LEDs (for barrel connector-style sensors)

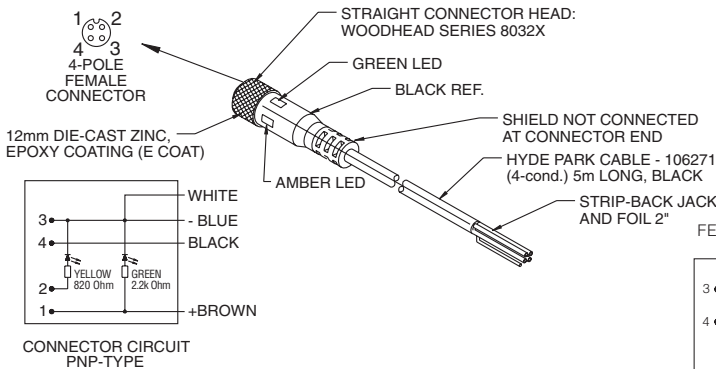

**AC132** Right-angle, M12 micro, 4-conductor, connector/cable assembly, 5 m (16') (for flat-profile connector-style sensors)

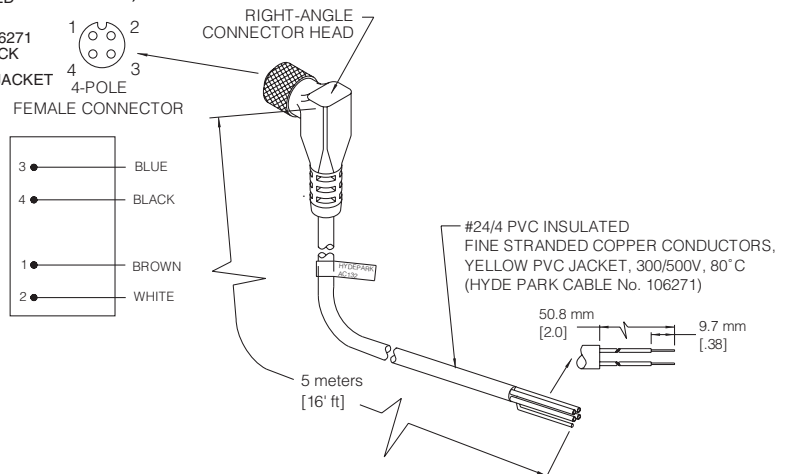



**AC226** Stainless and polyamide conveyor-rail clamp/bracket set (for 18 mm barrel sensors)

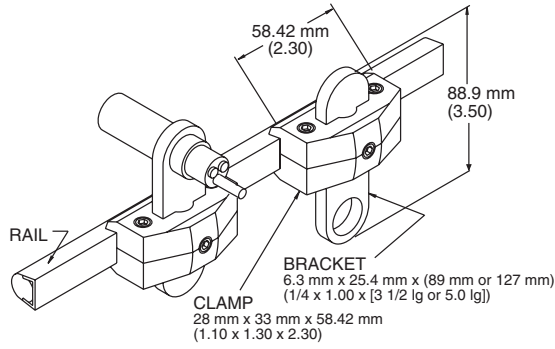

**AC227** Large, right-angle, stainless, mounting bracket (for 18 mm barrel sensors)

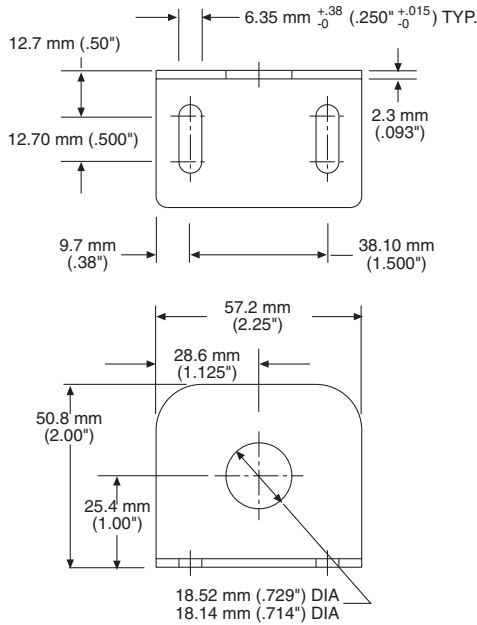

**AC228** Small, right-angle, stainless, mounting bracket (for 18 mm barrel sensors)

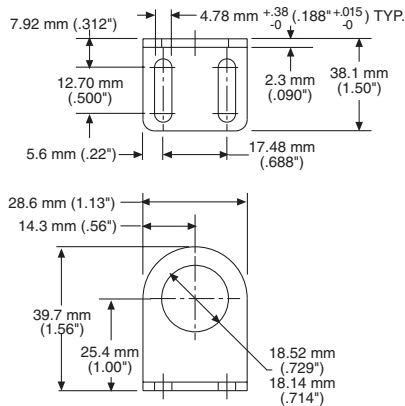

**AC231** Straight, stainless mounting bracket (for flat-profile sensors)

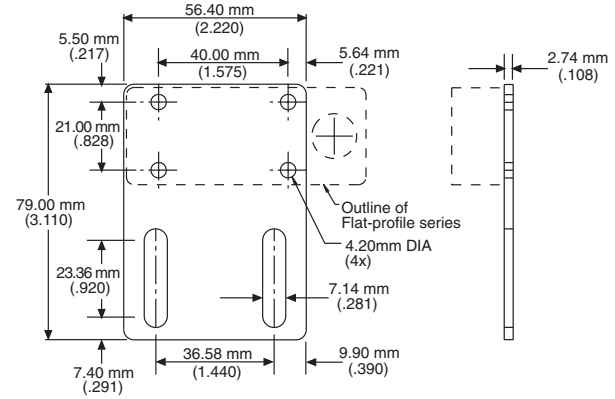

**AC232** S-shaped, stainless mounting bracket (for flat-profile sensors)

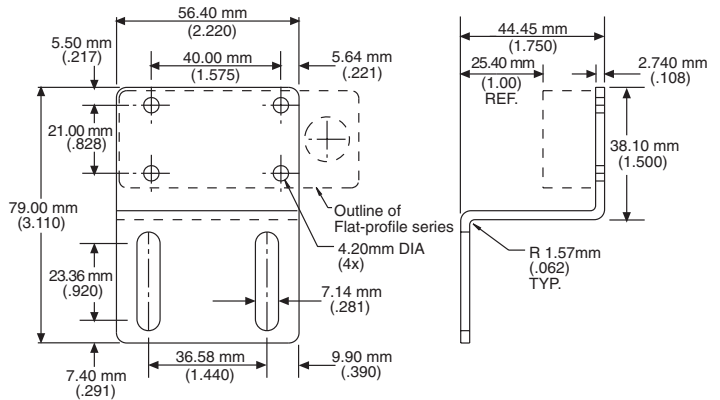

## General Specifications

### Sensing

#### Ranges:

Up to 254 mm (10")

#### Spans:

From 3.18 mm (1") to 228.6 mm (9")

#### Detection Benchmarks:

Models with Ranges to 177.8 mm (7"):

1.59 mm (1/16") diameter rod at a distance of 63.5 mm (2.5")

Max.  $\pm 10^\circ$  tilt of large flat object at a distance of 127 mm (5")

Models with Ranges from over 177.8 mm (7")

to 254 mm (10"):

1.59 mm (1/16") diameter rod at a distance of 76.2 mm (3")

Max.  $\pm 10^\circ$  tilt of large flat object at a distance of 203.2 mm (8")

#### Position Sensing @ 20°C

##### Resolution, Position:

Voltage Model span/1023

Current Model span/818

but never less than 0.043 mm (0.0017") for either type

##### Resolution, Output:

Voltage Model 9.775mV

Current Model 15.6uA

##### Window Edge Position (either edge):

Error, maximum  $\pm 1.57$  mm (0.062")

Repeatability, max. error  $\pm 0.381$  mm (0.015")

##### Zero Offset:

Voltage Model  $+18$ mV/-11mV

Current Model 4mA +0.11mA/-0.141mA

##### Full Scale Offset, maximum:

Voltage Model  $\pm 43$ mV

Current Model  $+0.147$ mA/-0.300mA

##### Slope Error, maximum:

0.59% of Span (1% to 99% of Span)

##### Non-linearity, maximum:

0.76 mm (.030")

##### Temperature Compensation: -20° to 60°C

##### Position Error Due to Temperature Shift:

$\pm 0.159$  mm (0.062")

##### Sonic Frequency: 500 kHz

##### Sonic Cone Angle: 7° (see beam plot, page 4-72)

##### Sensing Bandwidth (sinusoidal oscillation):

50 Hz

### Power Requirements

#### Supply Voltage:

15 VDC to 24 VDC  $\pm 10\%$ , regulated supply

#### Current Consumption:

50 mA max. (excluding load)

#### Power Consumption:

1.2 W max. (excluding load)

### Output

#### Voltage Model

Range: 0-10 VDC

Min. Load Resistance: 1000 Ohms

#### Current Model (flat-profile only)

Range: 4-20 mA (0-20 mA optional)

Load Resistance: 0.1 to 350 Ohms

### Response Time

2.5 ms (Standard)

1.5 ms (Optional)

### Indicators

Green LED (connector model only): power

Amber LED (connector & cable models): intensity increases as output voltage increases

### Connections

#### Cable Style Models:

24 AWG, foil shield, lead-free, PVC jacketed,

4-conductor, 3 meters (10') long

#### Connector Style Models:

4-pin, 12 mm "micro" style

LEDs not built into this sensor. Must use AC119 right-angle mating connector with built-in LEDs.

No other mating connector cable may be substituted due to unique LED circuit impedance.

### Protection

Power Supply: current-limited over-voltage, ESD, reverse polarity

Outputs: current-limited over-voltage, ESD, over-current

### Environmental

#### Operating Temperature Range:

0° to 60°C @ 15 VDC supply

0° to 50°C @ 24 VDC supply

Storage Temperature Range: -40° to 100°C (-40° to 212°F)

Operating Humidity: 100%

Protection Ratings: NEMA 4X, IP67

Chemical Resistance: Resists most acids and bases, including most food products.

### Agency Approvals

CE Mark: CE conformity is declared to:

EN61326:1997 (annex A, industrial) including amendment A1:1998. EN55011 Group1 Class A.

*Declaration of Conformity available upon request*

### Construction

#### Dimensions:

Barrel

Cable Model: 18 mm dia. x 1 mm threaded housing x 65 mm (2.55") long

Connector Model: 18 mm dia. x 1 mm threaded housing x 102 mm (4") long, including connector/cable assembly

#### Flat-profile

Cable Model: 30 mm (1.182") H

x 16.25 mm (0.640") H

x 93 mm (3.66") L

Connector Model: 30 mm (1.182") H

x 16.25 mm (0.640") W

x 84.40 mm (3.322") L

#### Housing:

Shock and vibration resistant

Case: ULTEM®\* plastic (FDA Approved)

(SS303 stainless steel available only in 18 mm barrel-style)

Transducer Face: Silicone rubber - gray

Sensor Cables: Nontoxic PVC jacket, food grade

LED: Polycarbonate

\* ULTEM® is a registered trademark of The General Electric Co.

## Accessories

### 18 mm Barrel Mounting Hardware and Cables

**Model AC119**, Right-angle, M12 micro, 4-conductor, connector/cable assembly, 5 m (16'), with built-in LEDs for connector-style prox sensors

**Model AC129**, Straight, M12 micro, 4-conductor, connector/cable assembly, 5 m (16'), with built-in LEDs for connector-style prox sensors

**Model AC226**, Stainless and polyamide conveyor-rail clamp/bracket set

**Model AC227**, Large, right-angle, stainless, mounting bracket

**Model AC228**, Small, right-angle, stainless, mounting bracket

### Flat-profile Mounting Hardware and Cables

**Model AC130**, Straight, M12 micro, 4-conductor, connector/cable assembly, 5 m (16'), for flat-profile, connector-style prox sensors

**Model AC132**, Right angle, M12 micro, 4-conductor, connector/cable assembly, 5 m (16'), for flat-profile, connector-style sensors

**Model AC231**, Straight, stainless, mounting bracket

**Model AC232**, S-shaped, stainless, mounting bracket

See page 7-1 for accessory photos.

# Selection Chart

## SM606 Series Analog Output

Model No.	15/24 VDC Power Version		Range	Span	Output Configuration					Materials			Notes	
	Cable	Connector			Style	Inv.0-10V, 2.5ms cycle	Dir.0-10V, 2.5ms cycle	Inv.0-10V, 1.5ms cycle	Inv.0-10V, 2.5ms cycle	Dir.0-10V, 1.5ms cycle	Transducer	Housing		
										Silicone*	18mm ULTEM*	18mm Stainless	Flat-profile	
SM606A-444-00•	■	■	102mm (4")	70mm (2.75")	■					■	■			
SM606A-444-00FP•	■	■	102mm (4")	70mm (2.75")	■					■			■	
SM606A-444-00S•	■	■	102mm (4")	70mm (2.75")	■					■	■			
SM606A-444-01	■	■	102mm (4")	70mm (2.75")		■				■		■		
SM606A-444-01FP	■	■	102mm (4")	70mm (2.75")		■				■		■		
SM606A-444-01S	■	■	102mm (4")	70mm (2.75")		■				■		■		
SM606A-444-02	■	■	102mm (4")	70mm (2.75")			■			■	■			
SM606A-444-02FP	■	■	102mm (4")	70mm (2.75")			■			■		■		
SM606A-444-02S	■	■	102mm (4")	70mm (2.75")			■			■		■		
SM606A-444-03	■	■	102mm (4")	70mm (2.75")				■		■	■			Loss of echo signal hold
SM606A-444-03FP	■	■	102mm (4")	70mm (2.75")				■		■		■		Loss of echo signal hold
SM606A-444-03S	■	■	102mm (4")	70mm (2.75")				■		■	■			Loss of echo signal hold
SM606A-444-04	■	■	102mm (4")	70mm (2.75")					■	■	■			
SM606A-444-04FP	■	■	102mm (4")	70mm (2.75")					■	■		■		
SM606A-444-04S	■	■	102mm (4")	70mm (2.75")					■	■		■		
SM606A-674-00•	■	■	152mm (6")	117mm (4.62")	■					■	■			
SM606A-674-00FP•	■	■	152mm (6")	117mm (4.62")	■					■			■	
SM606A-674-00S•	■	■	152mm (6")	117mm (4.62")	■					■	■			
SM606A-674-01	■	■	152mm (6")	117mm (4.62")		■				■		■		
SM606A-674-01FP	■	■	152mm (6")	117mm (4.62")		■				■		■		
SM606A-674-01S	■	■	152mm (6")	117mm (4.62")		■				■		■		
SM606A-674-02	■	■	152mm (6")	117mm (4.62")			■			■	■			
SM606A-674-02FP	■	■	152mm (6")	117mm (4.62")			■			■		■		
SM606A-674-02S	■	■	152mm (6")	117mm (4.62")			■			■		■		
SM606A-674-03	■	■	152mm (6")	117mm (4.62")				■		■	■			Loss of echo signal hold
SM606A-674-03FP	■	■	152mm (6")	117mm (4.62")				■		■		■		Loss of echo signal hold
SM606A-674-03S	■	■	152mm (6")	117mm (4.62")				■		■	■			Loss of echo signal hold
SM606A-674-04	■	■	152mm (6")	117mm (4.62")					■	■	■			
SM606A-674-04FP	■	■	152mm (6")	117mm (4.62")					■	■		■		
SM606A-674-04S	■	■	152mm (6")	117mm (4.62")					■	■		■		
SM656A-444-00•	■	■	102mm (4")	70mm (2.75")	■					■	■			
SM656A-444-00FP•	■	■	102mm (4")	70mm (2.75")	■					■			■	
SM656A-444-00S•	■	■	102mm (4")	70mm (2.75")	■					■	■			
SM656A-444-01	■	■	102mm (4")	70mm (2.75")		■				■		■		
SM656A-444-01FP	■	■	102mm (4")	70mm (2.75")		■				■		■		
SM656A-444-01S	■	■	102mm (4")	70mm (2.75")		■				■		■		
SM656A-444-02	■	■	102mm (4")	70mm (2.75")			■			■	■			
SM656A-444-02FP	■	■	102mm (4")	70mm (2.75")			■			■		■		
SM656A-444-02S	■	■	102mm (4")	70mm (2.75")			■			■		■		
SM656A-444-03	■	■	102mm (4")	70mm (2.75")				■		■	■			Loss of echo signal hold
SM656A-444-03FP	■	■	102mm (4")	70mm (2.75")				■		■		■		Loss of echo signal hold
SM656A-444-03S	■	■	102mm (4")	70mm (2.75")				■		■	■			Loss of echo signal hold
SM656A-444-04	■	■	102mm (4")	70mm (2.75")					■	■	■			
SM656A-444-04FP	■	■	102mm (4")	70mm (2.75")					■	■		■		
SM656A-444-04S	■	■	102mm (4")	70mm (2.75")					■	■		■		
SM656A-674-00•	■	■	152mm (6")	117mm (4.62")	■					■	■			
SM656A-674-00FP•	■	■	152mm (6")	117mm (4.62")	■					■			■	
SM656A-674-00S•	■	■	152mm (6")	117mm (4.62")	■					■	■			
SM656A-674-01	■	■	152mm (6")	117mm (4.62")		■				■		■		
SM656A-674-01FP	■	■	152mm (6")	117mm (4.62")		■				■		■		
SM656A-674-01S	■	■	152mm (6")	117mm (4.62")		■				■		■		
SM656A-674-02	■	■	152mm (6")	117mm (4.62")			■			■	■			
SM656A-674-02FP	■	■	152mm (6")	117mm (4.62")			■			■		■		
SM656A-674-02S	■	■	152mm (6")	117mm (4.62")			■			■		■		
SM656A-674-03	■	■	152mm (6")	117mm (4.62")				■		■	■			Loss of echo signal hold
SM656A-674-03FP	■	■	152mm (6")	117mm (4.62")				■		■		■		Loss of echo signal hold
SM656A-674-03S	■	■	152mm (6")	117mm (4.62")				■		■	■			Loss of echo signal hold
SM656A-674-04	■	■	152mm (6")	117mm (4.62")					■	■	■			
SM656A-674-04FP	■	■	152mm (6")	117mm (4.62")					■	■		■		
SM656A-674-04S	■	■	152mm (6")	117mm (4.62")					■	■		■		

• = Most commonly stocked sensors \* = See definition in Sensing Terms.  
All possible sensor configurations are not listed here.

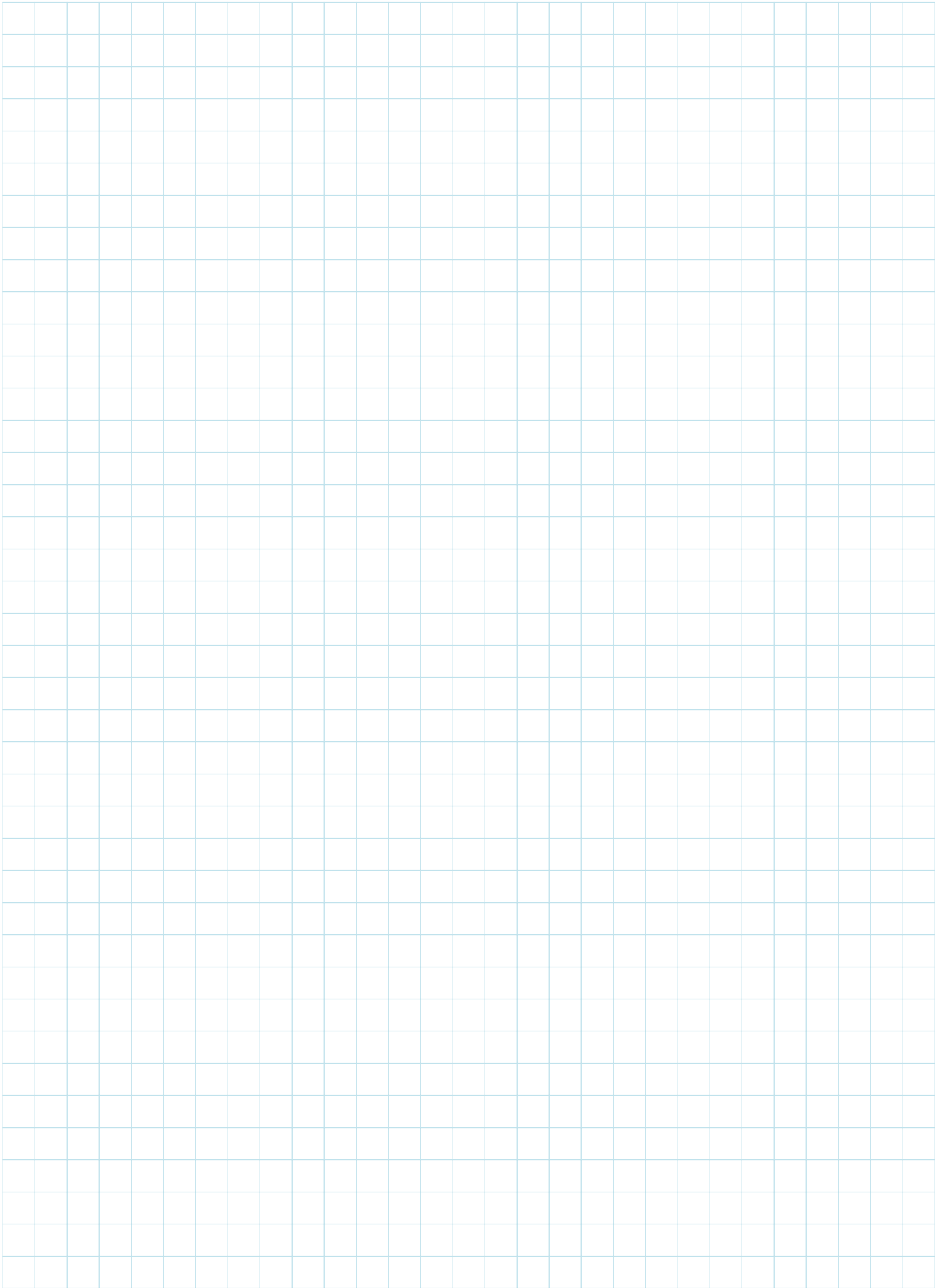



**This fast, high-gain, ultrasonic proximity sensor detects objects as small as 0.076 mm (0.003") in width at a speed of 400 inches per second.**

Where very small target sensing applications require fast, repeatable, reliable, and precise on/off control, the high-frequency, fixed-window SUPERPROX® Model SM607 series ultrasonic proximity sensors are the ideal solution. Combining new and unique piezoelectric transducer and microprocessor technology, this "tough little prox" from Hyde Park combines high speed and high sensitivity in the reliable detection of very small objects and edges. This sensor series has fixed sensing windows as small as 3 mm (0.125") within sensing ranges up to 63.5 mm (2.5"). The sensor's advanced ultrasonic technology, the world's finest, allows for a deadband as short as 38.1 mm (1.5"), resulting in a quicker decay of "cross talk" and the capability of closer object detection. Another benefit

of the technology is revealed in a sampling rate of 0.5 ms, 2000 samples per second and the detection of small reflective surfaces moving past the sensor at 400 inches per second.

For sensing applications requiring connection to a DeviceNet network, the flat-profile models in this series are available with this capability as an optional selection.

By virtue of its very high gain and speed, the SM607 noncontact sensor offers reliable detection of objects as small as 0.076 mm (0.003") diameter regardless of material, color, or shape. These include such items as: thin wires, threads, floss, filaments, electrical connections, fine glue beads on box tops, bag seams, and clear optical extrusions. The high gain and speed work together to create a new edge detection system that can be used on high-speed container lines in detecting tamper-proof safety seals, labels, and caps. Other applications include detecting paper and film edges, tape on packages, web edges, bag seams, and wherever there's a need to upgrade a metal prox function. The sensors detect all

## SUPERPROX® Ultrasonic Proximity Sensors

### Small Target Sensing

- *Fast response - 0.5 ms sampling rate*
- *Fixed sensing window*
- *Self-contained, 18 mm barrel or flat-profile housing styles*
- *Ideal for the precise detection of thin edges, as in labels and tamper-proof seals*
- *Field programmable capability in 18 mm and flat-profile models*
- *DeviceNet Capability available in flat-profile models*
- *CE certified*

materials, transparent or opaque, liquid or solid.

With protection ratings of NEMA 4X and IP67, these sensors are impervious to changing light conditions, colors, noise, dust, 100% humidity, caustic chemicals, and other hostile environments. They are resistant to most acids and bases, including most food products. The sensing transducer is made of silicone rubber and the sensors are CE certified. Easy to install, the sensors are

available in three different housing styles. The 18 mm barrel housing sensors are available in either ULTEM® plastic (standard) or SS303 stainless steel. The “flat-profile” housing sensors are available only in ULTEM® plastic. As with all SUPERPROX® sensors, cable and connector styles are available.

Operating on 12 to 24 VDC, the 500 kHz sensors are equipped with sinking type (NPN) and sourcing type (PNP) outputs, a green LED to indicate power “on” and an amber LED to indicate when the object is detected within the fixed window.

The SUPERPROX® Model SM607 barrel- and flat-profile-style proximity sensors are today’s answer for very small object detection and improved productivity throughout the plant.

### Operation

The SUPERPROX® Model SM607 series is a self-contained, pulse-echo device that both transmits and receives sonic energy over a sensing range of up to 51 mm (2”). These sensors use the latest ultrasonic technology with a discriminating microprocessor that allows the sensor to ignore all surrounding sonic interference and detect only the designated object. An object is detected when it is at or within the fixed sensing window.

### How does it work?

During setup and operation, these SM607 series sensors continually and accurately measure the elapsed time of every pulse echo reception between each pulse transmission. The transmitted pulse begins a time clock to register the elapsed times for the received pulse echoes. Given the elapsed time, the sensor software calculates the distance traveled out to the object and back to the sensor, using the formula,  $D = TVs/2$ , where: D = distance from the sensor to the object; T = elapsed time between the pulse transmission and its echo

## Model Reference Guide - SM607 Series

Use the guide below to ensure the correct model number is specified for the application. Please note that not all sensor model combinations are available.

**EXAMPLE MODEL:** **SM6 0 7 A - 2 08 - 00 S**

**Ultrasonic Miniature Proximity Series** ————

**Power/Connection Type** ————

0...12 to 24 VDC / cable style  
5...12 to 24 VDC / “micro” connector style

**Sensing Function** ————

7...Proximity Style - no on/off delay

**Design Level** ————

**Sensing Range** ————

2...51 mm (2")  
A...38.1 mm (1.5") – label edge only

**Sensing Window** ————

02...3 mm (0.125")  
04...6 mm (0.25")  
08...13 mm (0.5")

**Functionality** ————

00...Small object/N.O. outputs  
01...Label edge/N.O. outputs  
10...Small object/N.C. outputs  
11...Label edge/N.C. outputs  
01...Straight label edge/N.O. outputs  
02...Circular label edge/N.O. outputs  
11...Straight label edge/N.C. outputs  
12...Circular label edge/N.C. outputs

**Options** ————

Contact factory for available options

**Housing Types** ————

...No letter indicates standard ULTEM® plastic - 18 mm barrel housing  
FP...ULTEM® flat-profile housing  
S...SS303 stainless steel - 18 mm barrel housing

NOTE: Contact the factory for DeviceNet communications capability in the flat-profile models

\*ULTEM® is a registered trademark of The General Electric Company.

receptions, Vs = the velocity of sound, approximately 1100 feet per second.

During operation, the calculated distance (D) between the sensor and the object is compared to the distances between the sensor and the fixed window limits. These limits are shown in the illustration as Dwi and Dwo. If D is at or within the fixed window limits,

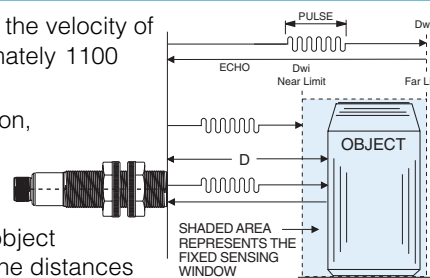

an output change takes place and remains unchanged until the echo either does not return or it returns from outside the fixed window limits.

As shown below, Hyde Park offers normally open (N.O.) or normally closed (N.C.) (sinking and sourcing) output models available for discrete on/off sensing applications.

### Normally Open Output

The sensor output is “On” with the object in the fixed sensing window.

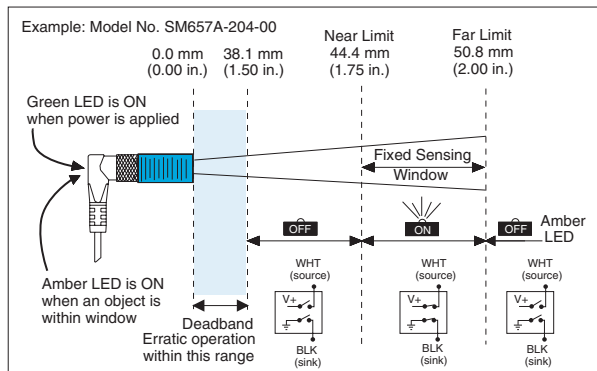

### Normally Closed Output

The sensor output is “Off” with the object in the fixed sensing window.

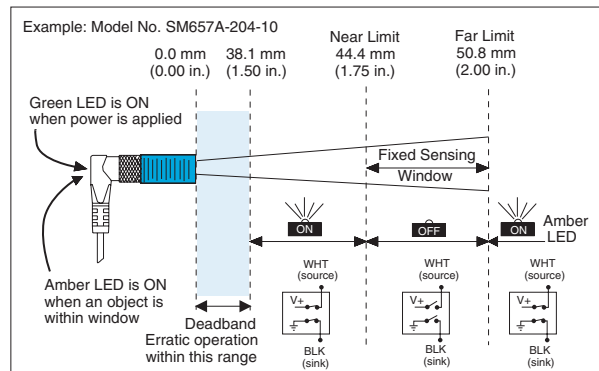

## Mounting

The Model SM607 series sensors should be mounted in brackets that allow them to be adjusted for proper alignment. Hyde Park offers the Model AC226 stainless and polyamide conveyor-rail clamp/bracket set, Model AC227 large, right-angle, stainless mounting bracket, Model AC228 small, right-angle, stainless, mounting bracket, Model AC231 straight, stainless, mounting bracket and Model AC232 s-shaped, stainless, mounting bracket which are illustrated, with dimensions, on Pages 4-104 and 4-105.

## Electrical Wiring

Regardless of model style, the wiring and conductor colors for the Model SM607 series sensors are the same.

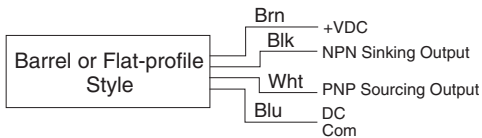

## Outputs

### NPN Sinking and PNP Sourcing

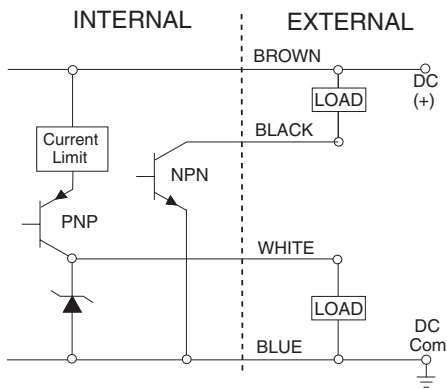

### Connector Style Model Pin Assignments

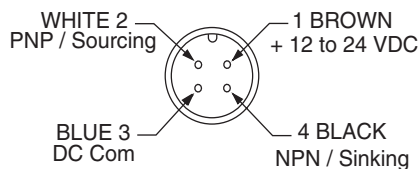

## Dimensions

### Barrel Cable Style

(ULTEM® plastic and stainless steel)  
SM607A-XXX-XX,  
SM607A-XXX-XXS

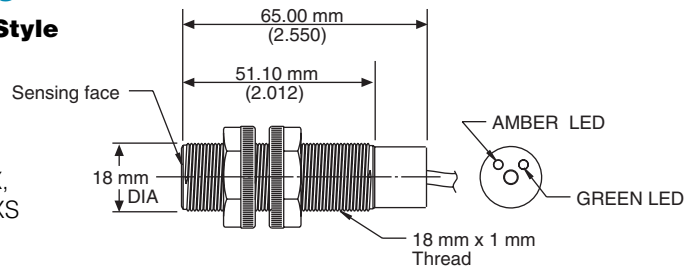

### Barrel Connector Style

(ULTEM® plastic and stainless steel)  
SM657A-XXX-XX,  
SM657A-XXX-XXS

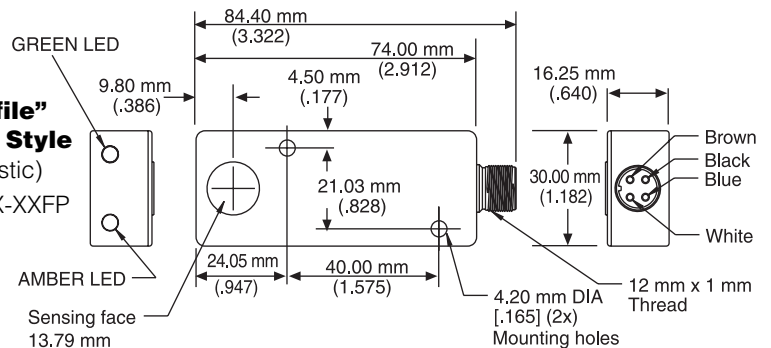
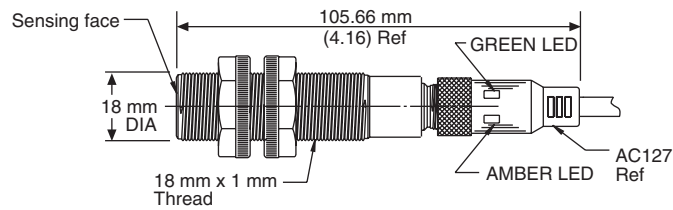
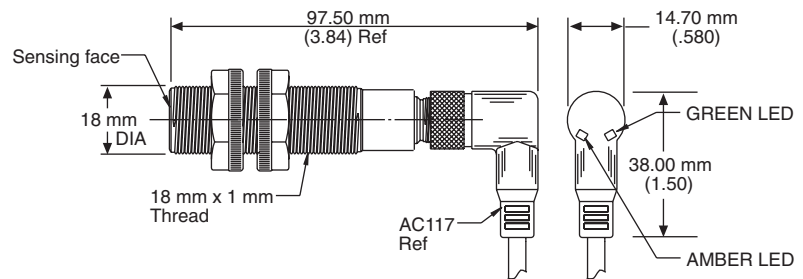
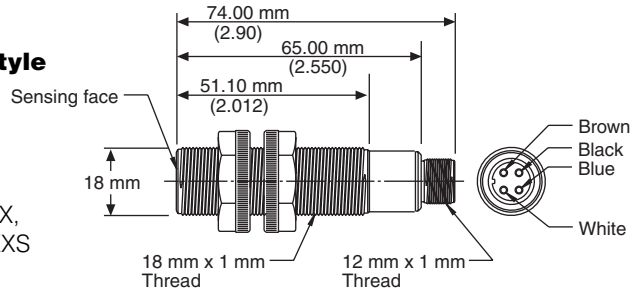

### "Flat-profile" Connector Style

(ULTEM® plastic)  
SM657A-XXX-XXFP

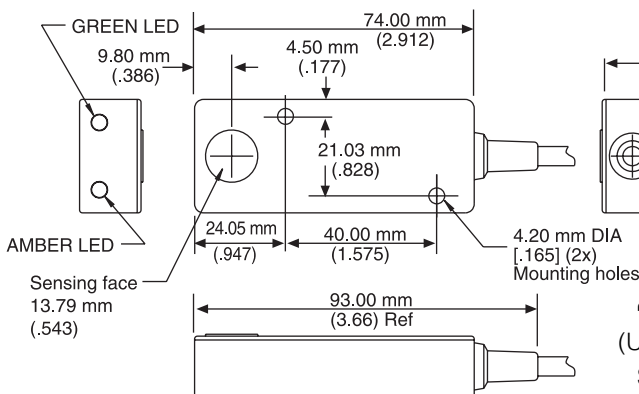

### "Flat-profile" Cable Style

(ULTEM® plastic)  
SM607A-XXX-XXFP

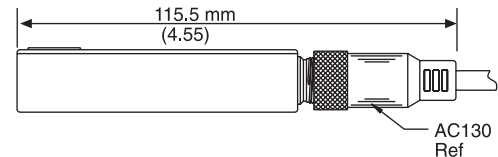

## Mounting Accessories

**AC117** Right-angle, M12 micro, 4-conductor, connector/cable assembly, 5 m (16'), with built-in LEDs (for barrel connector-style sensors)

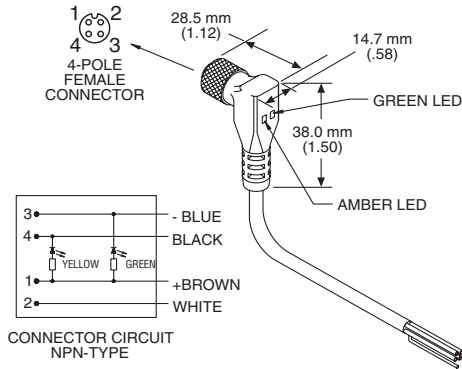

**AC127** Straight, M12 micro, 4-conductor, connector/cable assembly, 5 m (16'), with built-in LEDs (for barrel connector-style sensors)

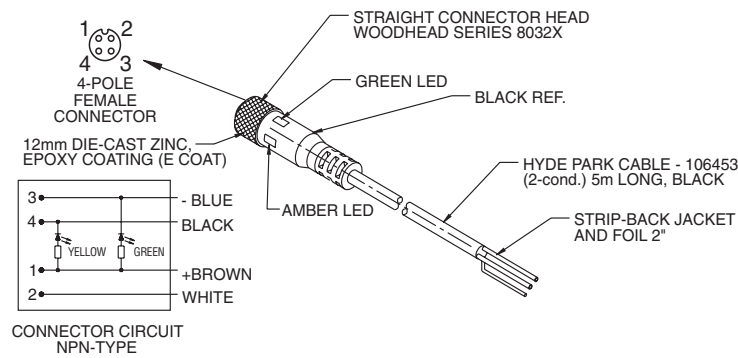

**AC130** Straight, M12 micro, 4-conductor, connector/cable assembly, 5 m (16') (for flat-profile connector-style sensors)

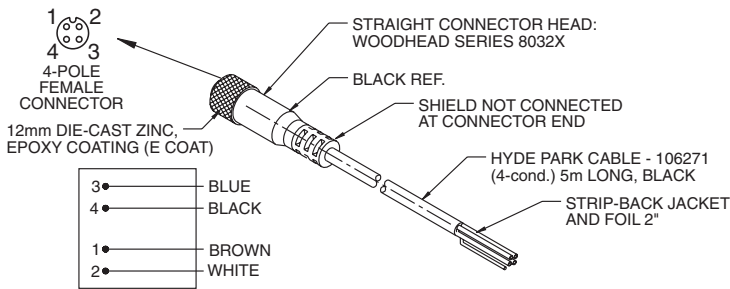

**AC226** Stainless and polyamide conveyor-rail clamp/bracket set (for 18 mm barrel sensors)

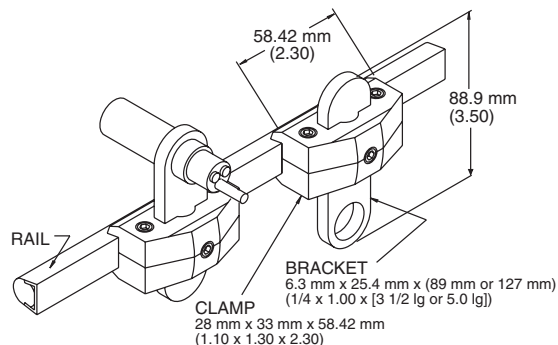

**AC227** Large, right-angle, stainless, mounting bracket (for 18 mm barrel sensors)

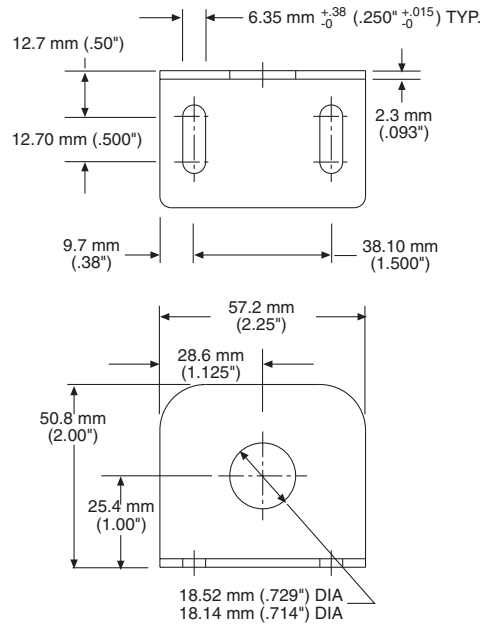

**AC228** Small, right-angle, stainless, mounting bracket (for 18 mm barrel sensors)

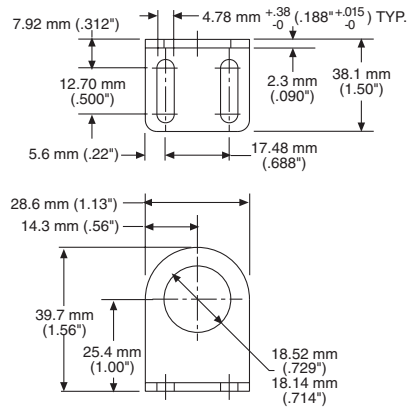

**AC231** Straight, stainless mounting bracket (for flat-profile sensors)

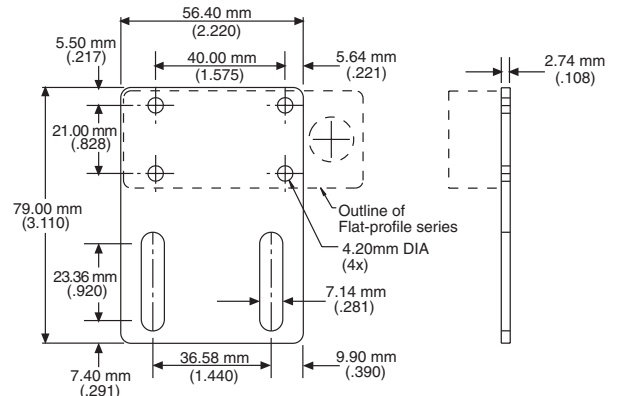



**AC232** S-shaped, stainless mounting bracket (for flat-profile sensors)

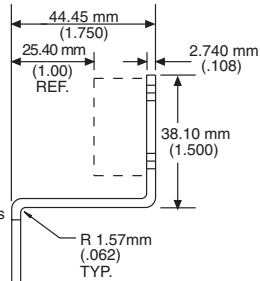
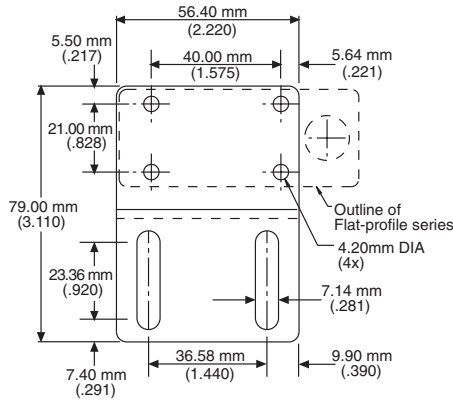

**AC241** Steel/black oxide, 45° angle, label edge mounting bracket used with SUPERPROX SM6X7A-A08-01FP or SM6X7A-A08-11FP flat-profile label sensors

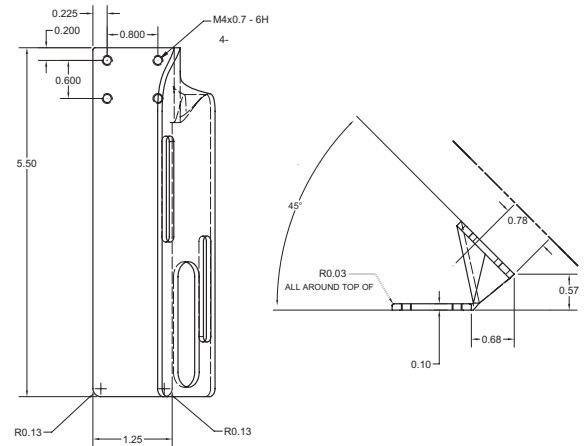

## General Specifications

### Sensing

- Ranges:
  - Up to 51 mm (2")
- Spans:
  - From 3.18 mm (1/8") to 38.1 mm (1.5")
- Window Position, Initial Accuracy:
  - ± 1.59 mm (0.062")
- Window Position Repeatability:
  - ± 0.69 mm (0.027")
- Detection Benchmarks:
  - 0.076 mm (0.003") width at a distance of 51 mm (2")
- Sonic Frequency: 500kHz
- Sonic Cone Angle: 7° (see beam plots, page 4-72)

### Power Requirements

- Supply Voltage:
  - 12 to 24 VDC ± 10%, regulated supply
- Current Consumption:
  - 70 mA max. (excluding load)
- Power Consumption:
  - 1.7 W max. (excluding load)

### Output

- NPN Sinking: 0 to 30 V, 100 mA max.
  - The sinking output is "off" when the sensor is not detecting an object (N.O.)
- PNP Sourcing: 0 to 30 V, 1 A max.
  - The sourcing output is "off" when the sensor is not detecting an object (N.O.)

### Response Time

- "On" 0.5 ms, "Off" 0.5 ms

### Indicators

- Green LED: power "on"
- Amber LED: "on" if object is detected within the window, regardless of output polarity (N.O./N.C.) style. Connector model using cable with built-in LEDs: "on" if NPN output is low.

### Connections

- Cable Style Models:
  - 24 AWG, foil shield, lead-free, PVC jacket, 4-conductor, 3 meters (10') long
- Connector Style Models:
  - 24 AWG, foil shield, lead-free, PVC jacket 4-conductor, right angle "micro" style

### Protection

- Power Supply: current-limited over-voltage, ESD, reverse polarity
- Outputs: current-limited over-voltage, ESD, over-current.

### Environmental

- Operating Temperature Range:
  - 0° to 60°C @ 12 VDC supply
  - 0° to 50°C @ 24 VDC supply
- Storage Temperature Range: -40° to 100°C (-40° to 212°F)
- Operating Humidity: 100%
- Protection Ratings: NEMA 4X, IP67
- Chemical Resistance: Resists most acids and bases, including most food products.

### Agency Approvals

- CE Mark: CE conformity is declared to: EN61326:1997 (annex A, industrial) including amendment A1:1998. EN55011 Group1 Class A. Declaration of Conformity available upon request

### Construction

- Dimensions:
  - Barrel
    - Cable Model: 18 mm dia. x 1 mm threaded housing x 65 mm (2.55") long
    - Connector Model: 18 mm dia. x 1 mm threaded housing x 102 mm (4") long
  - Flat-profile
    - Cable Model: 30 mm (1.182") H x 16.25 mm (0.640") W x 93 mm (3.66") L
    - Connector Model: 30 mm (1.182") H x 16.25 mm (0.640") W x 84.4 mm (3.322") L
- Housing:
  - Shock and vibration resistant
  - Case: ULTEM®\* plastic - (FDA Approved) (SS303 stainless steel available only in 18 mm barrel-style)
  - Transducer Face: Silicone rubber - gray
  - Sensor Cable: Lead-free PVC jacket, black (Model AC117)
  - LED: Polycarbonate

\* ULTEM® is a registered trademark of The General Electric Co.

## Accessories

### 18 mm Barrel Mounting Hardware and Cables

- Model AC117**, Right-angle, M12 micro, 4-conductor connector/cable assembly, 5 m (16') with built-in LEDs for barrel connector-style prox sensors
- Model AC127**, Straight, M12 micro, 4-conductor, connector/cable assembly, 5 m (16'), with built-in LEDs for barrel connector-style prox sensors
- Model AC226**, Stainless and polyamide conveyor-rail clamp/bracket set
- Model AC227**, Large, right-angle, stainless, mounting bracket
- Model AC228**, Small, right-angle, stainless, mounting bracket

### Flat-profile Mounting Hardware and Cables

- Model AC130**, Straight, M12 micro, 4-conductor, connector/cable assembly, 5 m (16'), for flat-profile, connector-style prox sensors
- Model AC231**, Straight, stainless, mounting bracket
- Model AC232**, S-shaped, stainless, mounting bracket AC241 Steel/black oxide, 45° angle, label edge mounting bracket used with SUPERPROX SM6X7A-A08-01FP or SM6X7A-A08-11FP flat-profile label sensors
- Model AC241**, Steel/black oxide, 45° angle, label edge mounting bracket used with the SUPERPROX® SM6X7A-A08-01FP or SM6X7A-A08-11FP flat-profile label sensors

See page 7-1 for accessory photos.

SUPERPROX® SM607 SERIES

# Selection Chart

## SM607 Series Proximity

Model No.	Power Version		Sensing	Range				Window				Transducer			
	12-24 VDC	Connection Style		Range	Near Limit	Far Limit	Fixed Sensing Window	Silicone*	18mm ULTEM® Materials	18mm stainless	Flat-profile	Silicone*	18mm ULTEM® Materials	18mm stainless	Flat-profile
SM607A-A08-01•	■	■		38.1mm (1.5")			12.7mm (.5")	■	■			■			
SM607A-A08-01FP•	■	■		38.1mm (1.5")			12.7mm (.5")	■			■				
SM607A-A08-01S•	■	■		38.1mm (1.5")			12.7mm (.5")	■		■					
SM607A-A08-02	■	■		38.1mm (1.5")			12.7mm (.5")	■	■						
SM607A-A08-02FP	■	■		38.1mm (1.5")			12.7mm (.5")	■		■					
SM607A-A08-02S	■	■		38.1mm (1.5")			12.7mm (.5")	■		■					
SM607A-202-00	■	■		51mm (2")			3mm (.125")	■	■						
SM607A-202-00FP	■	■		51mm (2")			3mm (.125")	■					■		
SM607A-202-00S	■	■		51mm (2")			3mm (.125")	■		■					
SM607A-204-00	■	■		51mm (2")			6mm (.25")	■	■						
SM607A-204-00FP	■	■		51mm (2")			6mm (.25")	■					■		
SM607A-204-00S	■	■		51mm (2")			6mm (.25")	■		■					
SM607A-208-00•	■	■		51mm (2")			13mm (.5")	■	■						
SM607A-208-00FP•	■	■		51mm (2")			13mm (.5")	■					■		
SM607A-208-00S•	■	■		38.1mm (1.5")			12.7mm (.5")	■		■					
SM657A-A08-01•	■	■		38.1mm (1.5")			12.7mm (.5")	■	■						
SM657A-A08-01FP•	■	■		38.1mm (1.5")			12.7mm (.5")	■					■		
SM657A-A08-01S	■	■		38.1mm (1.5")			12.7mm (.5")	■		■					
SM657A-A08-02	■	■		38.1mm (1.5")			12.7mm (.5")	■	■						
SM657A-A08-02FP	■	■		38.1mm (1.5")			12.7mm (.5")	■					■		
SM657A-A08-00S	■	■		51mm (2")			13mm (.5")	■		■					
SM657A-202-00	■	■		51mm (2")			3mm (.125")	■	■						
SM657A-202-00FP	■	■		51mm (2")			3mm (.125")	■					■		
SM657A-202-00S	■	■		51mm (2")			3mm (.125")	■		■					
SM657A-204-00	■	■		51mm (2")			6mm (.25")	■	■						
SM657A-204-00FP	■	■		51mm (2")			6mm (.25")	■					■		
SM657A-204-00S	■	■		51mm (2")			6mm (.25")	■		■					
SM657A-208-00•	■	■		51mm (2")			13mm (.5")	■	■						
SM657A-208-00FP•	■	■		51mm (2")			13mm (.5")	■					■		
SM657A-208-00S•	■	■		51mm (2")			13mm (.5")	■		■					

• = Most commonly stocked sensors

\* = See definition in Sensing Terms.

All possible sensor configurations are not listed here.

## 30 mm Ultrasonic Sensors



DeviceNet™

### **Broad model selections in new SUPERPROX® 30 mm series bring convenience and cost-effective sensing to specific applications**

Using the same world-leading ultrasonic technology perfected and proven in the versatile SUPERPROX® 500 series, three new 30 mm series sensors broaden the list of reliable Hyde Park sensing solutions. With this SUPERPROX® 900 series, the design engineer, maintenance manager, and other professionals can easily select a “smart” ultrasonic sensor specifically configured for an application.

The applications cover those requiring either proximity sensing with on/off output, dual-level sensing with on/off latch control, or continuous level/distance sensing with analog output. Depending on the specific sensing application, 1 meter,

2 meter, and 8 meter sensing range models are available with specific sensing functionality. These models offer a variety of output modes and types, response times, features, and options. Threaded, barrel-style housings, available in either ULTEM® plastic or SS303 stainless steel, make installation quick, especially in those areas where mounting is often difficult. All the 30 mm sensors are CE certified.

For sensing applications requiring connection to a DeviceNet network, all models in this series are available with this capability as an optional selection.

The SUPERPROX® 900 series continues the long tradition of providing sensing solutions where other sensing technologies have not met demanding standards for reliability and productivity. With these 30 mm sensors, the same degree of reliability is assured in the detection of most objects regardless of material.

### **SUPERPROX® Model SM900 Series**

*Proximity sensing with no delay*

### **SUPERPROX® Model SM902 Series**

*Dual-level sensing with on & off latch control*

### **SUPERPROX® Model SM906 Series**

*Level/distance sensing with analog output*

- *Field programmable capability*
- *DeviceNet capability*
- *CE certified*

Harsh environments, high-speed runs, caustic cleaning solutions, and frequent washdowns are often the rule, not the exception, for this rugged, self-contained, sensor line. Like other Hyde Park sensors, this series has protection ratings of IP67 and NEMA 4X, providing resistance to most acids and bases, including most food products. They are sealed against dust, noise, and other hostile environments. Without exception, all three 30 mm series models can be counted on day in and day out for the reliable detection of objects whether they are transparent or opaque, liquid or solid... regardless of color or shape.

## Field Programmable Sensor Models

SUPERPROX+ software combined with the Model AC441A configurator interface module enables the SUPERPROX 900 series sensors to be programmed by the user with either standard or custom sensing configurations. These field programmable sensors use an 'SC' prefix in the model number to designate and differentiate the sensors from factory configured SUPERPROX 900 series models.

All the unique sensing capabilities and functions available in the SUPERPROX SM900, 902, and 906 sensor series are also available in field programmable SC900/906 model versions. An even greater sensing capability in functionality is realized with these field programmable sensor models through the user-friendly SUPERPROX+™ software to allow customization for specific applications.

For more details on the Model SC900 series and other field programmable sensor models along with the Model AC441A configurator interface module go to the SUPERPROX+™ section found on page 4-145 in the catalog.

### Operation

Like the SUPERPROX® 500 series sensors, the 30 mm models are pulse-echo devices that both transmit and receive sonic energy within selected sensing ranges. A unique combination of advanced ultrasonic sensing technology and a discriminating microprocessor and push-button setup program enables the detection of only those objects within a set "window" or span while ignoring all surrounding interference. When the object to be detected is at or within the user-set window limits, either a discrete output switches or an analog output changes proportionally with respect to analog span limits set by the user.

### Easy to Set Up

Convenience in setting up the SUPERPROX® 900 series sensors for operation begins with the ease in which the sensors can be mounted in the proper position. Whether placed in a bracket close to the object or through a vessel cover several feet above the object, the sensor is quickly secured using a pair of jam nuts. Depending on the model series selected, a single push-button at the rear of the sensor is used to set either the near and far window limits, the dual-level limits,

or the analog span limits.

To set the limits, a target or object is placed in front of the sensor successively at the set points representing the desired near (Dwi) and far (Dwo) limits shown in the illustration. When the push-button is pressed at each set point, the respective distances (Dwi and Dwo) from the sensor are stored in the sensor memory to represent the sensing window limits.

For long distances or tall-tank applications, where the long-range (8 meter) sensor's push-button setup is not practical, an optional, hand-held, configuration accessory is available to use in setting the window limits and configuring the sensor's functionality for operation.

Located next to the sensor's push-button is a pair of LEDs. The multicolor LED is used to indicate setup and operational status; the red LED is used to indicate the status of the output.

The sensor outputs, whether discrete or analog, are compatible with most logic control systems and programmable controllers.

### How does it work?

During setup and operation, the SUPERPROX® 900 series sensors continually and accurately measure the elapsed time of every pulse transmission.

### Beam Plots

The following plots, developed from data collected at 20°C, zero air flow, defines the boundaries and shape of the sonic beam for the SUPERPROX® 900 series sensors.

For the 1 and 2 meter series the boundaries were established using a 10 cm x 10 cm (3.94" x 3.94") "target" positioned parallel to the sensor face. The plot for each sensor series is valid for targets equal to or larger than 10 cm x 10 cm. Beam boundaries are determined by moving the large flat

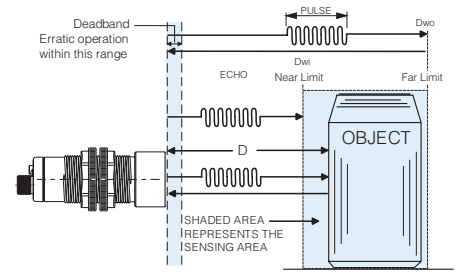

target into the beam while the plane of the target is held perpendicular to the beam axis. The transmitted pulse begins a time clock to determine the elapsed times for the received pulse echoes. Given the elapsed time, the sensor software calculates the distance traveled out to the object and back to the sensor, using the formula,  $D = TV_s/2$ , where  $D$  = distance from the sensor to the object;  $T$  = elapsed time between the pulse transmission and its echo receptions;  $V_s$  = velocity of sound, approximately 1100 feet per second.

During operation, the calculated distance ( $D$ ) between the sensor and the object is compared to the distances between the sensor and the set limits. The operation (discrete and analog) depends on the model number.

### Applications

For applications specific to the three series of SUPERPROX® 900 series sensors, see either the product information sections that follow or the Application/Sensor Selection Chart on Page 2-1.

target into the beam while the plane of the target is held perpendicular to the beam axis.

The same is true for the 8 meter series with the exception that the target is 30 cm x 30 cm (12" x 12").

In each sensor series, the plot extends from the end of the "deadband" on the left to the end of the sensing range on the right. The sensor is illustrated in the middle left margin.

These and other plots are available from Hyde Park upon request.

### SM9XXA-100000

sonic pattern measured by moving a large flat surface into the beam

mm inches

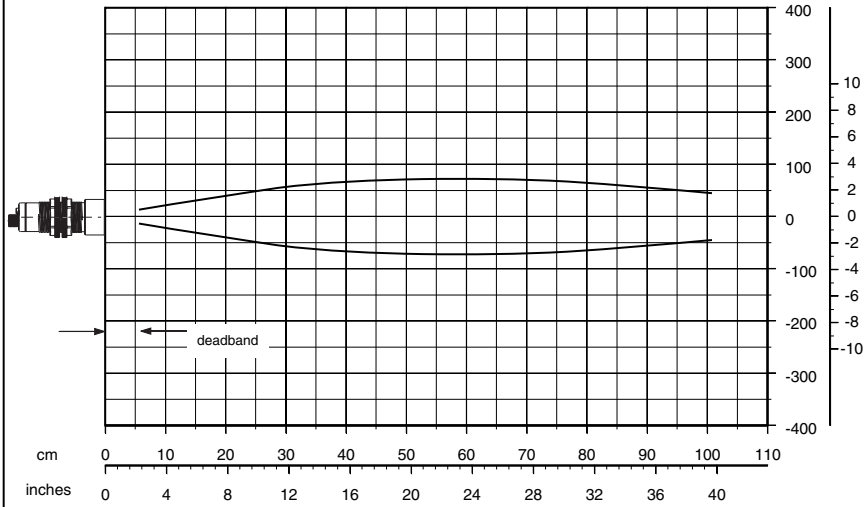

### SM9XXA-400000

sonic pattern measured by moving a large flat surface into the beam

mm inches

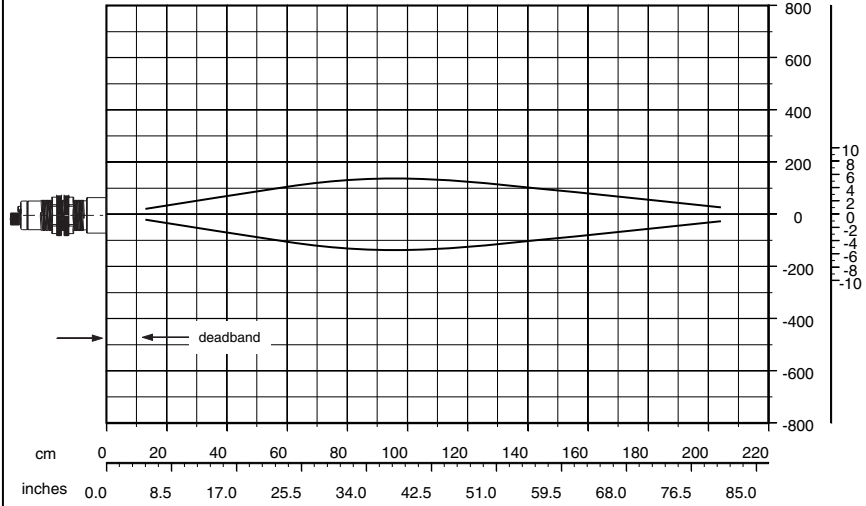

### SM9X0A-800000

sonic pattern measured by moving a large flat surface into the beam

cm inches

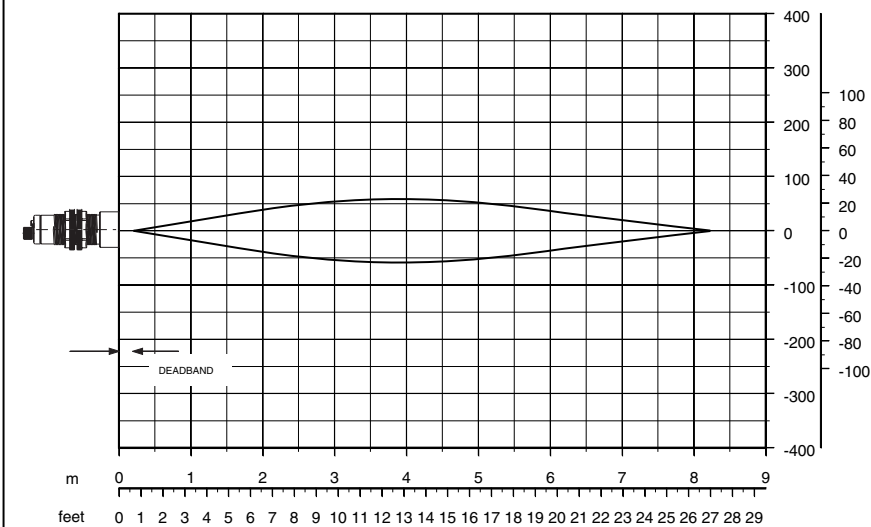

SUPERPROX® SM900  
SERIES INTRO

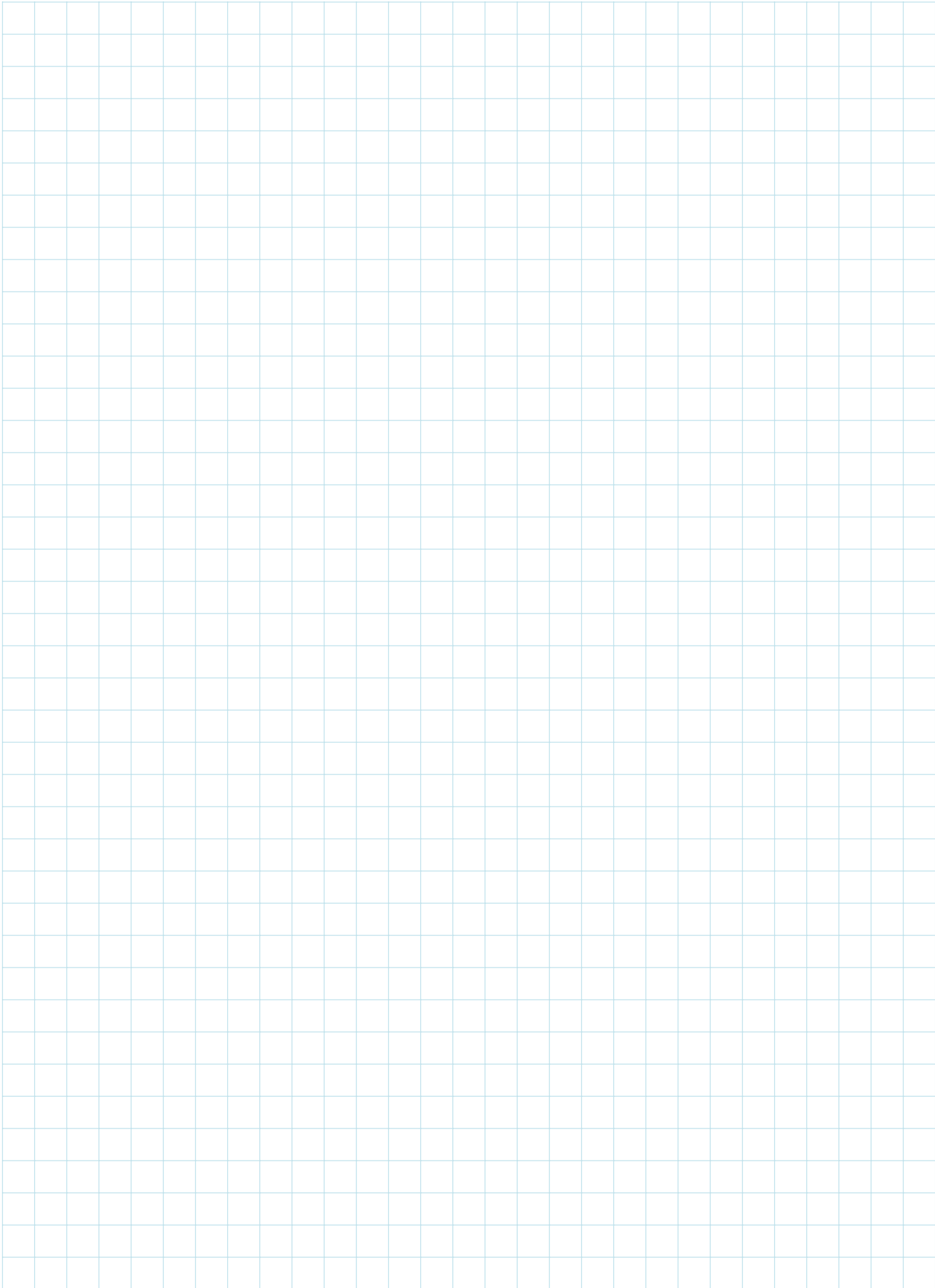

## SUPERPROX<sup>®</sup> Ultrasonic Proximity Sensors

### Up to 8 Meter Range Proximity Sensing

- Sensing ranges of 1 m (39"), 2 m (79"), and 8 m (26')
- Reliable detection with simple on/off control of the output
- Easy push-button setup or optional hand-held setup/display accessory available for all
- Self-contained, 30 mm barrel, in either ULTEM<sup>®</sup> plastic or SS303 stainless steel housing
- Resistant to caustic materials and harsh environments
- Field programmable capability
- DeviceNet capability
- CE certified



DeviceNet<sup>™</sup>

**30 mm ultrasonic proximity sensors offer model selections for range, output type, response time, default window, and transducer face**

Whether the object being detected is just a few inches from the sensor or as far away as 26 feet, or the application calls for a specific sensor configuration, the SUPERPROX<sup>®</sup> Model SM900 series of ultrasonic sensors offers a variety of proximity sensing solutions. There is the mounting convenience of a 30 mm housing, sensing ranges of 1 m (39"), 2 m (79"), and a long-range 8 m (26'), the shortest deadbands in the sensing industry, and unique factory configurability to meet the user's needs. In addition to sensing ranges, model selections include normally-open or normally-closed NPN and PNP outputs, complementary NPN or complementary PNP outputs,

and a variety of response times and default sensing window setup limits. By using the Model Reference Guide to select the specific model required, the user is assured of a reliable, cost-effective proximity sensing solution for a multitude of applications.

All models in this series are equipped with a push-button to set the limits for the sensing "window." When it is impractical to use the push-button for setting long-range sensing limits, an optional, hand-held, setup/display accessory is available. All limits are stored in nonvolatile memory and thus are retained if power is removed from the sensor.

The sensors are available in either ULTEM<sup>®</sup> plastic or SS303 stainless steel housings. Both housings are sealed to withstand dusty, dirty, clean-in-place, noncondensing humidity, high-pressure washdown environments. Unlike other sensing technologies, these sensors are capable of detecting all materials regardless of color, shape, and composition (transparent or

opaque, liquid or solid) including clear glass, powder, food products, metal, plastics, and objects that change colors. They are virtually unaffected by changing light conditions, colors, and noise. Packaged in a 30 mm, threaded housing with jam nuts, the Model SM900 sensors are easily mounted in normally tough-to-install areas of the plant. With protection ratings of NEMA 4X and IP67, the sensors resist most acids, bases, and oils, including most food products. All the sensors in this model series are CE certified. Additionally, the Model SM900 series sensors offer compatible integration with most programmable logic controllers.

## 1 meter and 2 meter models

The standard 1 meter and the 2 meter models are identified in the Model Reference Guide as the Model SM900A-1 and Model SM900A-4 sensors, respectively. These models provide for proximity sensing as close as 50.8 mm (2") from the sensor within the 1 m (39") range and 120 mm (4.7") from the sensor within the 2 m (79") range. To ensure ease of mounting, the length of the connector model, excluding the connector/cable assembly, is just 96 mm (3.78"). These sensors operate on a sonic frequency of 200 kHz and are available with response times as fast as 10 ms. The transducer face is made of FDA approved silicone rubber.

For proximity-sensing applications in severe, corrosive-type environments, the Model SM900A-7STS sensor has an SS303 stainless steel housing and is equipped with an SS304 stainless steel-faced transducer. This model series, with a sensing range of 120 mm to 1 m (4.7" to 39"), provides reliable operation in either the detection of certain chemicals and corrosive materials or where caustic cleaning solutions are used in wash-downs of machinery and equipment in close proximity to the sensor. For out-of-doors, proximity-sensing applications, where cold weather is a factor, this corrosion-resistant model series provides reliable operation in temperatures as low as -10° C (14° F).

## 8 meter, long-range models

No other proximity sensor has as short a deadband, as long a sensing range, and is housed in as small a package as the Model SM900A-8 series of long-range, ultrasonic sensors. Configurable

for long-range proximity sensing applications requiring a simple on/off output, these ultrasonic sensors detect objects of all materials over a sensing range from just 203 mm (8") to 8 m (26'). With the length of the cable model only 116.31 mm (4.579"), a fraction of the length of other long-range sensors, these sensor models are easy to mount

in covers and tight spaces in the plant. They operate on a sonic frequency of 75 kHz with a standard response time of 200 ms. A response time of 100 ms is also available. An epoxy transducer face allows the fully encapsulated sensor to perform in a wide range of harsh environments, including those involving most acids, bases, and oils.

## Model Reference Guide - SM900 Series

Use the guide below to ensure the correct model number is specified for the application. Please note that not all sensor model combinations are available.

EXAMPLE MODEL:

SM9 5 0 A - 1 0 0 000 -

### SUPERPROX® Product Series

#### Power/Connection Type

0...12 to 24 VDC / cable style

5...12 to 24 VDC / connector style

#### Sensing Type

0...Proximity - on/off

#### Design Level

A...Applies to all models

#### Sensing Range

1...51 mm to 1 m (2" to 39")

4...120 mm to 2 m (4.7" to 79")

7...120 mm to 1 m (4.7" to 39") - Required for ST option

8...203 mm to 8 m (8" to 26')

#### Output Type

0...Normally open (N.O.) - NPN & PNP

1...Normally closed (N.C.) - NPN & PNP

2...Complementary NPN outputs

3...Complementary PNP outputs

#### Response Time - On/Off

0...Standard: 25 ms (1 m) / 35 ms (2 m) / 250 ms (8 m)

1...Fast: 10 ms (1 m) / 15 ms (2 m) / 100 ms (8 m)

2...100 ms (1 m/2 m)

3...250 ms (1 m/2 m)

5...1.000 s (1 m/2 m/8 m)

4...500 ms (1 m/2 m/8 m)

6...2.500 s (1 m/2 m/8 m)

#### Functionality

000...Standard default window: ± 6.35 mm (0.25") (1 m/2 m);  
± 63.5 mm (2.50") (7.6 m)

001...Default window: ± 12.7 mm (0.50") (1 m/2 m)

002...Default window: ± 25.4 mm (1.00") (1 m/2 m)

003...Default window: ± 2.54 mm (0.10") (1 m/2 m)

004...Default window: ± 9.52 mm (0.375") (1 m/2 m)

090...Default window: ± 51 mm (2.00") (1 m/2 m)

#### Options

...No designator indicates no options (standard)

ST...Stainless transducer (must also specify stainless housing; available in 120 mm to 1 m models only)

FS...Fluorosilicone transducer face (1 m models only)

AD...Limits push-button disabled

OB...Object mode

#### Housing Types

...No designator indicates standard ULTEM® plastic housing (standard)

S...SS303 stainless steel (1 and 2 m models only)

\* ULTEM® is a registered trademark of The General Electric Company.

Field configurable and DeviceNet Model Reference Guides start on page 4-145.



## Applications

Applications for these long-range proximity sensors extend to most every industry or business requiring reliable detection within the range of 8 meters (26 feet). By virtue of the 75 kHz frequency, the sensor's wide, 20° beam is especially effective in detecting objects with a variety of surface profiles. In applications where high sound absorption conditions exist in the material being sensed, and either the one or two meter range model sensor becomes unreliable because of lost energy, the more powerful long-range SM900A-8 can provide the solution when used in the shorter-range distances.

Temperature compensation allows these sensors to operate reliably in outdoor applications in temperatures ranging from -10° to 60° C (14° to 140° F).

## Operation

The SUPERPROX® Model SM900 series is a self-contained, pulse-echo, proximity sensing device that both transmits and receives sonic energy within specified sensing ranges. Operating on 12 to 24 VDC, and employing the latest piezoelectric and microprocessor technology, these sensors detect only those designated objects within a set "window" and ignore all surrounding sonic interference.

Prior to operation, a simple and easy push-button "teach" function is used to set the sensing window limits. The near and far limits of a desired sensing window can be set anywhere within the sensing range and may be set to either encompass the full sensing range or be as small as desired. The push-button setup allows a window to be set as small as 2.54 mm (0.10") within the 1 and 2 m ranges and, depending on ambient conditions, a window within the 8 m range can be as small as 102 mm (4.0"). A double press of the SETUP push-button makes possible the setting of a default window anywhere within the sensing range.

The sensors are equipped with a multi-color sensing status LED and a red LED. The red LED shows the state of the output. When the output is active, the red LED is on. When the output is not active, the red LED is off. The multicolor LED indicates the position of the object relative to the sensing window limits: green when the object is inside the window; red when the object is outside the window; and off when the object is outside the sensing range.

Two different sensing program configurations, both employing fore-

ground and background suppression, are available in the SM900 series, depending on the sensing application.

The standard sensing configuration, used in most proximity sensing applications, calls for the sensor to operate in a "background sensing mode." In this mode, the sensor can detect objects either directly or retroreflectively by doing a break-beam technique with a fixed background target. When objects are of irregular shape or non-repeatable orientation, break-beam sensing with a fixed background target should be used. After the sensing window is set to sense an object or the background target, the sensor continually transmits sonic pulses.

When the first pulse echo is received after each transmission pulse, the sensor shuts off its receiver and interrogates the elapsed travel time of the received first echo to determine whether the object is in or out of the sensing window. The sensor's receiver then waits for the next echo to interrogate. When either no echo is received, or the first echo received off an object travels a lesser or greater distance than the window distance, the sensor determines there is no object present. When sensing objects by break-beam with a fixed background target, the sensor determines there is no object present whenever receiving echoes off the background target.

An optional "object sensing mode" configuration is recommended when the sensor must sense objects beyond a foreground surface having an opening that permits reception of the pulse echoes. An example would be the sensing of an object through a grid or inside a narrow opening. Sensing in this mode is done by setting the sensing window limits beyond the foreground surface. During operation, the sensor receives all pulse echoes from objects in front of it, including the foreground surface, without interruption. But, in this mode, the discriminating microprocessor permits the sensor to accept only those pulse echoes from objects that are within the sensing window limits and ignore any foreground objects.

**Exception:** Multiple echoes received off objects at either 1/2 or 1/4 distances from the sensor to the window may be accepted or confused as an object in the sensing window. This is avoided by mounting the sensor in a position where this condition cannot exist.

## Setting the Window Limits

Located on the backside of the sensor, the SETUP push-button is used to set both the near and far window limits within which the sensing is to take place. Before the limits are set, the sensor must be properly aligned with the object to be detected.

To set the near and far limits, depress the SETUP push-button (the multicolor LED rapidly flashes amber to indicate the push-button is being pressed) until the multicolor LED flashes green in about 3 seconds, and then release the SETUP push-button. The multicolor LED continues flashing green indicating the sensor is waiting for the first window limit. Align a flat object parallel to the sensor face at the desired distance position for either (near or far) window limit, and press the SETUP push-button once. Upon release of the SETUP push-button, the multicolor LED flashes amber indicating the first window limit is set and the sensor is waiting for the second window limit. Align a flat object parallel to the sensor face at the desired position for the second window limit and press the SETUP push-button once. Upon release of the SETUP push-button, the multicolor LED turns to the color that indicates where the object is located. The sensor has no time-out for setting limits.

While the SETUP push-button is depressed in setting either the first or second window limit, the multicolor LED will turn amber to indicate the sensor detects the object. If the sensor does not detect the object, the multicolor LED will turn red while the push-button is depressed and flash red 2 seconds when it is released. After the LED flashes red 2 seconds, it will either flash green if the sensor is requesting the first window limit again or flash amber if the sensor is requesting the second window again.

A special feature of these sensors allows the user to set an automatic default window of fixed size anywhere within the sensing range. For the 1 and 2 meter range models, the standard default window is 12.7 mm (0.50"). It is 127 mm (5.00") for the 8 meter range models. Other default window sizes are available for all the models upon request. To easily set the default window, while the multicolor LED is flashing green, align a flat object parallel to the sensor face at the center of the desired window and press the SETUP push-button twice in succession without moving the object. An automatic default

window limit will be set at a distance equal to half the default window in front of and behind the flat-object surface nearest the sensor. If, for example, the functionality of the 1 or 2 meter range sensor calls for the standard default window, the sensing window is set with limits 6.35 mm (0.25") in front of and behind the object's front surface.

For long distances or tall-tank applications, when the sensor's push-button is not practical, an optional, Model AC441A Handheld Configurator can be used to set or change the near and far window limits and display the object distance when the sensor is located up to 200 feet from the user. The Model AC441A cannot, however, be used to set the default window.

Once set, the window limits are saved in nonvolatile memory and thus are retained when power is removed from the sensor.

### How Does it work?

During setup and operation, these SM900 series sensors continually and accurately measure the elapsed time of every pulse echo reception between each pulse transmission. The transmitted pulse begins a time clock to register the elapsed times for the received pulse echoes. Given the elapsed time, the sensor software calculates the distance traveled out to the object or surface and back to the sensor, using the formula,  $D = Tv_s/2$ , where:  $D$  = distance from the sensor to the object;  $T$  = elapsed time between the pulse transmission and its echo receptions,  $V_s$  = the velocity of sound, approximately 1100 feet per second.

During operation, the calculated distance ( $D$ ) between the sensor and the object is compared to the distances associated with the window limits. These limits are shown in the illustration at lower right as  $D_{wi}$  and  $D_{wo}$ .

If  $D$  is within these limits, an output is generated. The output remains on until the echo does not return or it returns from outside the window limits.

## Electrical Wiring

The sensor wires must be run in conduit free of any AC power or control wires.

### Cable/Connector Wire Colors and Outputs

Cable Model Wire Assignments

Sinking/Sourcing N.O./N.C.

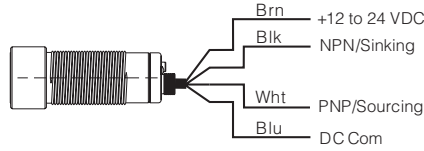

Complementary Sinking

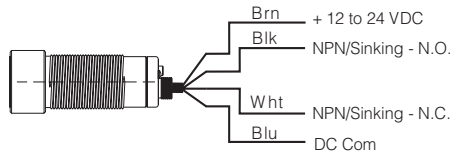

Complementary Sourcing

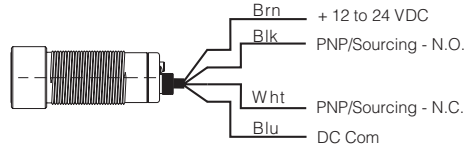

Connector Model Pin Assignments

Sinking/Sourcing N.O./N.C.

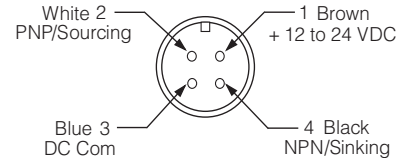

Complementary Sinking

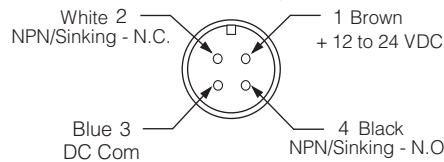

Complementary Sourcing

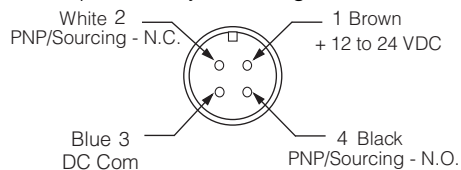

### NPN/Sinking and PNP/Sourcing Outputs

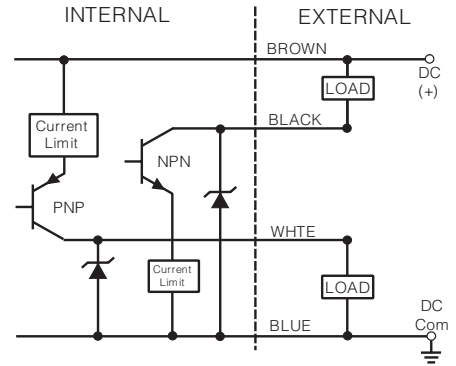

### Complementary NPN/Sinking Outputs

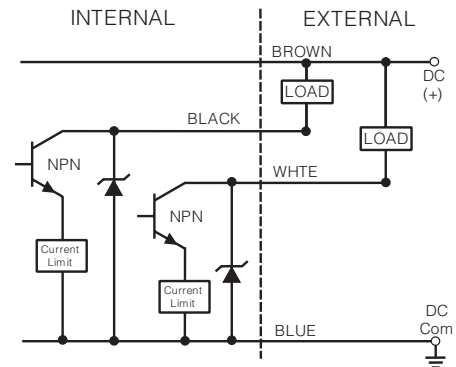

### Complementary PNP/Sourcing Outputs

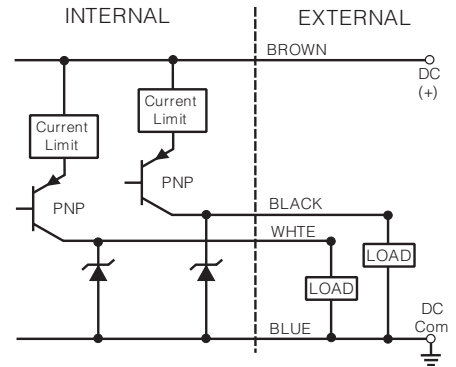

### Calculating Pulse Transmission

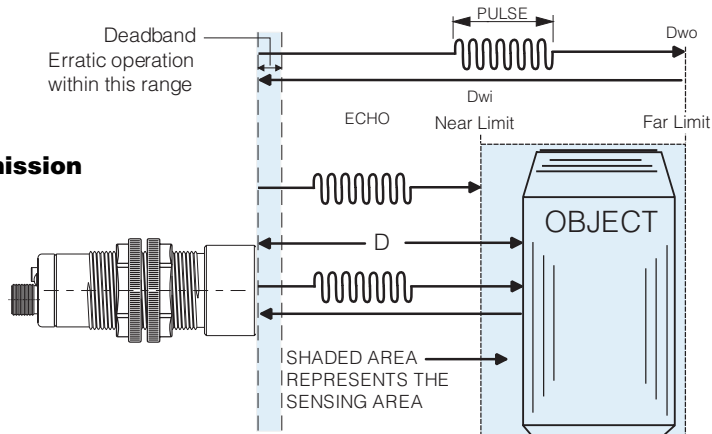

## Dimensions

### Cable Style

(ULTEM® plastic and SS303 stainless steel)

SM900A-1, SM900A-4, SM900A-7STS

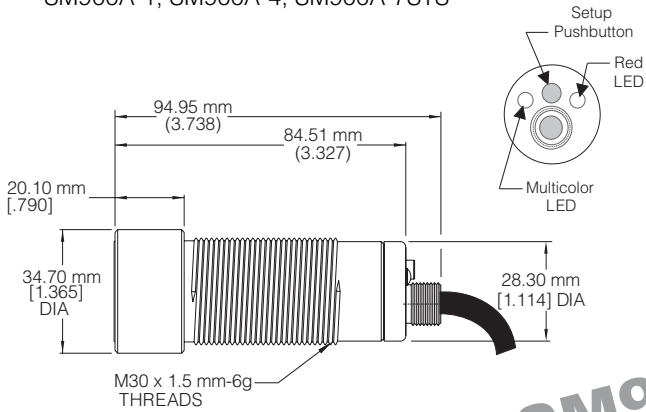

### Cable Style

(ULTEM® plastic & SS303 stainless steel)

SM900A-8 Long-range

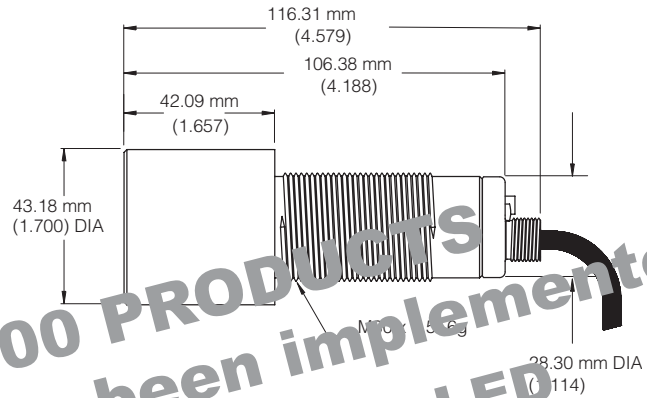

### Connector Style

(ULTEM® plastic and SS303 stainless steel)

SM950A-1, SM950A-4, SM950A-7STS

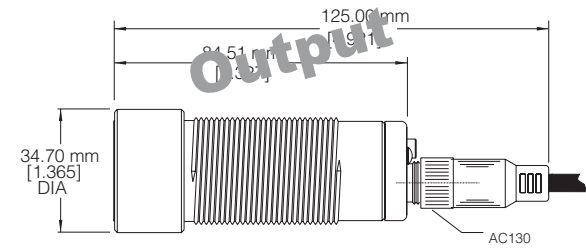

### Connector Style

(ULTEM® plastic & SS303 stainless steel)

SM950A-8 Long-range

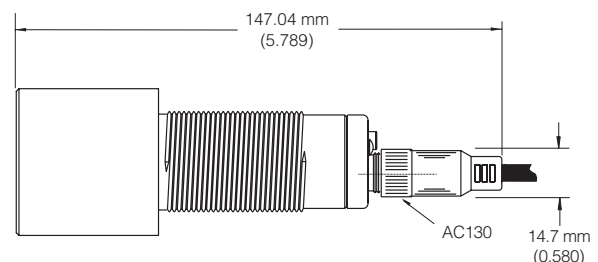
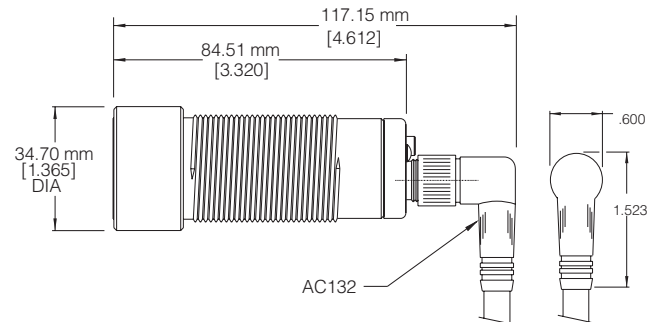
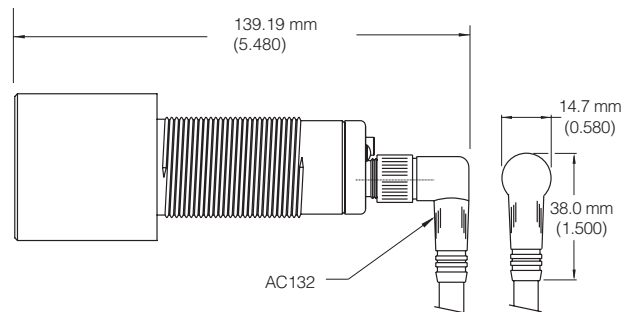
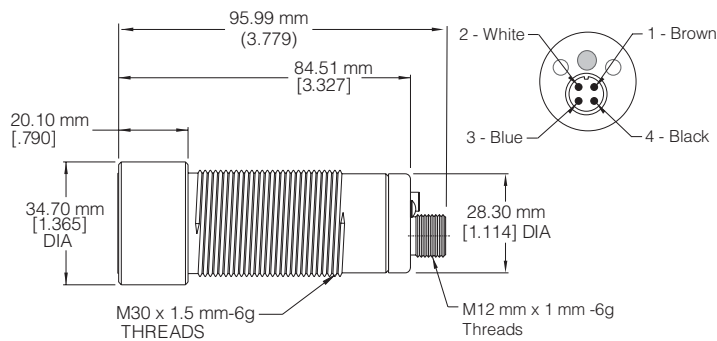
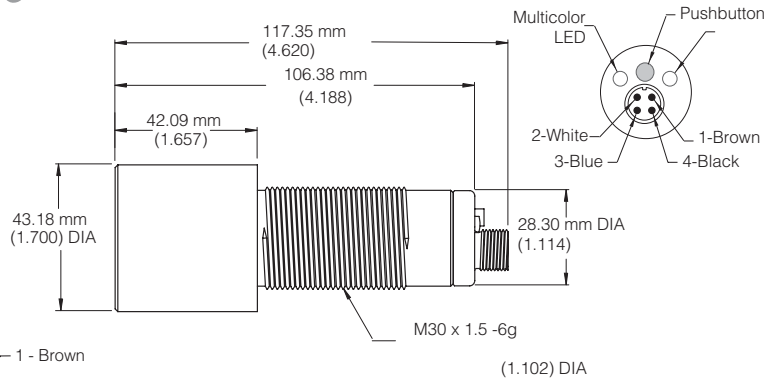

FOR ALL SM900 PRODUCTS  
LED color change has been implemented  
Current LED New LED  
Red Amber

SUPERPROX® SM900  
SERIES

## Accessories

**AC130** Straight, M12 micro, 4-conductor, connector/cable assembly, 5 m (16'), for 30 mm, barrel-style sensors

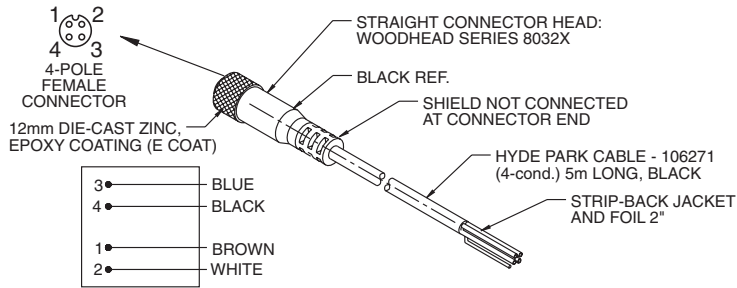

**AC132** Right-angle, M12 micro, 4-conductor, connector/cable assembly, 5 m (16'), for 30 mm, barrel-style sensors

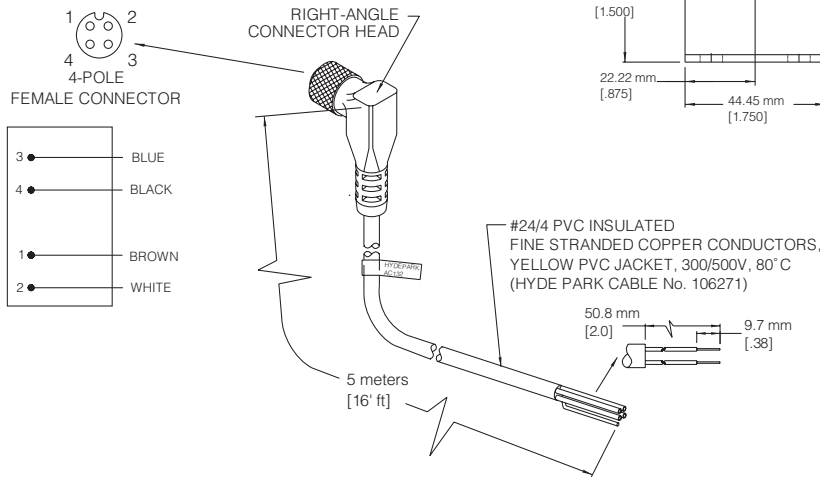

**AC233** Small, right-angle, stainless mounting bracket for 30 mm, barrel-style sensors

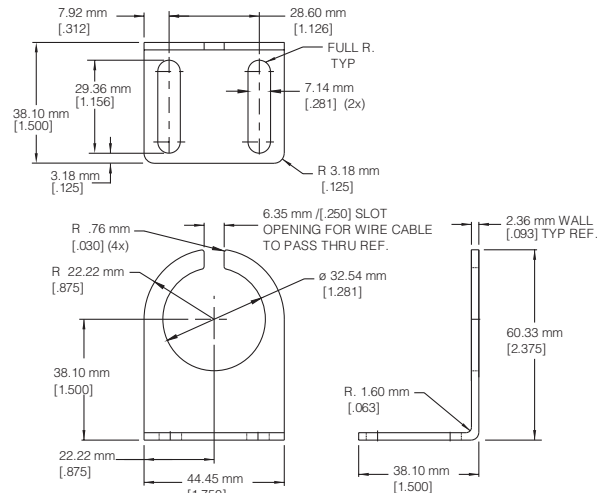

## General Specifications

### Sensing [TA = 20° C (68° F)]

#### 1 and 2 meter ranges

Model Sensing Ranges  
 51 mm to 1 m (2.0' to 39")  
 120 mm to 1 m (4.7 to 39")\*\*  
 120 mm to 2 m (4.7 to 79")

Sonic Frequency: 200 kHz

Minimum-size Detection

(Model SM900A-1):

1.59 mm (0.0625") diameter rod up to 635 mm (25") distance from sensor

Maximum Angular Deviation:

± 10° on 305 mm x 305 mm (12" x 12") flat target at a distance of 305 mm (12")

Sonic Cone Profile: See Beam Plots, Page 4-109

Limit Adjustment Resolution: 0.08 mm (0.003")

Repeatability: ± 0.8716 mm (0.03431") max.

Temperature Compensated

### Power Requirements

Supply Voltage:

12 to 24 VDC ± 10% excluding output load (regulated supply)

Current Consumption: 100 mA max., excluding load

Peak Inrush Current: 0.50 Amp

Power Consumption: 1.2 W max., excluding load

### Outputs

Sinking Output (NPN):

Maximum on-state voltage @ 100 mA: 0.37 volt

Maximum load current: 100 mA

Maximum applied voltage: 35 VDC

Sourcing Output (PNP):

Maximum on-state voltage drop @ 100 mA:

0.50 volt

Maximum load current: 100 mA

### Response Times -

#### Minimum, Standard

10 ms on/off, 20 ms on/off (1 m range models)

15 ms on/off, 30 ms on/off (2 m range models)

Other response times are available.

### Indicators

Multicolored (Amber, Red, Green)

LED: Indicates limits setup and operational modes.

Red LED:

Visual indicator for sensor output; illuminated when output is in an active (on) state.

### Connection Options

Cable Style:

24 AWG, foil shield, lead-free PVC jacketed, 4-conductor, 3 meters (10') long, standard

Connector Style: 12 mm, 4 pole, male

### Protection

Power Supply: current-limited over-voltage, ESD, reverse polarity

Outputs: current-limited over-voltage, ESD, over-current

**NOTE:** This sensor is NOT RATED EXPLOSION PROOF.

### Environmental

Operating Temperature Range:

0° to 50°C (32° to 122°F) for

silicone-faced models

-20° to 50°C (-4° to 122°F) for stainless

steel-faced models

Storage Temperature Range:

-20° to 80°C (-4° to 176°F) for

silicone-faced models

-50° to 80°C (-58° to 176°F) for

stainless steel-faced models

Operating Humidity: 100%

Protection Ratings: NEMA 4X, IP67

Chemical Resistance: Unaffected by most acids, bases, and oils.

Fluorosilicone- and stainless steel-faced transducers available for severe, corrosive-type environments.

### Construction

Dimensions:

Cable Model: 30 mm (1.181") dia. x 1.5 mm-6g threaded housing x 94.95 mm (3.738") mm long, including 34.70 mm

(1.365") dia. x 20.10 mm (0.790") long sensing head

Connector Model: 30 mm (1.181") dia x 1.5 mm-6g threaded housing x 95.99 mm (3.779") long; 117.15 mm (4.612") long, including AC 132 right-angle, M12 micro, connector/cable assembly; 125.00 mm (4.921") long, including AC130 straight, M12 micro, connector/cable assembly; sensing head dimension same as cable model.

**Housing:**

Epoxy encapsulated to resist shock and vibration

**Case:**

ULTEM® plastic (FDA Approved) or SS303 stainless steel

**Transducer Face:**

Silicone rubber - gray  
SS304 stainless steel, 0.051 mm (0.002") thick\*\*

Sensor Cables: Lead-free, black PVC jacketed

**Agency Approvals**

CE Mark: CE conformity is declared to:  
EN61326:1997 (annex A, industrial) including amendment A1:1998, EN55011 Group 1 Class A  
*Declaration of Conformity available upon request*

**8 meter, long range**

Model Sensing Range:

203 mm to 8 m (8.0" to 26')

Sonic Frequency: 75 kHz

Minimum-size Detection (Model SM900A-8):

50.8 mm (2.0") diameter rod up to 4572 mm (15') distance from the sensor

Maximum Angular Deviation:

± 10° on a large flat surface at a distance of 6.096 m (20')

± 5° on a large flat surface at a distance of 8 m (26')

Sonic Cone Profile: See Beam Plots, Page 4-109

Limit Adjustment Resolution: 0.254 mm (0.01")

Repeatability: ± 2.54 mm (0.10") max.

Temperature Compensated

**Power Requirements**

Supply Voltage:

12 to 24 VDC ± 10% excluding output load (regulated supply)

Current Consumption: 100 mA max., excluding load

Peak Inrush Current: 0.50 Amp.

Power Consumption: 1.2 W max., excluding load

**Outputs**

Sinking Output (NPN):

Maximum on-state voltage @ 100 mA: 0.37 volt

Maximum load current: 100 mA

Maximum applied voltage: 35 VDC

Sourcing Output (PNP):

Maximum on-state voltage drop @

100 mA: 0.50 volt

Maximum load current: 100 mA

**Response Times -**

**Minimum, Standard**

100 ms on/off, 200 ms on/off

Other response times are available.

**Indicators**

Multicolored (Amber, Red, Green) LED:

Indicates limits setup and operational modes.

Red LED:

Visual indicator for sensor output; illuminated when output is in an active (on) state.

**Connection Options**

Cable Style:

24 AWG, foil shield, lead-free PVC jacketed, 4-conductor, 3 meters (10') long, standard

Connector Style: 12 mm, 4 pole, male

**Protection**

Power Supply: current-limited over-voltage, ESD, reverse polarity

Outputs: current-limited over-voltage, ESD, over-current

**NOTE:** This sensor is NOT RATED EXPLOSION PROOF.

**Environmental**

Operating Temperature Range: - 20° to 60°C (-4° to 140°F)

Storage Temperature Range: -40° to 100°C (-40° to 212°F)

Operating Humidity: 100%

Protection Ratings: NEMA 4X, IP67

Chemical Resistance: Unaffected by most acids, bases, and oils.

**Construction**

Dimensions:

Cable Model: 30 mm (1.181") dia. x 1.5 mm-6g threaded housing x 116.31 mm (4.579") mm long, including 43.18 mm (1.700") dia. x 42.09 mm (1.657") long sensing head

Connector Model: 30 mm (1.181") dia x 1.5 mm-6g threaded housing x 117.35 mm (4.620") long; 139.19 mm (5.480") long, including AC132 right-angle, connector/cable assembly; 147.04 mm (5.789") long including AC130 straight, connector/cable assembly; sensing head dimension same as cable model.

Housing: Epoxy encapsulated to resist shock and vibration

Case: ULTEM® plastic (FDA Approved)

Transducer Face: Epoxy - white

Sensor Cables: Lead-free, black PVC jacketed

**Agency Approvals**

CE Mark: CE conformity is declared to:

EN61326:1997 (annex A, industrial) including amendment A1:1998, EN55011 Group 1 Class A

*Declaration of Conformity available upon request*

\* ULTEM® is a registered trademark of The General Electric Co.

\*\*Available only in the stainless steel-faced, 1 m range models

**Accessories**

**Model AC130**, Straight, M12 micro, 4-conductor, connector/cable assembly, 5 m (16')

**Model AC132**, Right-angle, M12 micro, 4 conductor, connector/cable assembly, 5 m (16')

**Model AC233**, Small, right-angle, stainless, mounting bracket

**Model AC250-n**, Tank sensor mounting reducer, available with four different outside diameters; used with all SUPERPROX® SM900 family sensors. n = 1 (1 1/4" NPT); 2 (2" NPT); 3(3" NPT); 4(4" NPT)

**Model AC251-n**, Tank sensor mounting flange, available with three different pipe thread diameters, furnished with matching AC250 Tank sensor mounting reducer; used with all SUPERPROX® SM900 family sensors. n = 2 (2" NPT); 3(3" NPT); 4(4" NPT)

**Model AC441A**, Handheld Configurator

See Page 7-1 for accessory photos.

LED color change has been implemented  
New LED Amber

SUPERPROX® SM900 SERIES

# Selection Chart

## SM900 Series Proximity

Model No.	Power Version 12/24 VDC		Connection Style		Sensing Range				Transducer Materials				Housing		Output Type			Response Time	Default Window	Special Features
	Cable	Connector	51 mm - 1 m. 2" - 39"	120 mm - 2 m 4.7" - 79"	120 mm - 1 m 4.7" - 39"	203 mm - 7.6 m 8" - 25"	Silicone	Stainless	Fluorosilicone	Epoxy	30 mm ULTEM®	30 mm stainless	N.O. NPN & PNP	N.C. NPN & PNP	Complementary NPN	Complementary PNP				
SM900A-100000	■	■	■					■		■							20 ms	± 0.25"		
SM900A-100000FS	■	■	■						■								20 ms	± 0.25"		
SM900A-100000OB	■	■	■					■									20 ms	± 0.25"	Object Proximity Model	
SM900A-100000S	■	■	■								■						20 ms	± 0.25"		
SM900A-101000OB	■	■	■														10 ms	± 0.25"	Object Proximity Model	
SM900A-110000	■	■	■												■		20 ms	± 0.25"		
SM900A-120000	■	■	■												■		20 ms	± 0.25"		
SM900A-120001	■	■	■												■		20 ms	± 0.50"		
SM900A-130000	■	■	■													■	20 ms	± 0.25"		
SM900A-130000OBS	■	■	■												■		20 ms	± 0.25"	Object Proximity Model	
SM900A-400000	■	■		■													30 ms	± 0.25"		
SM900A-400000OB	■	■		■													30 ms	± 0.25"	Object Proximity Model	
SM900A-400000S	■	■		■													30 ms	± 0.25"		
SM900A-420000	■	■		■											■		30 ms	± 0.25"		
SM900A-700000STS	■	■			■				■								20 ms	± 0.25"		
SM900A-800000	■	■					■			■							200 ms	± 2.50"		
SM950A-100000	■		■	■													20 ms	± 0.25"		
SM950A-100000FS	■		■	■													20 ms	± 0.25"		
SM950A-100000OB	■		■	■													20 ms	± 0.25"	Object Proximity Model	
SM950A-100000S	■		■	■							■						20 ms	± 0.25"		
SM950A-100001	■		■	■													20 ms	± 0.50"		
SM950A-100002	■		■	■													20 ms	± 1.00"		
SM950A-100003	■		■	■													20 ms	± 0.10"		
SM950A-100003OB	■		■	■													20 ms	± 0.10"	Object Proximity Model	
SM950A-100005	■		■	■													20 ms	± 0.125"		
SM950A-101000	■		■	■													10 ms	± 0.25"		
SM950A-101000S	■		■	■													10 ms	± 0.25"		
SM950A-102200	■		■	■													100 ms	± 0.25"		
SM950A-110000	■		■	■											■		20 ms	± 0.25"		
SM950A-110000S	■		■	■											■		20 ms	± 0.25"		
SM950A-110003	■		■	■											■		20 ms	± 0.10"		
SM950A-115001	■		■	■											■		1.0 s	± 0.50"		
SM950A-120000	■		■	■												■	20 ms	± 0.25"		
SM950A-120000S	■		■	■												■	20 ms	± 0.25"		
SM950A-120003OBS	■		■	■												■	20 ms	± 0.10"	Object Proximity Model	
SM950A-130000	■		■	■												■	20 ms	± 0.25"		
SM950A-130000OB	■		■	■												■	20 ms	± 0.25"	Object Proximity Model	
SM950A-400000	■			■													30 ms	± 0.25"		
SM950A-400000S	■			■													30 ms	± 0.25"		
SM950A-401002	■			■													15 ms	± 1.00"		
SM950A-402000	■			■													100 ms	± 0.25"		
SM950A-410000	■			■											■		30 ms	± 0.25"		
SM950A-420000	■			■												■	30 ms	± 0.25"		
SM950A-430000	■			■												■	30 ms	± 0.25"		
SM950A-430000S	■			■												■	30 ms	± 0.25"		
SM950A-700000STS	■				■												20 ms	± 0.25"		
SM950A-800000	■						■										200 ms	± 2.50"		

\* ULTEM® is a registered trademark of The General Electric Co.  
All possible sensor configurations are not listed here.

### SUPERPROX® Ultrasonic Dual- level Sensors

#### Up to 8 Meter Range Dual- Level Sensing

- Sensing ranges of 1 m (39"), 2 m (79"), and 8 m (26')
- Easy push-button setup or optional hand-held setup/display accessory available for all
- Dual-level on/off latch output
- Dual setpoint on/off outputs
- Epoxy sealed in tough ULTEM® plastic or stainless steel housing
- Resistant to caustic materials and harsh environments
- Field programmable capability
- DeviceNet capability
- CE certified



DeviceNet.

#### Up to 8 meter (26 feet) level control, mounting convenience and broad functionality in this new 30 mm, dual-level sensor series

The world's leading ultrasonic technology now makes possible discrete level control in vessels, tanks, hoppers, bins, and reservoirs, covering object distances a few inches from the sensor to as far away as 26 feet. Depending on the model selected and material being detected, the SUPERPROX® Model SM902 series of "smart" dual-level sensors offers sensing ranges of 1 m (39"), 2 m (79"), and a long-range 8 m (26'), with the shortest deadbands in the sensing industry of 51 mm (2"), 120 mm (4.7"), and 203 mm (8"), respectively.

In addition to range selection, the sensors can be factory configured for a specific level-

control function, output type, response time, and functionality. Using these selections, an ideal solution can be found for such operations as: starting and stopping a pump and opening and closing a valve. Others include controlling either loop levels or tension on web processing lines relative to two set level control limit points.

Packaged for mounting convenience in a threaded, 30 mm housing, 60% smaller than other level sensors with equal functionality, these dual-level sensors are easily installed, without positioning limitations, in covers and other hard-to-mount areas. All models are equipped with a push-button to set the sensor's near and far limits of the sensing "window." When it is impractical to use the push-button for setting long-range limits, an optional, hand-held, setup/display accessory is available. All limits are stored in nonvolatile memory and thus are retained if power is removed

from the sensor.

Unlike other sensing technologies, these sensors are capable of detecting all materials, liquid, granular, and solid, regardless of color, shape, and composition, transparent or opaque, including powder, food products, grains, chemicals, pharmaceuticals, oils, plastics, and objects that change colors. The sensors are available in either ULTEM® plastic or SS303 stainless steel housings which are fully encapsulated to withstand shock and vibration. Both are sealed to withstand dusty, dirty, clean-in-place, noncondensing humidity, high-pressure washdown environments, and they are virtually unaffected by changing light conditions, colors, and noise. With housings that meet NEMA 4X and IP67 industry standards, the sensors resist most acids, bases, and oils, including most food products. All the sensors in this model series are CE certified. Additionally, the Model SM902 series sensors offer dependable operation and compatible integration with most programmable logic controllers.

### 1 meter and 2 meter range models

In the Model Reference Guide, the standard 1 meter range models are identified as the Model SM902A-1 and SM952A-1 series sensors, and the 2 meter range models are identified as the Model SM902A-4 and SM952A-4 series sensors. Respectively, these models provide for dual-level sensing from 50.8 mm to 1 m (2" to 39") and 120 mm to 2 m (4.7" to 79"). The length of the connector model, excluding the connector/cable assembly, is just 96 mm (3.78"), thus adding to the mounting convenience. These sensors operate on a sonic frequency of 200 kHz and are available with response times as fast as 150 ms. The FDA approved silicone rubber transducer face, while used to couple the ultrasonic energy to the air, is also resistant to most acids, bases, oils, and food products.

For dual-level-control sensing applications that involve severe, corrosive-type environments, the Model SM902A-7STS and SM952A-7STS sensors have an SS303 stainless steel housing with an SS304 stainless steel-faced transducer. These models, with a sensing range of 120 mm to 1 m (4.7" to 39"), provide reliable operation in the detection of certain strong chemicals and corrosive materials, and where caustic cleaning solutions are used in washdowns of machinery and equipment in close

proximity to the sensor. For out-of-doors, dual-level-control sensing applications, where cold weather is a factor, these corrosion-resistant models provide reliable operation in temperatures as low as -10°C (14°F).

Non-level control applications ideally suited for these sensors within the 1 and 2 meter ranges include: container accumulation detection on mass conveyors and controlling either loop positions or tension on web processing lines relative to two set control limits.

### 8 meter, long-range models

No other discrete, level-control sensor on the market has as short a deadband, as long a sensing range, and is housed in as small a package as the Model SM902A-8 and Model SM952A-8 series of long-range, ultrasonic, dual-level sensors. As indicated in the Model Reference Guide, these 30 mm sensors detect objects over a sensing range of just 203 mm (8") to 8 m (26'). The 116.31 mm (4.579") length of the cable model, a fraction of the size of other long-range sensors, ensures easy installation. The sensors operate on a sonic frequency of 75 kHz with a standard response time of 1 second, with other response times available. The transducer face of the fully encapsulated sensor is made of epoxy which, in addition to coupling the ultrasonic energy to the air, allows the sensor to perform in a wide range of harsh environments including those involving most acids, bases, and oils.

Applications for these long-range, dual-level sensors can be found in almost every industry or business when reliable detection within the range of 8 meters (26 feet) is required. By virtue of the 75 kHz sonic frequency, the sensor's wide, 20° beam is especially effective in sensing the levels of various types of liquids, solids, and granules as close as 203 mm (8") from the sensor's face. These applications include the processing of food and beverage products and pharmaceuticals, as well as the treatment of water and sewage. In the sensing of dry materials, such as grains and powders, the long-range, dual-level sensors offer an efficient alternative to certain limit switch devices, which can be prone to frequent maintenance problems and unreliable operation.

In applications where high sound absorption conditions may exist in the material being detected, and either the one or two meter range model sensor becomes unreliable because of lost

energy, the more powerful long-range SM902 can provide the solution when used within the sensing ranges of either one or two meters.

Temperature compensation allows these long-range sensors to operate reliably in outdoor applications in temperatures ranging from -20° to 60°C (-4° to 140°F).

### Operation

The SUPERPROX® Model SM902 series sensor, operating on 12 to 24 VDC regulated power, is a self-contained, pulse-echo, dual-level, sensing device that monitors and controls most nonhazardous material levels within the specified sensing ranges. With extremely short deadbands, the sensors are capable of detecting levels of liquids, solids, and powders as high as 51 mm (2") from the sensor face.

Before operation, a push-button "teach" function is used to set the sensing window limits. The near and far limits of a desired sensing window can be set anywhere within the sensing range and may be set to encompass the full sensing range or be as small as desired. A double press of the SETUP push-button, makes possible the setting of a default window anywhere within the sensing range.

Functionality in the operation of the 30 mm, long-range sensors includes the capability to be configured for various NPN and PNP, normally open, normally closed or complementary output modes for: pump-in latch or pump-out, with and without alarm or setpoint, and dual alarm/dual setpoint operations. A loss-of-echo feature can be selected to hold the output in the event of a loss-of-echo condition.

During setup and operation, a multicolor LED indicates the limits setup and operational modes; a red LED illuminates when the output is in an active (on) state.



## How does it work?

During setup and operation, these SM902 series sensors continually and accurately measure the elapsed time of every pulse echo reception between each pulse transmission. The transmitted pulse begins a time clock to register the elapsed times for the received pulse echoes. Given the elapsed time, the sensor software calculates the distance traveled out to the object or surface and back to the sensor, using the formula,  $D = TVs/2$ , where  $D$  = distance from the sensor to the object;  $T$  = elapsed time between the pulse transmission and its echo receptions;  $V$  = the velocity of sound, approximately 1100 feet per second.

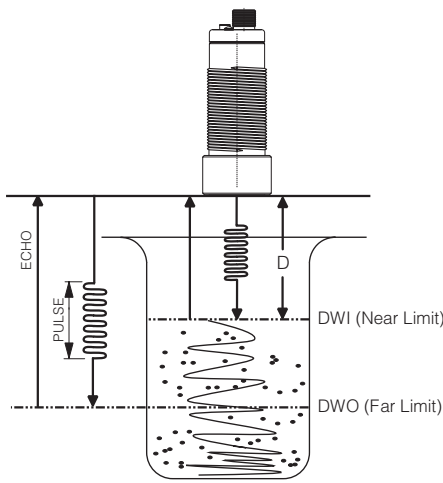

During operation, the calculated distance ( $D$ ) between the sensor and the object (e.g., level) is compared to the distance between the sensor and the near and far limits. These limits are shown in the illustration above as  $D_{wi}$  and  $D_{wo}$ . When  $D$  is equal to one of the two limits, according to the level-control functions, an output change takes place. A red LED illuminates when the output is in an active (on) state.

## Level-Control Functions

The level control output in the Model SM902 series can be configured for many different operating functions. Through the Model Reference Guide, the sensor can be selected to perform a pump-in latch function, pump-out latch function, dual-setpoint function, dual alarm, or a combination of these functions.

### Pump-in Latch

When the level moves farther than the far limit, the sensor level control output switches state and latches, starting a pump-in process. The sensor level control output does not change state

## Model Reference Guide - SM902 Series

Use the guide below to ensure the correct model number is specified for the application. Please note that not all sensor model combinations are available.

### EXAMPLE MODEL:

#### SUPERPROX® Product Series

SM9 5 2 A - 1 0 0 0 0 0 -

#### Power/Connection Type

- 0...12 to 24 VDC / cable style
- 5...12 to 24 VDC / connector style

#### Sensing Function

- 2...Dual level

#### Design Level

- A...Applies to all models

#### Sensing Range

- 1...51 mm to 1 m (2" to 39")
- 4...120 mm to 2 m (4.7" to 79")
- 7...120 mm to 1 m (4.7" to 39") - Required for ST option
- 8...203 mm to 8 m (8" to 26")

#### Level-Control Function

- 0...Pump-out latch
- 1...Pump-in latch
- 2...Dual setpoint
- 3...Dual alarm
- 4...Pump-in latch, with alarm
- 5...Pump-out latch, with alarm
- 6...Pump-in latch, with setpoint
- 7...Pump-out latch, with setpoint

#### Output Type

Level-control functions 0 and 1 (Pump in/out units without alarm or setpoint):

- 0...Normally open (N.O.) - NPN & PNP
- 1...Normally closed (N.C.) - NPN & PNP
- 2...Complementary NPN outputs
- 3...Complementary PNP outputs

Level-control functions 2 and 3 (Dual alarm/dual setpoint units):

- 4...Normally open (N.O.) - NPN outputs
- 5...Normally closed (N.C.) - NPN outputs
- 6...Normally open (N.O.) - PNP outputs
- 7...Normally closed (N.C.) - PNP outputs

Level-control functions 4 through 7 (Pump units with alarm or setpoint):

- 4...N.O. control and alarm/setpoint - NPN outputs
- 5...N.C. control and alarm/setpoint - NPN outputs
- 6...N.O. control and alarm/setpoint - PNP outputs
- 7...N.C. control and alarm/setpoint - PNP outputs
- 8...N.O. control, N.C. alarm/setpoint - NPN outputs
- 9...N.C. control, N.O. alarm/setpoint - NPN outputs
- A...N.O. control, N.C. alarm/setpoint - PNP outputs
- B...N.C. control, N.O. alarm/setpoint - PNP outputs

#### Response Time

- 0...Standard: 150 ms (1 m) / 200 ms (2 m) / 1 s (8 m)
- 1...300 ms (1 m) / 400 ms (2 m)
- 2...1.000 s (1 m) / 1.500 s (2 m)
- 4...500 ms (1 m and 2 m)

#### Functionality

- 00...Standard default window:  $\pm 6.35$  mm (0.25"), 1 m and 2 m;  $\pm 63.5$  mm (2.50"), 8 m
- 02...Default window,  $\pm 6.35$  mm (0.25"), 1 m and 2 m;  $\pm 63.5$  mm (2.50"), 8 m; outputs on on loss-of-echo
- 04...Default window,  $\pm 9.52$  mm (0.375"), 1 m and 2 m; outputs off on loss-of-echo

#### Options

- ...No designator indicates no options
- ST...Stainless transducer (available in stainless steel housing and 120 mm to 1 m models only)
- LE...No change in output on loss of echo
- FS...Fluorosilicone transducer face (1 m models only)
- AD...Limits push-button disabled

#### Housing Types

- ...No designator indicates standard ULTEM® plastic
- S...SS303 stainless steel (1 and 2 m models only)

NOTE: Contact the factory for DeviceNet communications capability  
 \* ULTEM® is a registered trademark of The General Electric Company.

until the level moves back closer than the near limit to stop the pumping process.

### **Pump-out Latch**

When the level moves farther than the far limit, the sensor level control output switches state and latches, stopping pump-out process. The sensor level control output does not change state until the level moves back closer than the near limit to restart the pumping process.

### **Dual Setpoint**

Two sensor outputs are used to enable this control function. One output operates independently with the near setpoint limit while the other operates independently with the far setpoint limit. The near setpoint limit output switches state when the level moves closer than the near setpoint limit and does not switch back until the level moves farther than the near setpoint limit.

The far setpoint limit output switches state when the level moves closer than the far setpoint limit and does not switch back until the level moves farther than the far setpoint limit.

### **Dual Alarm**

Two sensor outputs are used to enable this control function. One output operates independently with the near alarm limit while the other operates independently with the far alarm limit. The near alarm limit output switches state when the level moves above (closer than) the near alarm limit and changes state when the level moves back below (farther than) the near alarm limit. The far setpoint limit output switches state when the level moves below (farther than) the far alarm limit and changes state when the level moves back above (closer than) the far alarm limit. As a fail-safe, the normally open (N.O.) dual alarm outputs are physically active when the level is between the alarm limits and physically inactive when in an alarm condition.

### **Pump Latch with Alarm/Setpoint**

This control function uses a combination of the above level control functions.

## **Setting the Window Limits**

Located on the backside of the sensor, the SETUP push-button is used to set the near and far window limits within which the level sensing is to take place. Before

the limits are set, the sensor must be properly aligned with the object to be detected.

To set the window limits, depress the SETUP push-button (the multicolor LED rapidly flashes amber to indicate the push-button is being pressed) until the multicolor LED flashes green in about 3 seconds, and then release the SETUP push-button. The multicolor LED continues flashing green indicating the sensor is waiting for the first window limit. Align a flat object parallel to the sensor face at the desired distance position for either the near or far window limit, and press the SETUP push-button once. Upon release of the SETUP push-button, the multicolor LED flashes amber indicating the first window limit is set and the sensor is waiting for the second window limit. Align a flat object parallel to the sensor face at the desired position for the second window limit and press the SETUP push-button once. Upon release of the SETUP push-button, the multicolor LED turns to the color that indicates where the object is located. The sensor has no time-out for setting limits.

For sensor models with a control output and either an alarm or setpoint output, the alarm or setpoint limit is set after the window limits are set. With these models, after the SETUP push-button is pressed for the second window limit and released, the multicolor LED flashes amber/green indicating the second window limit is set and the sensor is waiting for either the alarm or setpoint limit. Align a flat object parallel to the sensor face at the desired position for either the alarm or setpoint limit and press the SETUP push-button once. Upon release of the SETUP push-button, the multicolor LED turns to the color that indicates where the object is located.

While the SETUP push-button is depressed, the multicolor LED turns amber to indicate the sensor detects the object. If the sensor does not detect the object, the multicolor LED is red while the SETUP push-button is depressed, and flashes 2 seconds when the SETUP push-button is released. After flashing red 2 seconds, the sensor requests that window limit again by flashing green for the first window limit or flashing amber for the second window limit.

A special feature of these sensors allows the user to set an automatic default window of fixed size anywhere within the sensing range. For the 1 and

2 meter range models, the standard default window is 12.7 mm (0.50"). It is 127 mm (5.0") for the 8 meter range models. Other default window sizes are available for all the models upon request. To easily set the default window, while the multicolor LED is flashing green, align a flat object parallel to the sensor face at the center of the desired window and press the SETUP push-button twice in succession without moving the object. An automatic default window limit will be set at a distance equal to half the default window in front of and behind the flat-object surface nearest the sensor. If, for example, the functionality of the 1 or 2 meter range sensor calls for the standard default window, the sensing window is set with limits 6.35 mm (0.25") in front of and behind the object's front surface.

For long distances or tall-tank applications, when use of the sensor's push-button is not practical, an optional, Model AC441A handheld configurator can be used to set or change the near and far window limits and display the object distance when the sensor is located up to 200 feet from the user. The Model AC441A cannot, however, be used to set the default window.

Once set, the window limits are saved in nonvolatile memory and thus are retained when power is removed from the sensor.

## **Loss of Echo Operation**

### **Output Off, On Loss of Echo**

Loss of echo occurs when the sensor does not receive echoes from an object or surface level within its sensing range for more than one second. When this occurs, the sensor's output automatically switches off. When the sensor again receives echoes, the output assumes the state relative to the dual-level control or dual-setpoint limits.

### **Output Holds, On Loss of Echo ("LE" Option)**

The LE suffix in the Model Reference Guide indicates an available option for users who do not prefer the standard response to loss of echo. With the LE option, when loss of echo occurs, there is no change in the output state of the sensor. When the sensor again receives echoes, the output assumes the state relative to the dual-level control or dual-setpoint limits.

# Sensor Operating Profiles

## Pump-in Latch

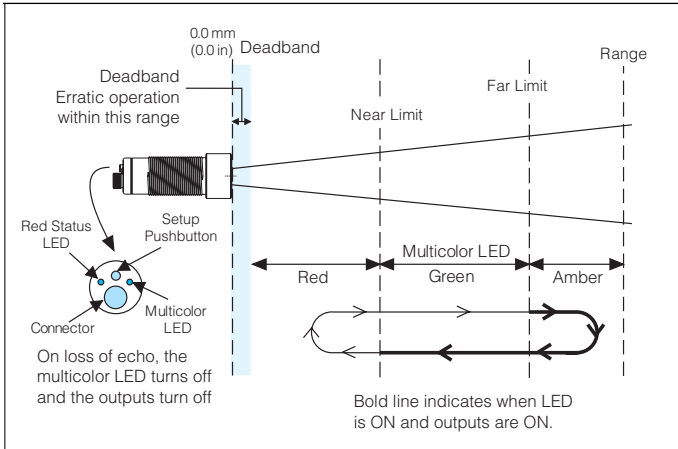

## Pump-out Latch

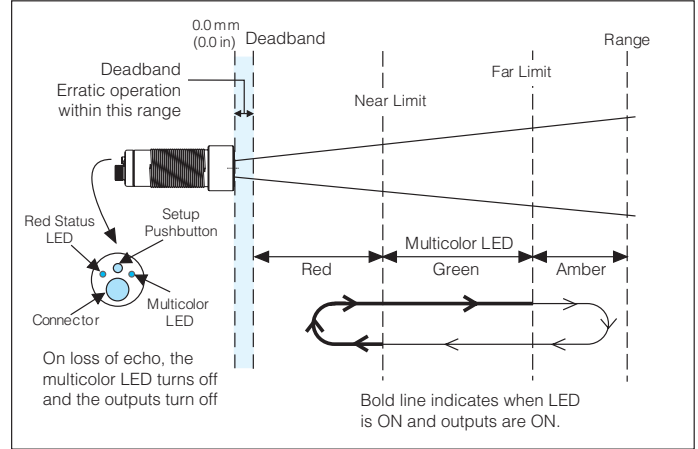

## Dual Setpoint

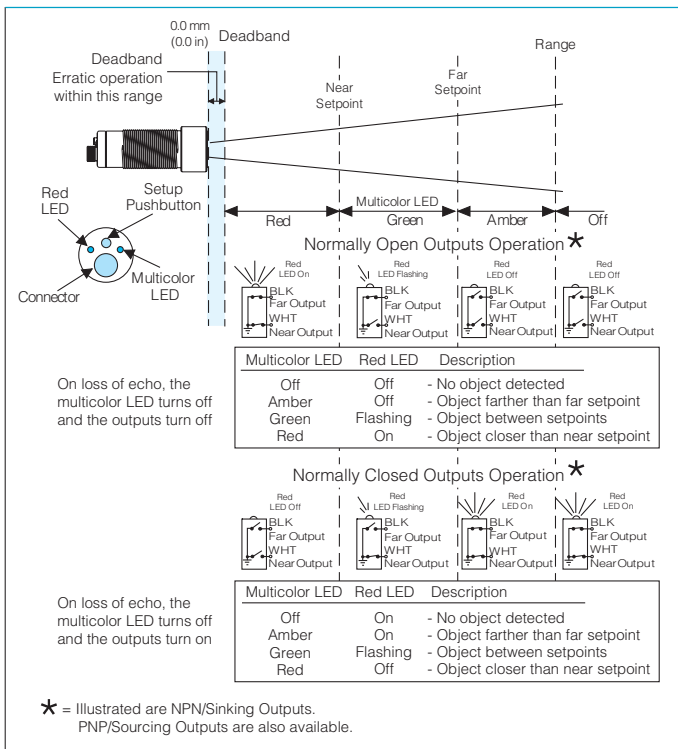

## Dual Alarm

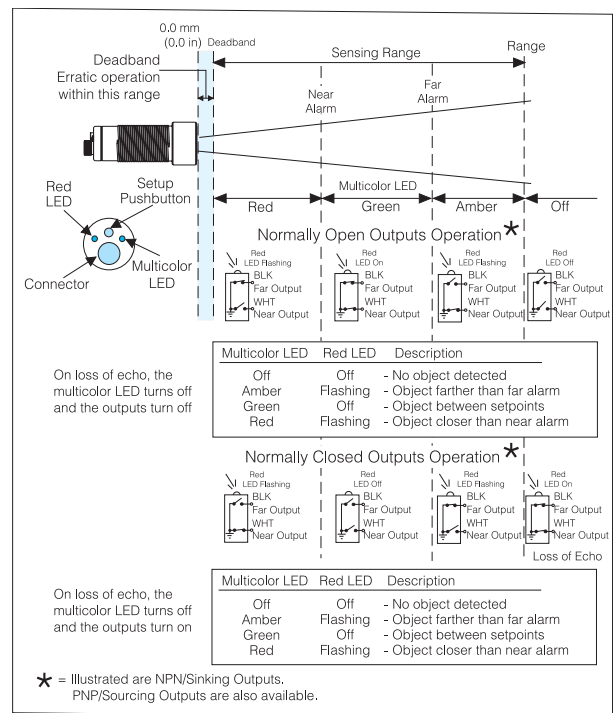

## NPNs Pump Latch with N.O. Setpoint

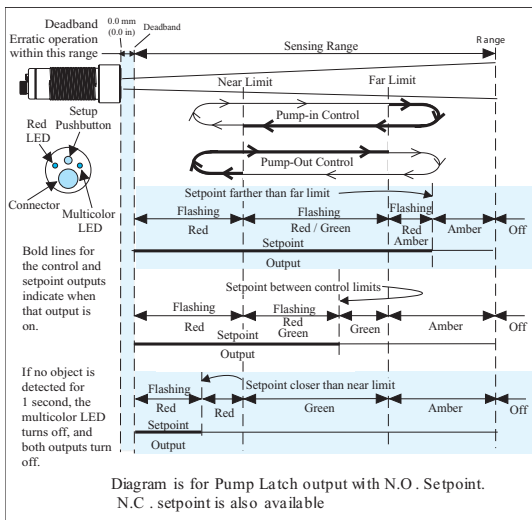

## NPNs Pump Latch with N.O. Alarm

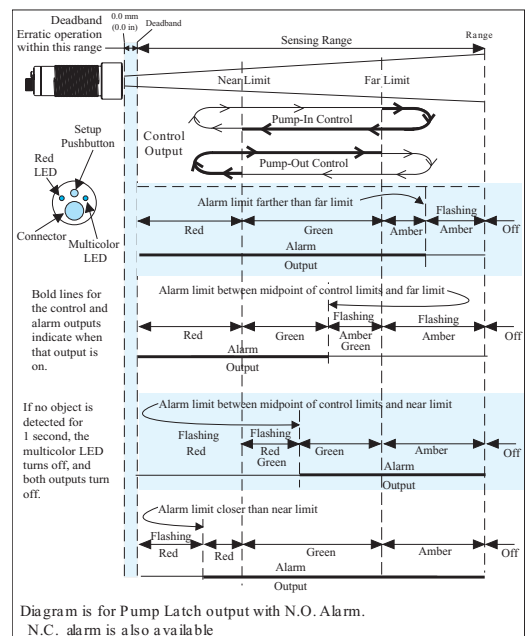

## Electrical Wiring

The sensor wires must be run in conduit free of any AC power or control wires.

### Cable Model Wire Assignments

### Connector Model Pin Assignments

#### Latch Outputs

Sinking/Sourcing - N.O./N.C. outputs

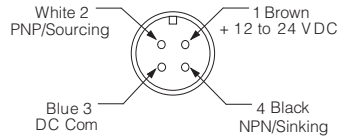
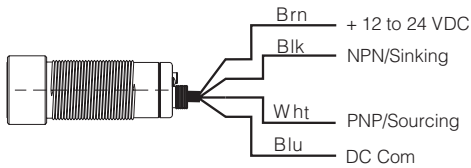

#### Complementary Sinking outputs

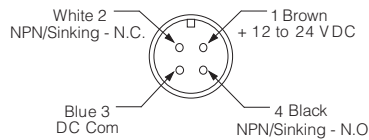
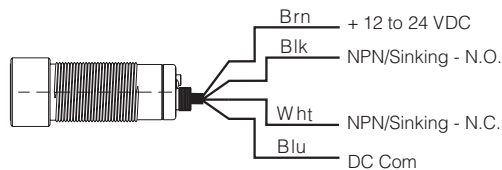

#### Complementary Sourcing outputs

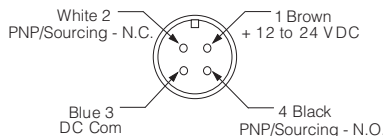
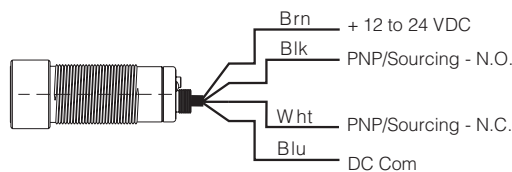

#### Dual Alarm Setpoint Outputs

NPN/Sinking - N.O./N.C., PNP/Sourcing - N.O./N.C.

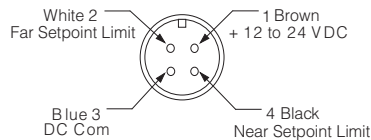
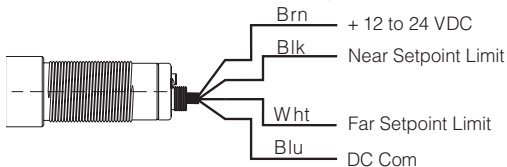

## Outputs

### Latch

NPN/Sinking and PNP/Sourcing

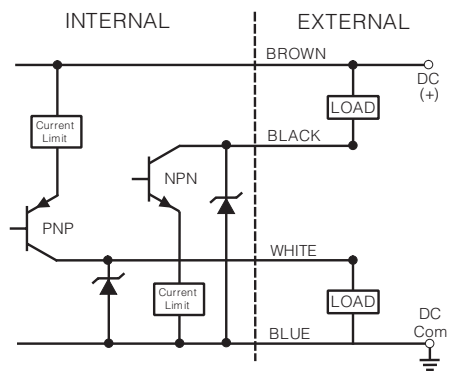

### Complementary NPN/Sinking

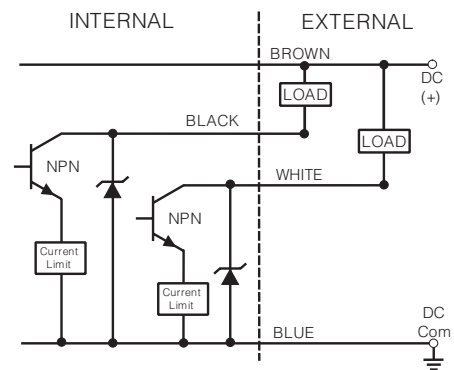

### Complementary PNP/Sourcing

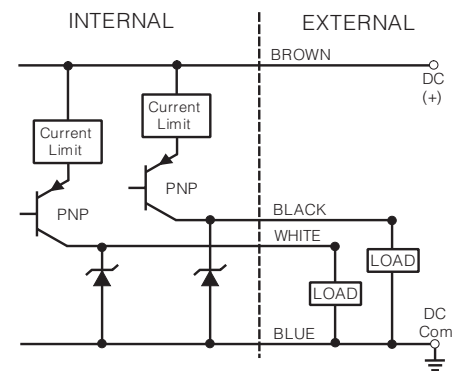

## Outputs

### Dual Alarm/Setpoint

Dual NPN/Sinking

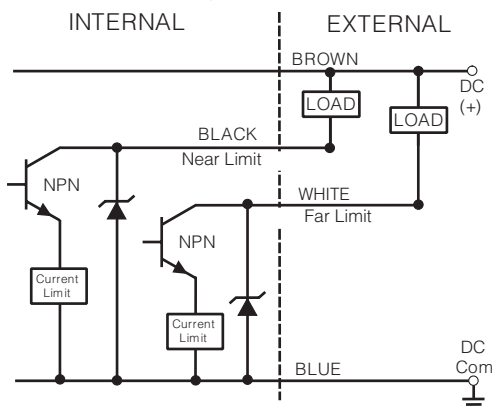

Dual PNP/Sourcing

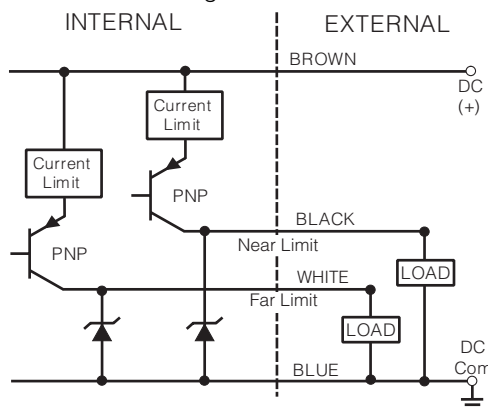

## Dimensions

### Cable Style

(ULTEM® plastic and SS303 stainless steel)  
SM902A-1, SM902A-4, SM902A-7STS

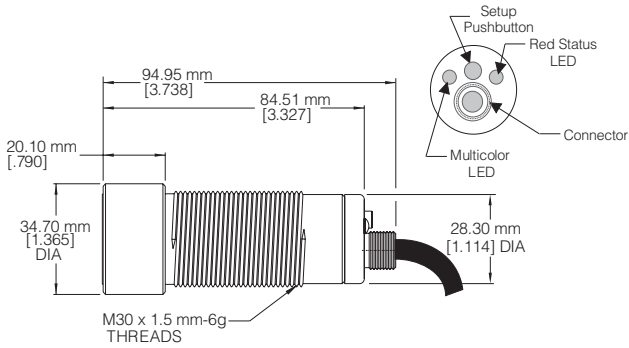

### Cable Style

(ULTEM® plastic and SS303 stainless steel)  
SM902A-8 long-range

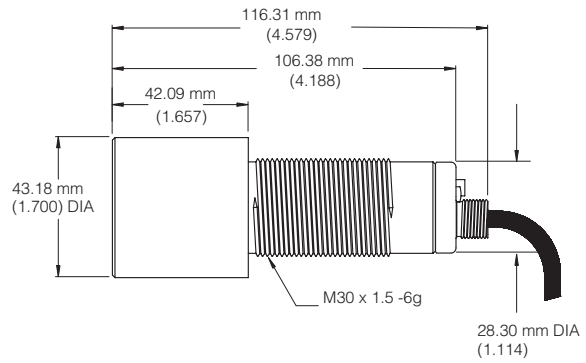

### Connector Style

(ULTEM® plastic and SS303 stainless steel)  
SM952A-1, SM952A-4, SM952A-7STS

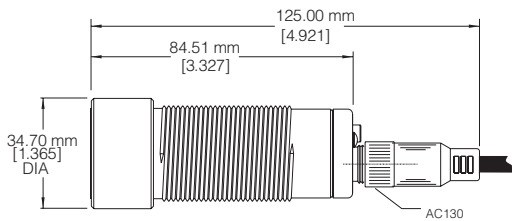

### Connector Style

(ULTEM® plastic and SS303 stainless steel)  
SM952A-8 long-range

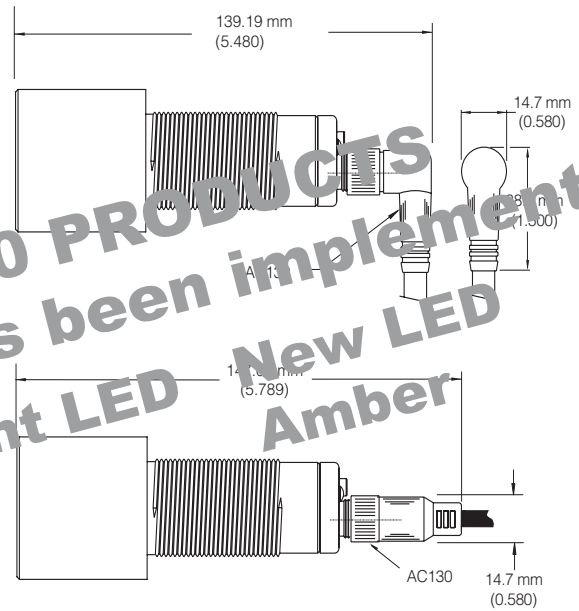
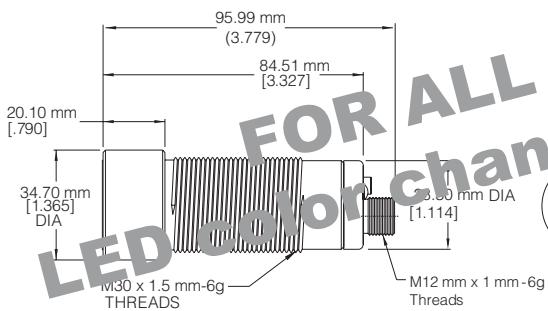
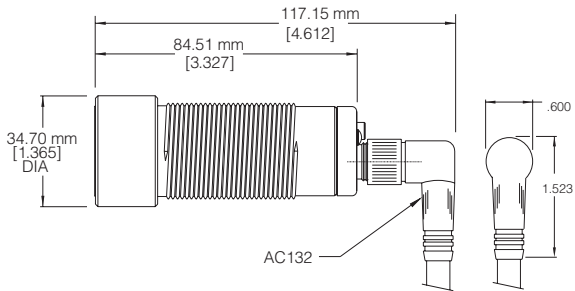
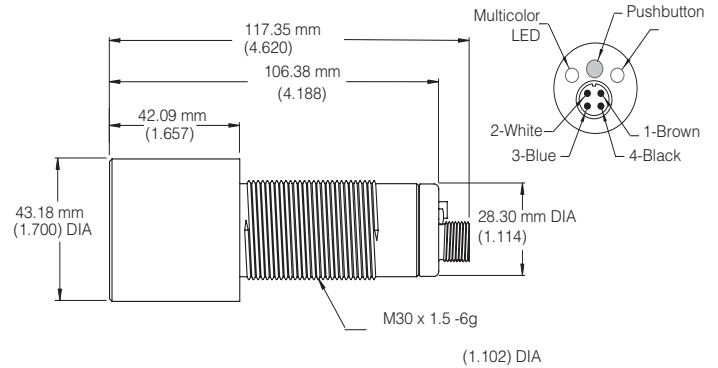

**FOR ALL SM900 PRODUCTS**  
LED color change has been implemented  
Current LED New LED  
Red Amber  
Output

**SUPERPROX® SM902  
SERIES**

## Accessories

**AC130** Straight, M12 micro, 4-conductor, connector/cable assembly, 5 m (16'), for 30 mm, barrel-style sensors

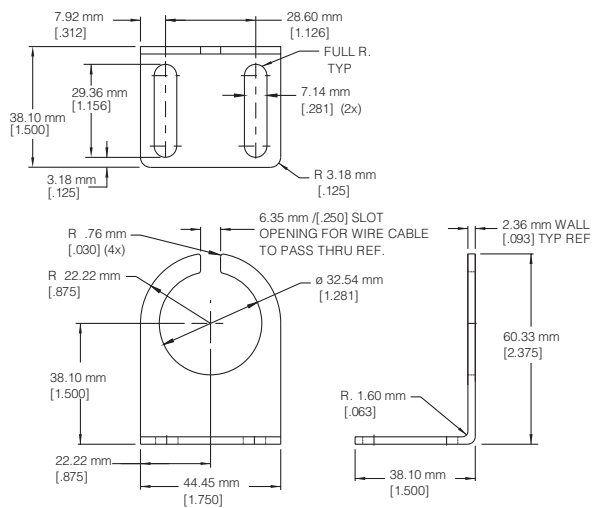
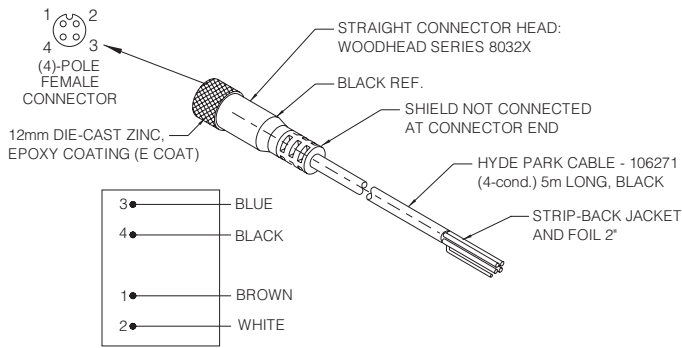

**AC132** Right-angle, M12 micro, 4-conductor, connector/cable assembly, 5 m (16'), for 30 mm, barrel-style sensors

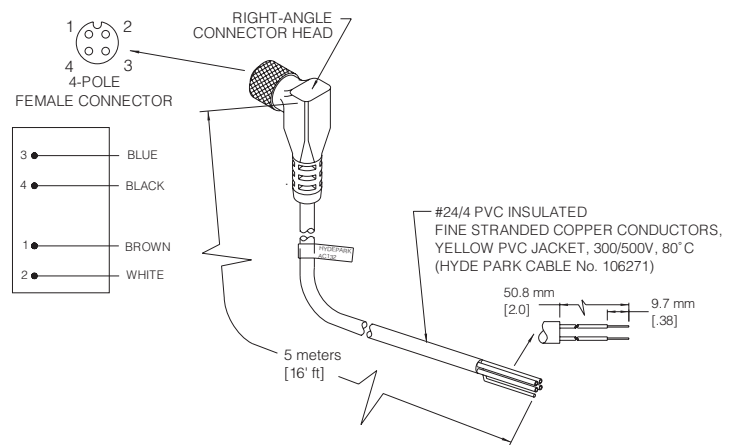

**AC233** Small, right-angle, stainless, mounting bracket for 30 mm, barrel-style sensors.

## General Specifications

Sensing [TA = 20° C (68° F)]

### 1 and 2 meter ranges

Model Sensing Ranges:

- 51 mm to 1 m (2.0" to 39")
- 120 mm to 1 m (4.7" to 39")\*\*
- 120 mm to 2 m (4.7" to 79")

Sonic Frequency: 200 kHz

Minimum-size Detection

(Model SM902A-1): 1.59 mm (0.0625")

diameter rod up to 635 mm (25") distance from sensor

Maximum Angular Deviation:

± 10° on 305 mm x 305 mm (12" x 12") flat target at a distance of 305 mm (12")

Sonic Cone Profile: See Beam Plots, Page 4-109

Limit Adjustment Resolution: 0.08 mm (0.003")

Repeatability: ± 0.8716 mm (0.03431") max.

Temperature Compensated

### Power Requirements

Supply Voltage:

12 to 24 VDC ± 10% excluding output load (regulated supply)

Current Consumption: 100 mA max., excluding load

Peak Inrush Current: 0.50 Amp.

Power Consumption: 1.2 W max., excluding load

### Outputs

Sinking Output (NPN):

Maximum on-state voltage @ 100 mA: 0.37 volt

Maximum load current: 100 mA

Maximum applied voltage: 35 VDC

Sourcing Output (PNP):

Maximum on-state voltage drop @

100 mA: 0.50 volt

Maximum load current: 100 mA

### Response Time - Standard

150 ms on/off (1 m range models)

200 ms on/off (2 m range models)

Other response times are available.

### Indicators

Multicolored (Amber, Red, Green) LED:

Indicates limits setup and operational modes.

Red LED:

Visual indicator for sensor output: illuminated when output is in an active (on) state.

### Connection Options

Cable Style:

24 AWG, foil shield, lead-free PVC jacketed,

4-conductor, 3 meters (10') long, standard

Connector Style:

12 mm, 4 pole, male

### Protection

Power Supply: current-limited over-voltage, ESD, reverse polarity

Outputs: current-limited over-voltage, ESD, over-current

**NOTE:** This sensor is NOT RATED EXPLOSION PROOF.

### Environmental

Operating Temperature Range:

0° to 50°C (32° to 122°F) for

silicone-faced models

-20° to 50°C (-4° to 122°F) for

stainless steel-faced models

Storage Temperature Range:

-10° to 80°C (14° to 176°F) for

silicone-faced models

-50° to 80°C (-58° to 176°F) for

stainless steel-faced models

Operating Humidity: 100%

Protection Ratings: NEMA 4X, IP67

Chemical Resistance: Unaffected by most acids, bases, and oils. Fluorosilicone and stainless steel-faced transducers available for severe, corrosive-type environments.

## Construction

### Dimensions:

Cable Model: 30 mm (1.181") dia. x 1.5 mm-6g threaded housing x 94.95 mm (3.738") long, including 34.70 mm (1.365") dia. x 20.10 mm (0.790") long sensing head

Connector Model: 30 mm (1.181") dia x 1.5 mm-6g threaded housing x 95.99 mm (3.779") long; 117.15 mm (4.612") long, including AC132 right-angle, M12 micro, connector/cable assembly; 125 mm (4.921") long, including AC130 straight, M12 micro, connector/cable assembly; sensing head dimension same as cable model.

Housing: Epoxy encapsulated to resist shock and vibration

Case: ULTEM® plastic (FDA Approved) or SS303 stainless steel

Transducer Face: Silicone rubber - gray SS304 stainless steel, 0.051 mm (0.002") thick\*\*

Sensor Cables: Lead-free, black PVC jacketed

## 8 meter, long range

### Model Sensing Range:

203 mm to 8 m (8.0" to 26')

### Sonic Frequency: 75 KHz

### Minimum-size Detection (Model SM902A-8):

50.8 mm (2.0") diameter rod up to 4572 mm (15') distance from the sensor

### Maximum Angular Deviation:

± 10° on a large flat surface at a distance of 6.096 m (20')

± 5° on a large flat surface at a distance of 8 m (26')

### Sonic Cone Profile: See Beam Plots, Page 4-109

### Limit Adjustment Resolution:

0.254 mm (0.01")

### Repeatability: ± 2.54 mm (0.10") max.

### Temperature Compensated

## Power Requirements

### Supply Voltage:

12 to 24 VDC ± 10% excluding output load (regulated supply)

### Current Consumption: 100 mA max., excluding load

### Peak Inrush Current: 0.50 Amp.

### Power Consumption: 1.2 W max., excluding load

## Outputs

### Sinking Output (NPN):

Maximum on-state voltage @ 100 mA: 0.37 volt

Maximum load current: 100 mA

Maximum applied voltage: 35 VDC

### Sourcing Output (PNP):

Maximum on-state voltage drop @ 100 mA: 0.50 volt

Maximum load current: 100 mA

## Response Time - Standard

1 s on/off

Other response times are available.

## Indicators

### Multicolored (Amber, Red, Green) LED:

Indicates limits setup and operational modes.

### Red LED:

Visual indicator for sensor output; illuminated when output is in an active (on) state.

## Connection Options

### Cable Style:

24 AWG, foil shield, lead-free PVC jacketed, 4-conductor, 3 meters (10') long, standard

### Connector Style:

12 mm, 4 pole, male

## Protection

Power Supply: current-limited over-voltage, ESD, reverse polarity

Outputs: current-limited over-voltage, ESD, over-current

**NOTE:** This sensor is NOT RATED EXPLOSION PROOF.

## Environmental

### Operating Temperature Range:

-20° to 60°C (-4° to 140°F)

### Storage Temperature Range:

-40° to 100°C (-40° to 212°F)

### Operating Humidity: 100%

### Protection Ratings: NEMA 4X, IP67

Chemical Resistance: Unaffected by most acids, bases, and oils.

## Construction

### Dimensions:

Cable Model: 30 mm (1.181") dia. x 1.5 mm-6g threaded housing x 116.31 mm (4.579") mm long, including 43.18 mm (1.70") dia. x 42.09 mm (1.657") long sensing head

Connector Model: 30 mm (1.181") dia x

1.5 mm-6g threaded housing x 117.35 mm (4.62") long; 139.19 mm (5.48") long, including AC132 right-angle, connector/cable assembly; 147.04 mm (5.789") long, including AC130 straight, connector/cable assembly; sensing head dimension same as cable model.

Housing: Epoxy encapsulated to resist shock and vibration

Case: ULTEM® plastic (FDA Approved)

Transducer Face: Epoxy - white

Sensor Cables: Lead-free, black PVC jacketed

## Agency Approvals

### CE Mark: CE conformity is declared to:

EN63126: 1997 (annex A, industrial) including amendment A1:1998. EN55011 group 1 Class A.

*Declaration of Conformity available upon request.*

\* ULTEM® is a registered trademark of The General Electric Co.

\*\* Available only in the stainless steel-faced, 1 m range models

## Accessories

**Model AC130**, Straight, M12 micro, 4-conductor, connector/cable assembly, 5 m (16')

**Model AC132**, Right-angle, M12 micro, 4-conductor, connector/cable assembly, 5 m (16')

**Model AC233**, Small, right-angle, stainless, mounting bracket

**Model AC250-n**, Tank sensor mounting reducer, available with four different outside diameters; used with all SUPERPROX® SM900 family sensors. n = 1 (1 1/4" NPT); 2 (2" NPT); 3 (3" NPT); 4 (4" NPT)

**Model AC251-n**, Tank sensor mounting flange, available with three different pipe thread diameters, furnished with matching AC250 Tank sensor mounting reducer; used with all SUPERPROX® SM900 family sensors. n = 2 (2" NPT); 3 (3" NPT); 4 (4" NPT)

**Model AC441A**, Handheld configurator

See Page 7-1 for accessory photos.

# Selection Chart

## SM902 Series Level with Analog Output

Model No.	12/24 VDC Power/Version		Connection Style				Sensing Range				Output Mode				Materials				Output Type	Special Features				
	Cable	Connector	51 mm - 1 m, 2" - 39"	120 mm - 2 m, 4.7' - 79"	120 mm - 1 m, 4.7' - 39"	203 mm - 8 m, 8" - 26'	Pump-out latch	Pump-in latch	Dual Setpoint	Dual alarm	Pump-in latch, with alarm	Pump-out latch, with alarm	Pump-in latch, with set point	Pump-out latch, with set point	Silicone	Stainless	Fluorosilicone	Epoxy		30 mm ULTEM®	30 mm stainless	Response Time	Default window	Loss of Echo Hold
SM902A-100000	■	■	■				■								■				■		N.O. NPN & PNP	150 ms	±0.25"	
SM902A-100000LES	■	■	■					■							■				■		N.O. NPN & PNP	150 ms	±0.25"	■
SM902A-110000LE	■	■	■						■						■				■		N.O. NPN & PNP	150 ms	±0.25"	■
SM902A-112000	■	■	■							■					■				■		Complementary NPN Outputs	150 ms	±0.25"	
SM902A-124000	■	■	■								■				■				■		N.O. NPN Outputs	150 ms	±0.25"	
SM902A-126000	■	■	■									■			■				■		N.O. PNP Outputs	150 ms	±0.25"	
SM902A-144100LE	■	■	■										■		■				■		N.O. Control & Alarm - NPN Outputs	300 ms	±0.25"	■
SM902A-168000	■	■	■											■	■				■		N.O. Control & N.C. Setpoint-NPN Outputs	150 ms	±0.25"	
SM902A-400000	■	■	■												■				■		N.O. NPN & PNP	200 ms	±0.25"	
SM902A-424000	■	■	■												■				■		N.O. NPN Outputs	200 ms	±0.25"	
SM902A-424000LES	■	■	■												■				■		N.O. NPN Outputs	200 ms	±0.25"	■
SM902A-435001	■	■	■												■				■		N.C. NPN Outputs	200 ms	±0.25"	
SM902A-444000LE	■	■	■												■				■		N.O. Control & Alarm - NPN Outputs	200 ms	±0.25"	■
SM902A-700000STS	■	■	■													■			■		N.O. NPN & PNP	150 ms	±0.25"	
SM902A-735000LESTS	■	■	■												■				■		N.C. NPN Outputs	150 ms	±0.25"	■
SM902A-824000	■	■	■															■	■		N.O. NPN Outputs	1.000 s	±2.50"	
SM952A-100000	■	■	■												■				■		N.O. NPN & PNP	150 ms	±0.25"	
SM952A-100000S	■	■	■												■				■		N.O. NPN & PNP	150 ms	±0.25"	
SM952A-100100LE	■	■	■												■				■		N.O. NPN & PNP	300 ms	±0.25"	■
SM952A-110000	■	■	■												■				■		N.O. NPN & PNP	150 ms	±0.25"	
SM952A-110000LE	■	■	■												■				■		N.O. NPN & PNP	150 ms	±0.25"	■
SM952A-110000LES	■	■	■												■				■		N.O. NPN & PNP	150 ms	±0.25"	■
SM952A-110000S	■	■	■												■				■		N.O. NPN & PNP	150 ms	±0.25"	
SM952A-110002	■	■	■												■				■		N.O. NPN & PNP	150 ms	±0.25"	
SM952A-110200	■	■	■												■				■		N.O. NPN & PNP	1.000 s	±0.25"	
SM952A-110200FS	■	■	■												■				■		N.O. NPN & PNP	1.000 s	±0.25"	
SM952A-110200LES	■	■	■												■				■		N.O. NPN & PNP	1.000 s	±0.25"	■
SM952A-112200	■	■	■												■				■		Complementary NPN Outputs	1.000 s	±0.25"	
SM952A-113100S	■	■	■												■				■		Complementary NPN Outputs	300 ms	±0.25"	
SM952A-124000	■	■	■												■				■		N.O. NPN Outputs	150 ms	±0.25"	
SM952A-124000LE	■	■	■												■				■		N.O. NPN Outputs	150 ms	±0.25"	■
SM952A-124000S	■	■	■												■				■		N.O. NPN Outputs	150 ms	±0.25"	
SM952A-124100LE	■	■	■												■				■		N.O. NPN Outputs	300 ms	±0.25"	■
SM952A-125000	■	■	■												■				■		N.C. NPN Outputs	150 ms	±0.25"	
SM952A-126000	■	■	■												■				■		N.O. PNP Outputs	150 ms	±0.25"	
SM952A-126000LES	■	■	■												■				■		N.O. PNP Outputs	150 ms	±0.25"	■
SM952A-127000	■	■	■												■				■		N.C. PNP Outputs	150 ms	±0.25"	
SM952A-134000	■	■	■												■				■		N.O. NPN Outputs	150 ms	±0.25"	
SM952A-136100LES	■	■	■												■				■		N.O. PNP Outputs	300 ms	±0.25"	■
SM952A-164000	■	■	■												■				■		N.O. Control & N.C. Setpoint-NPN Outputs	150 ms	±0.25"	
SM952A-400000	■	■	■												■				■		N.O. NPN & PNP	200 ms	±0.25"	
SM952A-410000	■	■	■												■				■		N.O. NPN & PNP	200 ms	±0.25"	
SM952A-410100LES	■	■	■												■				■		N.O. NPN & PNP	400 ms	±0.25"	■
SM952A-413000	■	■	■												■				■		Complementary NPN Outputs	200 ms	±0.25"	
SM952A-424000	■	■	■												■				■		N.O. NPN Outputs	200 ms	±0.25"	
SM952A-426000	■	■	■												■				■		N.O. PNP Outputs	200 ms	±0.25"	
SM952A-426000S	■	■	■												■				■		N.O. PNP Outputs	200 ms	±0.25"	
SM952A-426100	■	■	■												■				■		N.O. PNP Outputs	400 ms	±0.25"	
SM952A-434000	■	■	■												■				■		N.O. NPN Outputs	200 ms	±0.25"	
SM952A-437000LE	■	■	■												■				■		N.C. PNP Outputs	200 ms	±0.25"	■
SM952A-456000	■	■	■												■				■		N.O. Control & Alarm - PNP Outputs	200 ms	±0.25"	
SM952A-710000STS	■	■	■												■				■		N.O. NPN & PNP	150 ms	±0.25"	
SM952A-810000	■	■	■												■				■		N.O. NPN & PNP	1.000 s	±2.50"	

All possible sensor configurations are not listed here.



## SUPERPROX® Ultrasonic Analog Output Sensors

### Up to 8 Meter Span Measure- ment & Level Control

- Sensing spans of 1 m (39"), 2 m (79"), and 8 m (26')
- Easy push-button setup or optional hand-held, setup/display accessory available for all
- Either 4 to 20 mA or 0 to 10VDC analog output; either direct or inverse proportional outputs
- Epoxy sealed in tough ULTEM® plastic or stainless steel housing
- Resistant to caustic materials and harsh environments
- Field programmable capability
- DeviceNet capability
- CE certified



DeviceNet™

### Control levels and measure distances over spans of up to 8 meters (26 feet) with broad functionality and 30 mm mounting convenience

In vast contrast to other self-contained analog sensors, this new and smaller 30 mm, SUPERPROX® Model SM906 sensor series offers mounting convenience, broad functionality, and a selection of three analog sensing spans encompassing a few inches from the sensor to as far away as 26 feet. Depending on the model selected and the distance or level of the material being measured or controlled, the sensors offer analog spans of 1 m (39"), 2 m (79"), and a long span of 8 m (26'). The capability is enhanced further with the shortest deadbands in the sensing industry of 51 mm (2"), 120 mm (4.7"), and 203 mm (8"), respectively.

As shown in the Model Reference Guide, the SM906 series of ultrasonic analog sensors gives the user a wide selection of factory-configurable functionality

to maximize the sensor's efficiency in specific analog sensing applications. In addition to the analog sensing span, the user may select a 0 to 10 VDC or 4 to 20 mA output that is either directly or inversely proportional, output state for loss of echo and power up, and response time. Also, a broad selection of sensing functionality configurations, with foreground and/or background suppression, makes possible optimum sensing discrimination. This includes, for example, the capability of monitoring levels in a tank while ignoring the paddles on the tank agitator.

The 30 mm housing, 60% smaller than other analog sensors with equal functionality, provides a package for the SM906 that is easily installed, without positioning limitations, in covers and other hard-to-mount areas. The models in this series are equipped with a push-button to set the sensors' near and far span limits. When it is impractical to use the push-button for setting the long-range limits, an optional, hand-held, setup/display accessory is available. The two limits can be set for a span to either encompass the full range of the sensor or create a span as

small as desired for precise level or distance control. A typical example of precise level control is when the application calls for maintaining a constant fill level in a filler machine. In this example, the analog output provides a means of controlling the product flow into the filler as the filler speed changes. The analog output may provide a means for controlling the speed of other machinery as well as regulate the movement of control valve actuators. The analog output may also connect directly to programmable controller analog input modules for performing complex loop control or simple status (e.g., distance measuring) monitoring functions. All control limits are stored in nonvolatile memory and thus are retained if power is removed from the sensor.

Unlike other sensing technologies, these sensors are capable of detecting all materials, liquid, granular, and solid, regardless of color, shape, and composition, transparent or opaque, including powder, food products, grains, chemicals, pharmaceuticals, oils, plastics, and objects that change colors. The threaded housings are available in either ULTEM® plastic or SS303 stainless steel which are epoxy encapsulated to withstand shock and vibration. Both housings are sealed to withstand dusty, dirty, clean-in-place, noncondensing humidity, high-pressure washdown environments, and they are virtually unaffected by changing light conditions, colors, and noise. In meeting NEMA 4X and IP67 industry standards, the sensors resist most acids, bases, and oils, including most food products. All the sensors in this model series are CE certified.

### 1 meter and 2 meter span models

For purpose of definition, the standard 1 meter span models are identified in the Model Reference Guide as the Model SM906A-1 and SM956A-1 series sensors and the 2 meter-span models are identified as the Model SM906A-4 and SM956A-4 series sensors. Respectively, these models provide for analog output sensing from 50.8 mm to 1 m (2" to 39") and 120 mm to 2 m (4.7" to 79"). The 96 mm (3.78") length of the connector model, excluding the connector/cable assembly, adds to the sensor's installation convenience. Operating on a sonic frequency of 200 kHz, these sensors have a standard response time of 25 ms and 35 ms for the 1 and 2 meter span models, respectively, with others available as shown in the Model Reference Guide. The FDA approved silicone rubber transducer,

while used to couple the ultrasonic energy to the air, is also resistant to most acids, bases, oils, and food products.

Various functional choices plus the mounting convenience of a 30 mm housing combine to achieve reliability and cost effectiveness for these models in the detection of moving object positions in specific sensing applications. These include: monitoring and controlling levels of liquids and solid materials in bins and filler bowls, controlling container flow on mass conveyors, monitoring and controlling roll diameters and speeds, webs of paper and fabrics, extrusion widths, tension, dancer loops and valve positions, as well as the modulation of variable-speed motors, pumps and winding/unwinding equipment.

For 1 meter span, analog output sensing applications that require measurement and control capability in severe, corrosive-type environments, the Model SM906A-7STS and Model SM956A-7STS series models have an SS303 stainless steel housing and an SS304 stainless steel-faced transducer. With an analog sensing span of 120 mm to 1 m (4.7" to 39"), these sensors provide reliable operation in either the detection of certain chemicals and corrosive materials or where caustic cleaning solutions are used in washdowns of machinery and equipment in close proximity to the sensor. For out-of-doors, analog sensing applications, where cold weather is a factor, this corrosion-resistant model series provides reliable operation in temperatures as low as -10°C (-14°F).

### 8 meter, long-span models

The Model SM906A-8 and Model SM956A-8 series represents the only analog sensors on the market that offers the combination of shortest deadband, longest span, and smallest package. As indicated in the Model Reference Guide, these sensors measure and monitor the position and level of objects over a sensing span of just 203 mm (8") to 8 m (26'). With this shortest deadband, the need to position the sensor at great distances from the object, typical of most long-span sensors, is eliminated. At only 116.31 mm (4.579") in length for the cable-style model, a fraction of the size of other long-span sensors, these 30 mm diameter sensors are easily mounted in covers and other tight spaces in the plant. They operate on a sonic frequency of 75 kHz with a standard response time of 250 ms and a minimum response time of 150 ms. Other response times are available. An epoxy transducer face, in addition to

coupling the ultrasonic energy to the air, allows the sensor to perform in a wide range of harsh environments including those involving most acids, bases, and oils.

By virtue of the 75 kHz frequency, the sensor's wide, 20-degree beam is especially effective in sensing the tank or bin levels of various types of liquids, solids, and granules. This includes applications involving the blending of ingredients and the processing of food products and pharmaceuticals, as well as the treatment of water and sewage. For outdoor analog output applications, the sensors have temperature compensation for operation in temperatures ranging from -20° to 60°C (-4° to 140°F). In applications where high sound absorption conditions exist in the material being detected, (e.g., tiny plastic pellets), and either the 1 or 2 meter span model sensor becomes unreliable because of lost energy, the more powerful long-span SM906 can provide the solution when used in the shorter-span distances.

### Operation

The SUPERPROX® Model SM906 series is a self-contained, pulse-echo device that both transmits and receives sonic energy within the specified analog span. Operating on 15 to 24 VDC, these sensors use the latest ultrasonic sensing and microprocessor technology that allows the sensor to ignore all surrounding sonic interference and detect only the designated object.

During operation, the sensor monitors the distance to an object or level while generating a proportional analog output relative to the two analog span limits. When an object is within the analog span, the analog output value changes proportionally in relation to the analog span limits. For example, if the object is halfway between the analog span limits, the output is either 5 volts or 12 mA, depending on the output model selected. The output range adjusts to the size of the analog span and remains proportional regardless of where the limits are set for the analog span.

The sensors are equipped with a multicolor sensing status LED and a red output LED. The multicolor LED indicates where the level or target position is relative to the span limits. It is green when the object is between the analog span limits, red if closer than the near span limit, and amber if farther than the far span limit. The red LED indicates the relative value of the analog output and varies in intensity according to the

output. The higher the current or voltage output, the brighter the red LED.

As shown on this page, Hyde Park offers both direct and inverse proportional analog output models for continuous sensing applications.

### How does it work?

During setup and operation, these SM906 series ultrasonic sensors continually and accurately measure the elapsed time of every pulse echo reception between each pulse transmission. The transmitted pulse begins a time clock to register the elapsed times for the received pulse echoes. Given the elapsed time, the sensor software calculates the distance traveled out to the object or surface and back to the sensor, using the formula,  $D = Tv_s/2$ , where:  $D$  = distance from the sensor to the object;  $T$  = elapsed time between the pulse transmission and its echo receptions; and  $V_s$  = the velocity of sound, approximately 1100 feet per second.

During operation, the calculated distance ( $D$ ) between the sensor and the object is compared to the distances between the sensor and the analog span limits. These limits are shown in the illustration below as  $D_{wi}$  and  $D_{wo}$ . If  $D$  is within the analog span limits, according to the selected sensing functionality configuration, a proportional output value for  $D$ , relative to the analog span limits, is generated.

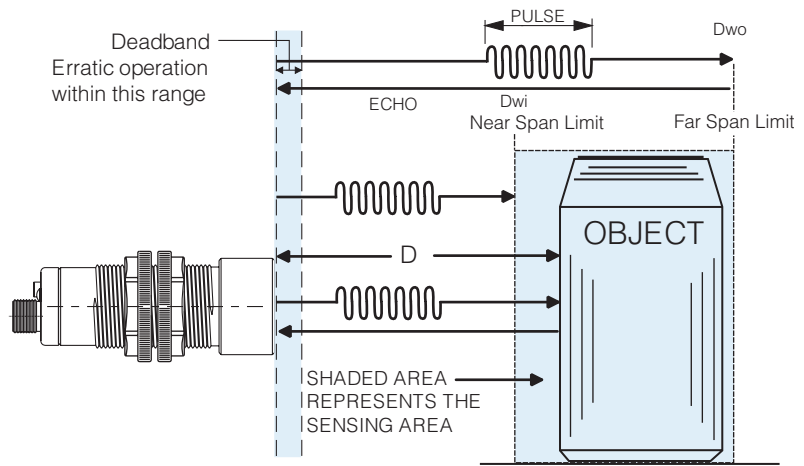

### Inverse Proportional Output

The analog 0 to 10 Volt or 4 to 20 mA signal value decreases as the object moves closer to the near span limit.

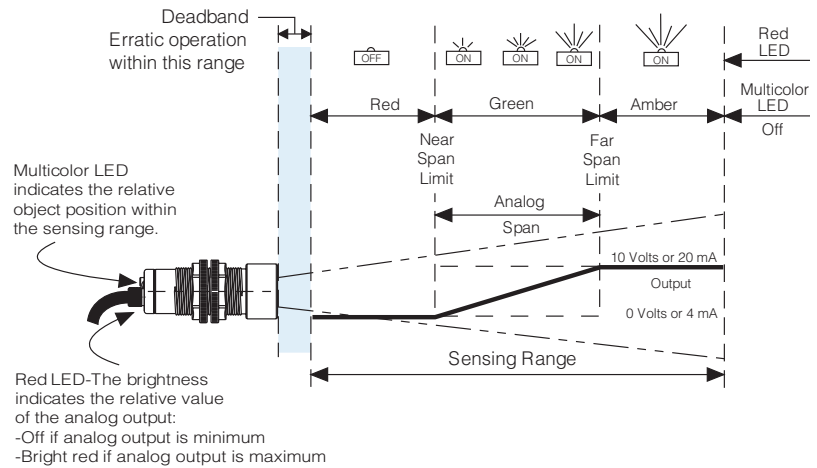

### Direct Proportional Output

The analog 10 to 0 Volt or 20 to 4 mA signal value increases as the object moves closer to the near span limit.

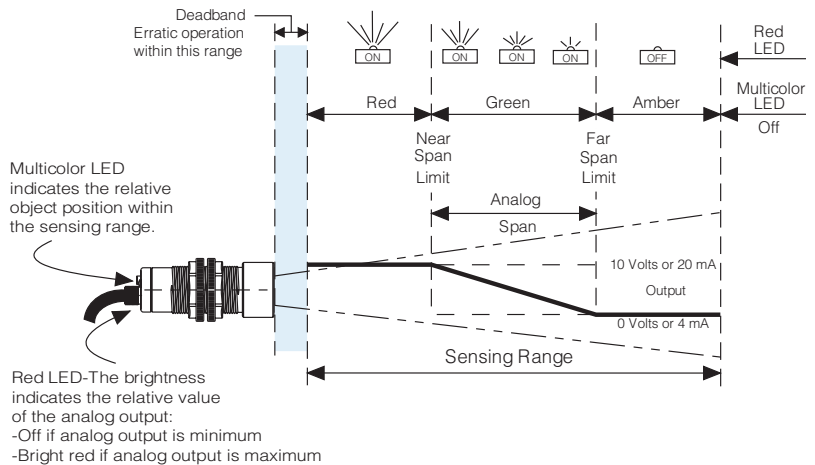

## Model Reference Guide - SM906 Series

Use the guide below to ensure the correct model number is specified for the application. Please note that not all sensor model combinations are available.

### EXAMPLE MODEL:

SM9 5 6 A - 1 0 0 0 00 -

#### SUPERPROX® Product Series

#### Power/Connection Type

0...15 to 24 VDC / cable style

5...15 to 24 VDC / connector style

#### Sensing Function

6...Analog

#### Design Level

A...Applies to all models

#### Analog Span

1...51 mm to 1 m (2 to 39")

4...120 mm to 2 m (4.7 to 79")

7...120 mm to 1 m (4.7 to 39") - Required for ST option

8...203 mm to 8 m (8" to 26')

#### Output Signal

0...Inverse 0 to 10 V

4...Inverse 0 to 5 V

8... Autoslope 0 to 10 V

1...Direct 0 to 10 V

5...Direct 0-5 V

9... Autoslope 4 to 20 mA

2...Inverse 4 to 20 mA

6...Inverse 0 to 20 mA

3...Direct 4 to 20 mA

7...Direct 0 to 20 mA

#### Output State for Loss of Echo and Power Up

0...Minimum

1...Maximum

2...Hold on loss of echo and minimum on power up

3...Hold on loss of echo and maximum on power up

#### Response Time

0...Standard: 25 ms (1 m) / 35 ms (2 m) / 250 ms (8 m)

1...Fast: 15 ms (1 m) / 20 ms (2 m) / 150 ms (8 m)

2...100 ms (1 m/2 m)

3...250 ms (1 m/2 m)

4...500 ms (1 m/2 m/8 m)

5...1.00 s (1 m/2 m/8 m)

6...2.50 s (1 m/2 m/8 m)

#### Functionality

00...Standard: No foreground or background suppression (background mode)

01...Foreground suppression only (object mode) ignore echoes before near limit

02...Foreground suppression only (background mode), process first echo, ignore if before near limit

03...Foreground and background suppression (background mode), process first echo, ignore if not within limits

#### Options

...No designator indicates no options

ST...Stainless transducer (available in stainless steel housing for 120 mm to 1 m models only)

FS...Fluorosilicone transducer face (1 m models only)

AD...Limits push-button disabled

#### Housing Types

...No designator indicates standard ULTEM® plastic housing

S...SS303 stainless steel (1 and 2 m models only)

\* ULTEM® is a registered trademark of The General Electric Company.

Field configurable and DeviceNet Model Reference Guides start on page 4-145.

## Sensing Functionality Configuration

There are four sensing functionality configurations available, through model selection, to provide a Model SM906 series sensor with optimum sensing discrimination. This means the sensor is capable of detecting objects at certain distances and ignoring objects at other distances. An example would be in the monitoring of a level in a tank while ignoring the paddles on the tank agitator which would be closer than the near span limit.

Each configuration employs a different algorithm to determine which echo returns are either accepted or ignored over the specified sensing range. Thus, these four configurations enable the sensor series to address a multitude of continuous-sensing, process-control applications.

Use the following four illustrations as a guide in selecting the functionality best suited for the sensing application.

### Configuration: "00" - Standard: No foreground or background suppression

With this configuration, the sensor processes only the first echo received from anywhere within the sensing span.

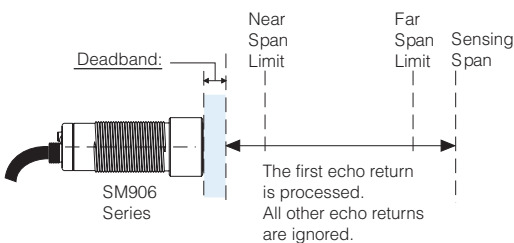

### Configuration: "01" - Foreground suppression only (object mode)

With this configuration, the sensor ignores echoes received from objects closer than the near span limit and processes only the first echo received from between the near span limit and the sensing range.

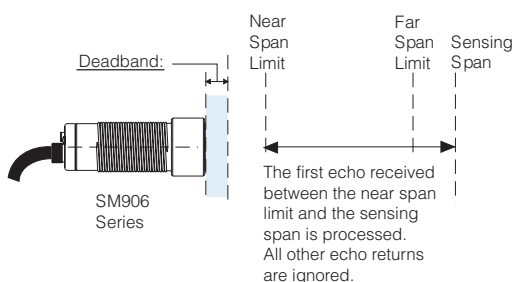

### Configuration: "02" - Foreground suppression only (background mode)

With this configuration, the sensor processes only the first echo received from an object. If the first processed echo from the object is closer than the near span limit, the echo is ignored and not processed. If the first processed echo from the object is between the near span limit and the sensing range, the echo is processed and the analog output value is updated.

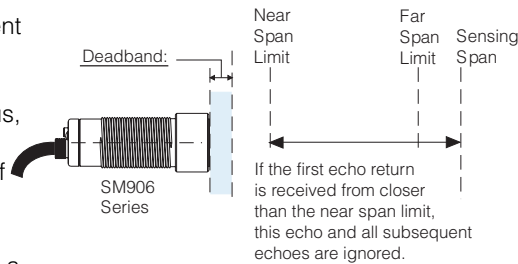

### Configuration: "03" - Foreground and background suppression (background mode)

With this configuration, the sensor processes only the first echo received from an object. If the echo is received from between the near and far span limits, the echo is accepted and the analog output value is updated. If the echo is received from closer than the near span limit or farther than the far span limit, the echo is ignored and the analog output value is not updated.

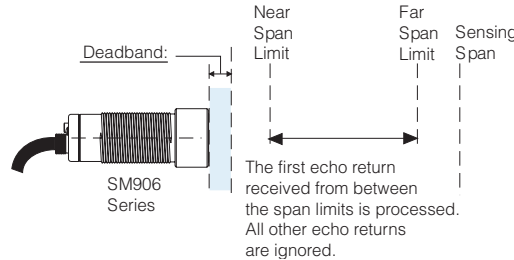

## Analog Output Response Function

The analog output value is derived from the sensor response time and the object distance from the sensor. The "standard" response for the one meter range sensing model is 25 ms and its analog output value is derived from the average of the last two echo returns. The "fast" response time for a one meter range sensing model is 15 ms and its analog output value is derived from the last echo return. For sensors with other response times, the analog output value reaches 95% of the final output value in the stated response time using an

exponential averaging function.

## Setting the Analog Span Limits

Located on the backside of the sensor, the SETUP push-button is used to set both the near and far span limits. Depress the SETUP push-button (the multicolor LED rapidly flashes amber to indicate the push-button is being pressed) until the multicolor LED flashes green in about 3 seconds, and then release the SETUP push-button. The multicolor LED continues flashing green indicating the sensor is waiting for the first span limit. Align a flat object parallel to the sensor face at the desired distance position for either (near or far) span limit, and press the SETUP push-button once. Upon release of the SETUP push-button, the multicolor LED flashes amber indicating the first span limit is set and the sensor is waiting for the second span limit. Align a flat object parallel to the sensor face at the desired position for the second span limit and press the SETUP push-button once. Upon release of the SETUP push-button, the multicolor LED turns to the color that indicates where the object is located. The sensor has no time-out for setting limits.

While the SETUP push-button is depressed, the multicolor LED turns amber to indicate the sensor detects the object. If the sensor does not detect the object, the multicolor LED is red while the SETUP push-button is depressed, and when the SETUP push-button is released, the multicolor LED flashes red for 2 seconds. After flashing red for 2 seconds, the sensor requests that span limit again by flashing green for the first span limit or flashing amber for the second span limit.

Once set, span limits are saved in nonvolatile memory and thus are retained when power is removed from the sensor.

## Output State for Loss of Echo Selections

As shown in the Model Reference Guide, four selections are available to address loss of echo conditions for specific applications.

### Selection "0" or "1" - Without Signal Hold on Loss of Echo

On power-up or when no echoes are detected for one second, for the 1 and 2 meter sensing span and 4 seconds for the 8 meter sensing span, the analog output will go to a minimum value for selection 0 or a maximum value for selection 1.

**Selection “2” or “3” - With Signal Hold on Loss of Echo**

If no echoes are received after power-up, the analog output value is a minimum when using selection 2 or a maximum when using selection 3. In addition, if echoes are not detected, the analog output value holds until echoes are once again received within the sensor’s range.

**Multicolor LED Operation**

- Red- object sensed closer than the near span limit.
- Green- object sensed at or between the near and far span limits.
- Amber- object sensed beyond the far span limit.
- Off- no object sensed within the full sensing range.

**Red LED Operation**

The red LED intensity varies directly with the magnitude or the analog output. The red LED is off when the output is at a minimum and full brightness when the output is at a maximum.

**Electrical Wiring**

The sensor wires must be run in one bundle of any AC power or control wires.

**Cable Model Wire Assignments**

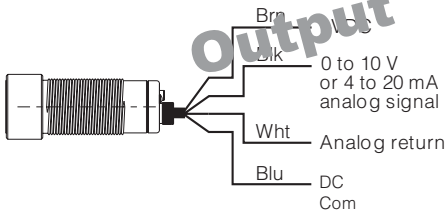

**Connector Model Pin Assignments**

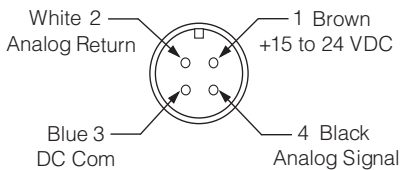

**Dimensions**

**Cable Style**

(ULTEM® plastic and stainless steel)  
SM906A-1, SM906A-4, SM906A-7STS

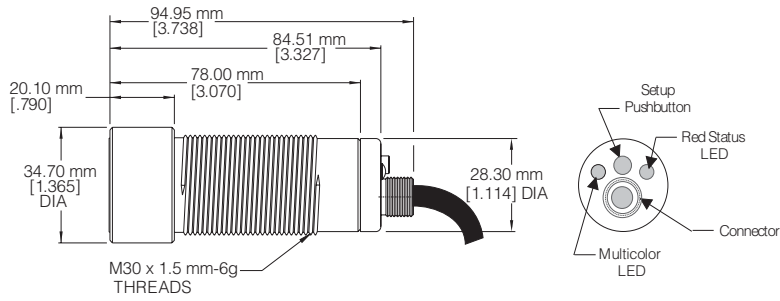

**Connector Style**

(ULTEM® plastic and Stainless Steel)  
SM956A-1, SM956A-4, SM956A-7STS

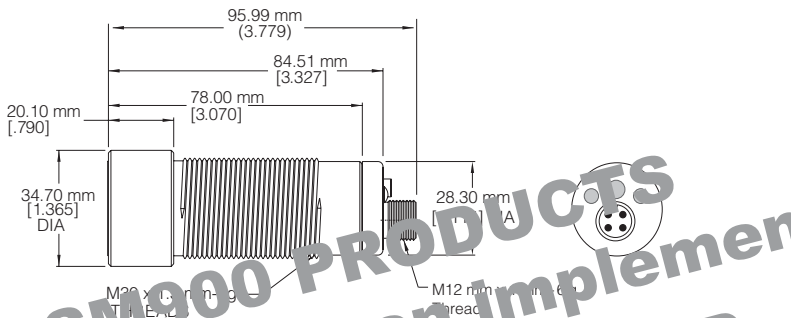

FOR ALL SM900 PRODUCTS  
LED color change has been implemented  
Current LED Amber  
Red

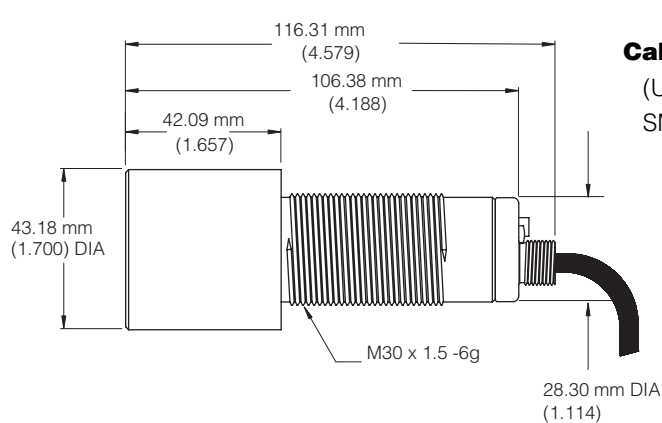
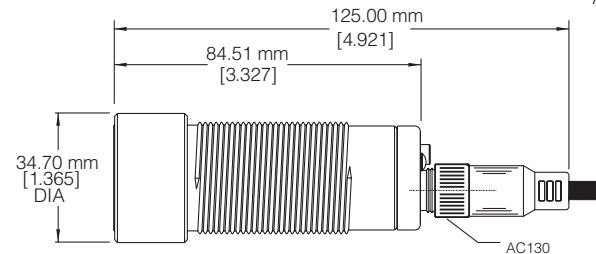
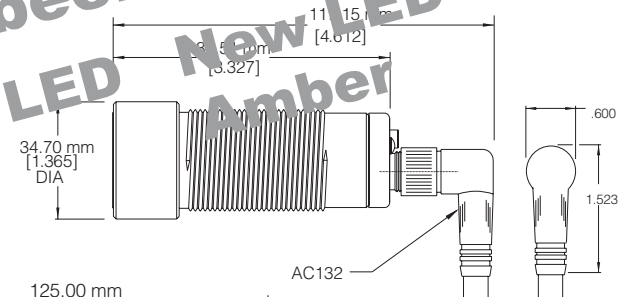

**Cable Style**

(ULTEM® plastic)  
SM906A-8 long-range

## Connector Style

(ULTEM® plastic)

SM956A-8 long-range

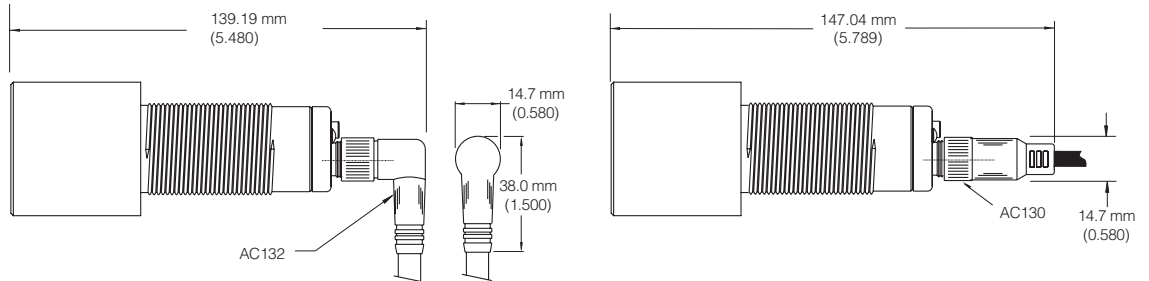
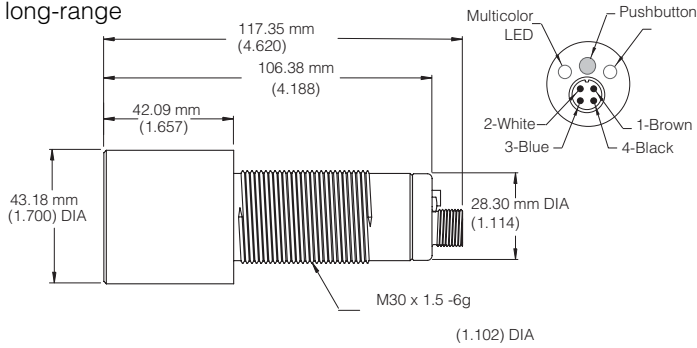

## Mounting Accessories

**AC130**, Straight, M12 micro, 4-conductor, connector/cable assembly, 5 m (16'), for 30 mm, barrel-style sensors

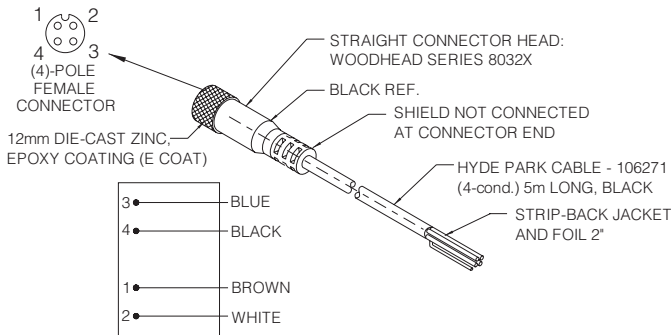

**AC233**, Small, right-angle, stainless mounting bracket for 30 mm, barrel-style sensors

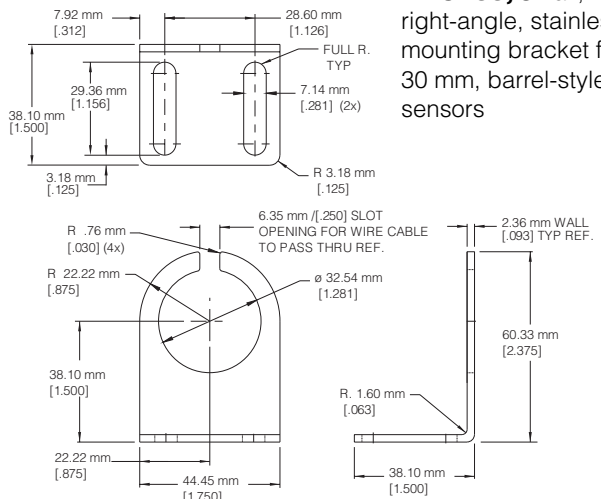

**AC132**, Right-angle, M12 micro, 4-conductor, connector/cable assembly, 5 m (16'), for 30 mm, barrel-style sensors

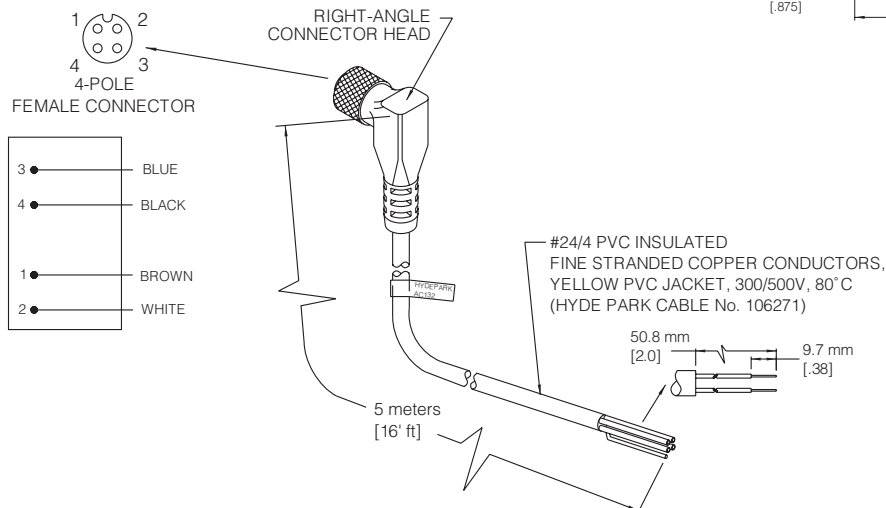

SUPERPROX® SM906 SERIES

## General Specifications

Sensing [TA = 20° C (68° F)]

### 1 and 2 meter ranges

Model Sensing Ranges:

- 51 mm to 1 m (2.0' to 39")
- 120 mm to 1 m (4.7 to 39")\*\*
- 120 mm to 2 m (4.7 to 79")

Sonic Frequency: 200 kHz

Minimum Object-size Detection:

- 1.59 mm (0.0625") diameter rod up to 635 mm (26") distance from sensor

Maximum Angular Deviation:

- ± 10° on 305 mm x 305 mm (12' x 12") flat target at a distance of 305 mm (12')

Sonic Cone Profile: See Beam Plots, Page 4-109

Limit Adjustment Resolution: 0.08 mm (0.003")

Repeatability: ± 0.8716 mm (0.03431") max.

Temperature Compensated

### Power Requirements

Supply Voltage

- 15 to 24 VDC @ 80 mA, excluding output load

Current Consumption: 80 mA max., excluding load

Peak Inrush Current: 0.75 Amp.

Power Consumption: 1.2 W max., excluding load

### Outputs

Output Range:

- 0 to 10 VDC or 4 to 20 mA, depending on model selected

Output Configuration:

- Inverse (0 to 10 VDC or 4 to 20 mA)
- Direct (10 to 0 VDC or 20 to 4 mA)

Voltage Output Slope: 33 mV/mm

- (0.833 V/inch) using a 305 mm (12") span

Minimum Load Resistance: 1 K Ohms

- (5 K Ohms recommended for best accuracy)

Current Output Slope: 52 µA/mm (1.33 mA/inch) using a 305 mm (12") span

Maximum Load Resistance: 500 Ohms

- (250 Ohms recommended for best accuracy)

### Analog Output Electrical Specifications

(Test conditions: 24 VDC, TA = 20° C, large flat target, still air, @ minimum span size of 304.8 mm or 12")

	current output <sup>1</sup>	voltage output <sup>2</sup>
Output Range	4-20 mA	0-10 V
Load Resistance (Ohms)	10 to 500	1 K to ∞
Resolution <sup>3</sup>	4.88 µA	2.44 mVDC
Accuracy (% of span) <sup>4</sup>	± 0.50	± 0.40
Linearity (% of span)	± 0.10	± 0.10
Temperature Dependence (% of span, °C)	± 0.006	± 0.004

<sup>1</sup>tested with 250 Ohm load

<sup>2</sup>tested with 1000 Ohm load; a low value is recommended to minimize noise pickup

<sup>3</sup>resolution = span/4096; Maximum: 0.23 mm (0.009") for 1 meter model, max. span 0.459 mm (0.018") for 2 meter model, max. span

<sup>4</sup>best accuracy may be limited to 0.794 mm (0.03125") due to wave-skip phenomena

### Response Times - Minimum, standard

15 ms on/off, 25 ms on/off (1 m range models)

20 ms on/off, 35 ms on/off (2 m range models)

Other response times are available.

### Indicators

Multicolored (Amber, Red, Green) LED:

- Indicates object position relative to the span limits

Red LED:

- Intensity increases as output signal increases.

### Connection Options

Cable Style:

- 24 AWG, foil shield, lead-free PVC jacketed, 4-conductor, 3 meters (10') long, standard

Connector Style:

- 12 mm, 4-pole, male

### Protection

Power Supply: current-limited over-voltage, ESD, reverse polarity

Outputs: current-limited over-voltage, ESD, over-current

**NOTE:** This sensor is NOT RATED EXPLOSION PROOF.

### Environmental

Operating Temperature Range:

- 0° to 50°C (32° to 122°F) for silicone-faced models

- 20° to 50°C (-4° to 122°F) for stainless steel-faced models

Storage Temperature Range:

- 40° to 100°C (-40° to 212°F) for silicone-faced models

- 50° to 80°C (-58° to 176°F) for stainless steel-faced models

Operating Humidity: 100%

Protection Ratings: NEMA 4X, IP67

Chemical Resistance: Unaffected by most acids, bases, and oils. Fluorosilicone and stainless steel-faced transducers available for severe, corrosive-type environments.

### Construction

Dimensions:

- Cable Model: 30 mm (1.181") dia. x 1.5 mm-6g threaded housing x 94.95 mm (3.738") mm long, including 34.70 mm (1.365") dia. x 20.10 mm (0.790") long sensing head

Connector Model: 30 mm (1.181") dia

- x 1.5mm-6g threaded housing x 95.99 mm (3.779") long; 117.15 mm (4.612") long, including AC 132 right-angle, M12 micro, connector/cable assembly; 125 mm (4.921") long, including AC130 straight, M12 micro, connector/cable assembly; sensing head dimension same as cable model.

Housing: Epoxy encapsulated to resist shock and vibration

Case: ULTEM®\* plastic or SS303 stainless steel

Transducer Face: Silicone rubber - gray SS304 stainless steel, 0.051 mm (0.002") thick\*\*

Sensor Cables: Lead-free, black PVC jacketed

### 8 meter, long range

Model Sensing Range:

- 203 mm to 8 m (8.0' to 26')

Sonic Frequency: 75 kHz

Minimum Object-size Detection:

- 50.8 mm (2.0") diameter rod up to 4572 mm (15') distance from the sensor

Maximum Angular Deviation:

- ± 10° on a large flat surface at a distance of 6.096 m (20')

- ± 5 on a large flat surface at a distance of 8 m (26') sonic cone profile: see beam plots, Page 4-109

Limit Adjustment Resolution: 0.254 mm (0.01")

Repeatability: ± 2.54 mm (0.10") max.

Temperature Compensated

### Power Requirements

Supply Voltage

- 15 to 24 VDC ± 10%, excluding output load, regulated supply

Current Consumption: 80 mA max., excluding load

Peak Inrush Current: 0.75 Amp.

Power Consumption: 1.2 W max., excluding load

### Outputs

Output Range:

- 0 to 10 VDC or 4 to 20 mA, depending on model selected

Output Configuration: Inverse (0 to 10 VDC or 4 to 20 mA) Direct (10 to 0 VDC or 20 to 4 mA)

Voltage Output Slope:

- 3.28 mV/mm (83.3 mV/inch) using a 3.048 mm (10") span

- 1.64 mV/mm (41.7 mV/inch) using a 6.096 mm (20") span

Minimum Load Resistance: 1 K Ohms

- (5 K Ohms recommended for best accuracy)

Current Output Slope:

- 5.2 µA/mm (0.133 mA/inch) using a 3.48 mm (10") span

- 2.6 µA/mm (0.066 mA/inch) using a 6.096 mm (20") span

Maximum Load Resistance: 500 Ohms

### Analog Output Electrical Specifications

(Test conditions: 24 VDC, TA = 20° C, large flat target, still air, @ minimum span size of 3.048 m or 10')

	current output <sup>1</sup>	voltage output <sup>2</sup>
Output Range	4-20 mA	0-10 V
Load Resistance (Ohms)	10 to 500	1 K to ∞
Resolution <sup>3</sup>	4.88 µA	2.44 mVDC
Accuracy (% of span) <sup>4</sup>	± 0.50	± 0.40
Linearity (% of span)	± 0.15	± 0.15
Temperature Dependence (% of span/°C)	± 0.006	± 0.004

<sup>1</sup>tested with 250 Ohm load

<sup>2</sup>tested with 1000 Ohm load; a low value is recommended to minimize noise pickup

<sup>3</sup>resolution = span/4096; Maximum: 1.90 mm (0.071") for 8 meter, long-range model, max. span

<sup>4</sup>best accuracy may be limited to 2.117 mm (0.083") due to wave-skip phenomena



### Response Times - Minimum, Standard

150 ms on/off, 250 ms on/off  
Other response times are available.

### Indicators

Multicolored (Amber, Red, Green) LED:  
Indicates object position relative to the span limits.  
Red LED:  
Intensity increases as output signal increases.

### Connection Options

Cable Style Models:  
24 AWG, foil shield, lead-free PVC jacketed,  
4-conductor, 3 meters (10') long, standard  
Connector Style Models:  
4-conductor, straight and right-angle "micro" style

### Protection

Power Supply: current-limited over-voltage, ESD,  
reverse polarity  
Outputs: current-limited over-voltage, ESD,  
over-current

**NOTE:** This sensor is NOT RATED EXPLOSION  
PROOF.

### Environmental

Operating Temperature Range:  
-20° to 60° C (-4° to 140° F)  
Storage Temperature Range:  
-40° to 100° C (-40° to 212° F)  
Operating Humidity: 100%  
Protection Ratings: NEMA 4X, IP67  
Chemical Resistance: Unaffected by most acids,  
bases, and oils.

### Construction

Dimensions:  
Cable Model: 30 mm (1.181") dia. x 1.5 mm-6g  
threaded housing x 94.95 mm (3.738") mm  
long, including 34.70 mm (1.365") dia. x  
20.10 mm (0.790") long sensing bead  
Connector Model: 30 mm (1.181") dia x 1.5 mm-6g  
threaded housing x 95.99 mm (3.779")  
long; 117.15 mm (4.612") long, including  
AC132 right-angle, connector/ cable  
assembly; 125.00 mm (4.921") long,  
including AC130 straight, connector/cable  
assembly; sensing head dimension same  
as cable model.  
Housing: Epoxy encapsulated to resist shock  
and vibration  
Case: ULTEM®\* plastic (FDA Approved)  
Transducer Face: Epoxy - white  
Sensor Cables: Lead-free, black PVC jacketed

### Agency Approvals

CE Mark: CE conformity is declared to:  
EN63126: 1997 (annex A, industrial) including  
amendment A1:1998. EN55011 group 1 Class A.  
*Declaration of Conformity available upon request.*

\*ULTEM® is a registered trademark of The General  
Electric Co.

\*\*Available only in the stainless steel-faced, 1 m-span models

## Accessories

**Model AC130**, Straight, M12 micro, 4-conductor,  
connector/cable assembly, 5 m (16')

**Model AC132**, Right-angle, M12 micro, 4-  
conductor, connector/cable assembly, 5 m (16')

**Model AC233**, Small, right-angle, stainless,  
mounting bracket

**Model AC250-n**, Tank sensor mounting reducer,  
available with four different outside diameters;  
used with all SUPERPROX® SM900 family sensors.  
n = 1 (1 1/4" NPT); 2 (2" NPT); 3 (3" NPT);  
4 (4" NPT)

**Model AC251-n**, Tank sensor mounting flange,  
available with three different pipe thread  
diameters, furnished with matching AC250 Tank  
sensor mounting reducer; used with all  
SUPERPROX® SM900 family sensors. n = 2 (2"  
NPT); 3 (3" NPT); 4 (4" NPT)

**Model AC441A**, Handheld configurator

See Page 7-1 for accessory photos.

LED FOR ALL SM900 PRODUCTS  
Current LED change has been implemented  
Red New LED  
Amber

SUPERPROX® SM906  
SERIES

# Selection Chart

## SM906 Series

### Level/Distance with Analog Output

Model No.	12/24 VDC Power Version		Connection Style		Analog Span				Output Signal				Output state on loss of Echo Power Up				Transducer			Materials		Housing		Response Time	Functionality			
	Cable	Connector	51 mm - 1 m. 2" - 39"	120 mm - 2 m 4.7" - 79"	120 mm - 1 m 4.7" - 39"	203 mm - 8 m 8" - 26"	Inv. 0-10V	Dir. 0-10V	Inv. 4-20 mA	Dir. 4-20 mA	Minimum	Maximum	Hold on loss of echo min. on power up	Hold on loss of echo max. on power up	Silicone	Stainless	Fluorosilicone	Epoxy	30 mm ULTEM®	30 mm stainless	No Foreground or Background Suppr.	Foreground Suppr. (Object Mode)	Foreground Suppr. (Background Mode)		Fg & Bg Suppr. (Background Mode)			
SM906A-100000	■	■	■							■					■				■		25 ms	■						
SM906A-102000	■	■	■										■		■				■		25 ms	■						
SM906A-103100S	■	■	■											■	■				■		15 ms	■						
SM906A-111000	■	■	■									■			■				■		25 ms	■						
SM906A-120000	■	■	■												■				■		25 ms	■						
SM906A-122000	■	■	■												■				■		25 ms	■						
SM906A-122203	■	■	■												■				■		100 ms				■			
SM906A-122600S	■	■	■												■				■		2.50 s	■						
SM906A-132000	■	■	■												■				■		25 ms	■						
SM906A-133000FS	■	■	■												■				■		25 ms	■						
SM906A-400000	■	■		■											■				■		35 ms	■						
SM906A-400000S	■	■		■											■				■		35 ms	■						
SM906A-410000	■	■		■											■				■		35 ms	■						
SM906A-411000	■	■		■											■				■		35 ms	■						
SM906A-430000	■	■		■											■				■		35 ms	■						
SM906A-431000	■	■		■											■				■		35 ms	■						
SM906A-432000	■	■		■											■				■		35 ms	■						
SM906A-721000STS	■	■			■														■		25 ms	■						
SM906A-800000	■	■				■													■		250 ms	■						
SM906A-832000	■	■				■													■		250 ms	■						
SM956A-100000	■		■	■															■		25 ms	■						
SM956A-102000	■		■	■															■		25 ms	■						
SM956A-110000	■		■	■															■		25 ms	■						
SM956A-110000S	■		■	■															■		25 ms	■						
SM956A-111000	■		■	■															■		25 ms	■						
SM956A-120000	■		■	■															■		25 ms	■						
SM956A-122000	■		■	■															■		25 ms	■						
SM956A-123600S	■		■	■															■		2.50 s	■						
SM956A-130000	■		■	■															■		25 ms	■						
SM956A-130003S	■		■	■															■		25 ms	■			■			
SM956A-131000	■		■	■															■		25 ms	■						
SM956A-131101S	■		■	■															■		15 ms		■					
SM956A-132000	■		■	■															■		25 ms	■						
SM956A-132400S	■		■	■															■		500 ms	■						
SM956A-133000	■		■	■															■		25 ms	■						
SM956A-133003	■		■	■															■		25 ms	■			■			
SM956A-133600	■		■	■															■		2.50 s	■						
SM956A-400000	■			■															■		35 ms	■						
SM956A-402000	■			■															■		35 ms	■						
SM956A-410000	■			■															■		35 ms	■						
SM956A-412000	■			■															■		35 ms	■						
SM956A-420000	■			■															■		35 ms	■						
SM956A-420200	■			■															■		100 ms	■						
SM956A-430000	■			■															■		35 ms	■						
SM956A-432000	■			■															■		35 ms	■						
SM956A-432303	■			■															■		250 ms				■			
SM956A-733003STS	■				■														■		25 ms				■			
SM956A-800000	■					■													■		250 ms	■						
SM956A-820000	■						■												■		250 ms	■						

All possible sensor configurations are not listed here.

## SUPERPROX<sup>®</sup> Ultrasonic Counting Sensor



**Now there's accurate counting of containers over a wide range of sizes... even in the presence of "dither" or jiggling back and forth**

Accurate counting of containers on single-file conveying systems has challenged the container manufacturing, food processing and packaging, beer/beverage, and pharmaceutical industries for many years. The Model CT1000A series is an ultrasonic sensor designed especially for achieving accurate container counting.

The Model CT1000A ultrasonic counting sensor counts separated containers as well as those moving back-to-back at line speeds up to 2000 containers per minute. The accuracy is maintained in the presence of line stoppages, reversals, and container jiggling in front of the sensor. The sensor provides a setting for large versus small container sizes, and regular versus irregular container shapes.

The Model CT1000A sensor is capable of counting various size containers with a single setting

of the sensor as long as the proper spacing between the rails and containers is maintained and the distance from the sensor to the containers is not changed. This feature eliminates the need to stop the conveyor line and readjust the sensor each time there is a change in the container size or material.

Made of tough ULTEM<sup>®</sup>, the sensor measures 139.7 mm (5.50") long x 66.5 mm (2.62") wide x 78.7 mm (3.10") high. With protection ratings of IP67 and NEMA 4X, the sensor resists most acids and bases, including most food products. It is sealed to withstand dusty, noisy, noncondensing-humidity, high-pressure, washdown environments typically associated with beverage-filling operations. The transducer face of the sensor is made of silicone rubber.

### Operation

The Model CT1000A counting sensor must be mounted so the sensing face is parallel to the container or object moving past the sensor, and away from any threads at the top of certain containers. The sensing range, to the inside of the pass-line-rail, is 50.8 mm to 69.8 mm (2.0" to 2.75") for most size containers.

- *Compatible with most types of external counters and PLC's*
- *Counts accurately*
- *Counts a wide range of container sizes*
- *Counts irregular shaped containers*
- *Counts glass, metal, plastic, and composite containers*
- *Counts accurately at line speeds up to 2000 containers per minute*
- *CE certified*

As the Model CT1000A counts a container, its red LED flashes and its output generates a 20 millisecond pulse with which either an electronic counter, PLC, or other counting system keeps count.

The output pulse time becomes variable at line speeds above 1500 containers per minute, and is the time between containers divided by 2.

If containers move past the sensor in the opposite direction, the sensor remembers not to generate pulses until the containers move past the sensor in the correct direction. The sensor remembers up to 32,000 containers moving in the opposite direction.

The setup mode, which specifies the container size, container shape, and conveyor direction, is done through the two-digit numeric display and the setup push-button. The setup mode is saved in nonvolatile memory and thus retained when power is removed from the sensor.

The Model CT1500A-1400 counting sensor with jam detection is also available.

### CT1500A-0000 Counting Sensor

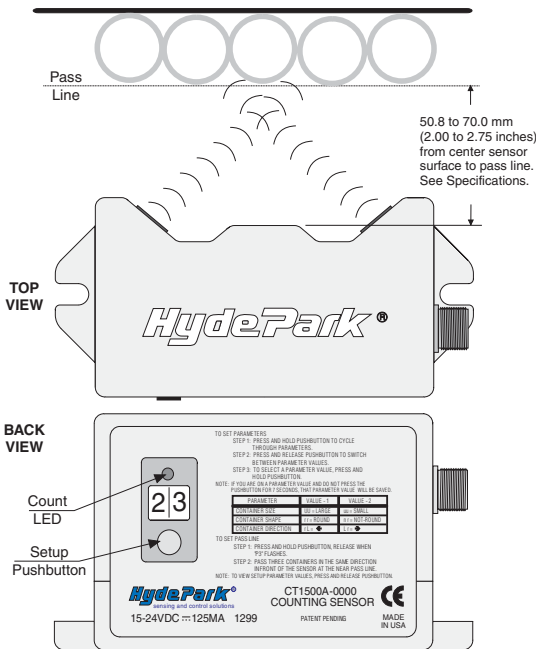

### How does it work?

During setup and operation, the CT1000A continually and accurately measures the elapsed time of every pulse echo reception between each pulse transmission for each of

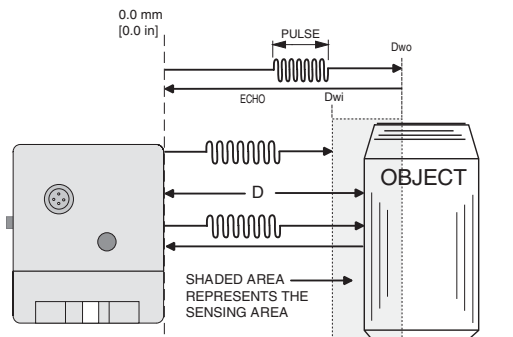

its transducers. The transmitted pulse begins a clock to register the elapsed times for the received pulse echoes. Given the elapsed time, the CT1000A software calculates the distance traveled out to the container and

## Model Reference Guide - CT1000A Series

Use the guide below to ensure the correct model number is specified for the application. Please note that not all sensor model combinations are available.

### EXAMPLE MODEL:

CT1 5 00 A-00 00-

**SUPERPROX® Product Series**

**Power/Connection Type**

0...15 to 24 VDC / cable style

5...15 to 24 VDC / connector style - STANDARD

**Sensing Function**

00...Standard counting

01...Velocity

**Design Level**

A...Applies to all models

**Operating Mode**

0...Standard

1...Counting with jam detection (3 transducer model)

**Output Type**

Counting with no jam output velocity and print control sensors:

0...Normally open (N.O. - NPN & PNP) - standard

1...Normally closed (N.C. - NPN & PNP)

2...Complimentary NPN outputs

3...Complimentary PNP outputs

Counting with Jam output:

4...Normally open (N.O. - NPN & PNP)

5...Normally closed (N.C. - NPN & PNP)

6...Normally open (N.O. - PNP & PNP)

7...Normally closed (N.C. - PNP & PNP)

**Special Functionality**

00...Standard

01...Divide by 10

02...Divide by 24

03...Divide by 100

10...Count up / down outputs

20...100ms pulse output

**Features and Options** - Optional

...No letter indicates no features or options

FS...Fluorosilicone transducer face

**Housing Types** - Optional

...No letter indicates standard ULTEM®\* plastic housing.

N...NORYL®\* Dairy 3A gray plastic housing

**Power Cable Length** - Optional

...No number indicates standard power cable length

/nn...Cable model, length of cable in feet

\*ULTEM® and NORYL® are registered trademarks of The General Electric Company.

back to the sensor, using the formula,

$$D = \frac{T * Vs}{2}$$

where: D = distance from the sensor to the object; T = elapsed time between pulse transmission and its echo reception, Vs = velocity of sound, approximately 1100 feet per second.

During operation, the calculated distance (D) is used by the CT1000A to determine the location and direction of each container as it passes by the unit. When each individual container is recognized to have passed by the sensor in the correct direction, the unit increments the digital display and pulses the output.

## Setup

Before using the counting sensor, the container size, shape, and direction must be set first; and then the pass line must be set. On the back side of the sensor is a 2-digit LED display and a setup push-button. Normally this display shows either a count or fault status. This 2-digit LED display and setup push-button are also used to set the container direction, size, shape, and the pass line for the containers. Momentarily pressing the setup push-button displays the container size, shape, and direction. This action clears the 2-digit LED display container count but does not affect the external counting device.

### Container Size, Shape, and Direction

Press and hold the setup push-button until the 2-digit LED display alternates a blank display with the current value for

the desired parameter, and then release the setup push-button. (The parameter displayed can be determined from the parameter value as shown in the table below, since the parameter values are all unique. When the setup push-button is first pressed and held for a few seconds, the 2-digit LED display first flashes P3 for pass line setup, and then continues to the setup parameters. To change the parameter to the other value, press and release the setup push-button. To save the current parameter value as the selected value for the parameter, either press and hold to move to the next parameter; or wait 7 seconds for the parameter setup to timeout. After the setup push-button is not pressed for 7 seconds, the selected value for each setup parameter is saved in nonvolatile memory, and the display returns to normal operation.

### Pass Line Setup

The sensor must be mounted so that the containers pass the sensor at a fixed distance from the sensor. Press and hold the setup push-button until the 2 digit LED display flashes P3 and then release. Next move 3 containers past the sensor at the near edge of the pass line. After each container passes the sensor, the digit following the P is decremented. After the 3rd container passes the sensor, the pass line is set, and the 2 digit LED display returns to displaying a container count. If you wish to abort the pass line setup, press and release the setup push-button. If you press and hold, the sensor switches to container size, shape, and direction setup mode.

## Electrical Wiring

### Count - NPN/PNP

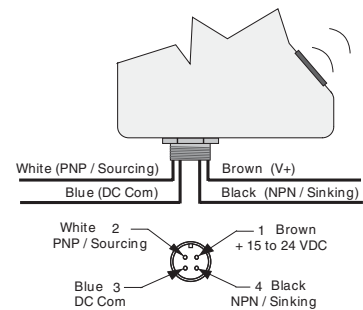

### Count - NPN/PNP

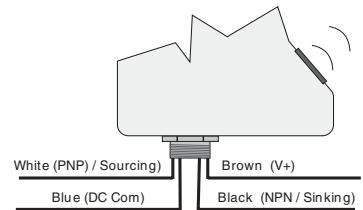

### Count - NPN

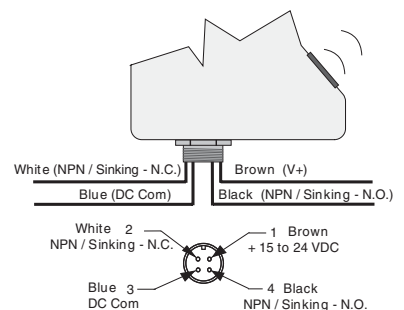

### Count - PNP

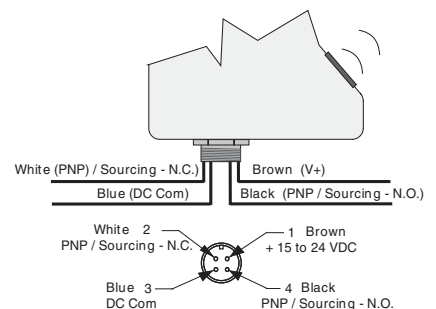

Parameter	Value 1	Value 2
Container Size	UU = large (2.0" - 12.0" approx.)	uu = small (1.5" - 2.0" approx.)
Container Shape	rr = round	nr = not round
Container Direction	rL = ← (right/left)	Lr = → (left/right)

## Electrical Wiring

### Count/Jam - NPN/NPN

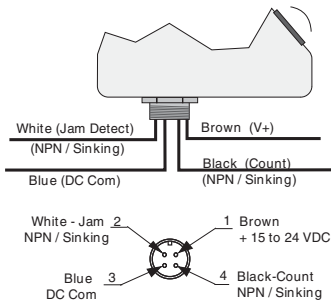

### Count/Jam - PNP/PNP

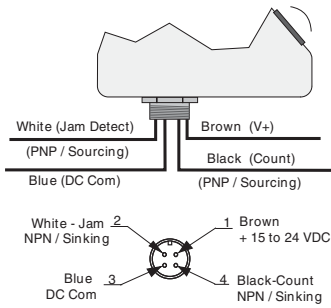

### NPN Outputs

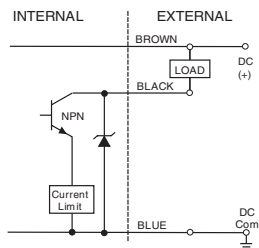

### PNP Outputs

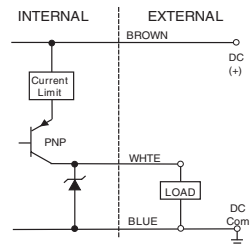

## Dimensions

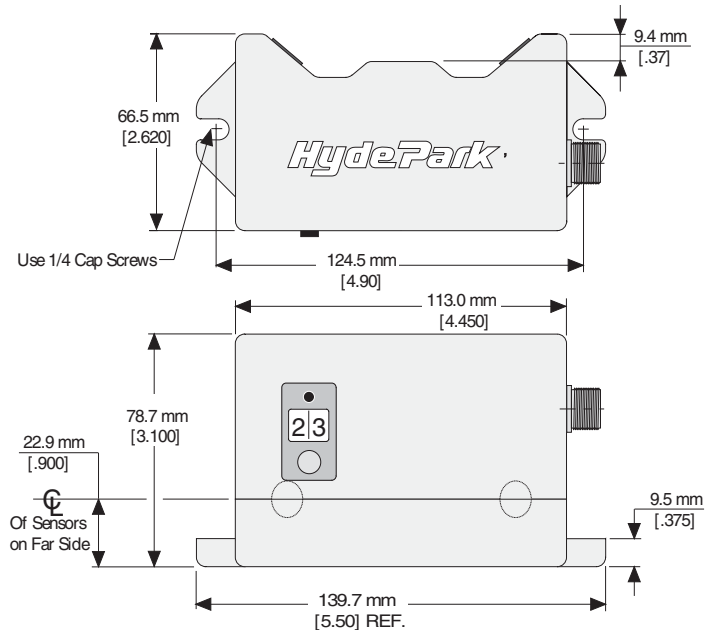

## Accessories

**AC130** Straight, M12 micro, 4-conductor, connector/cable assembly, 5 m (16'), for 30 mm, barrel-style sensors

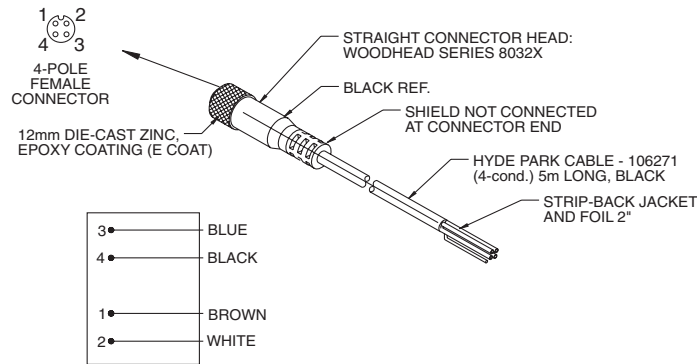

**AC132** Right-angle, M12 micro, 4-conductor, connector/cable assembly, 5 m (16'), for 30 mm, barrel-style sensors

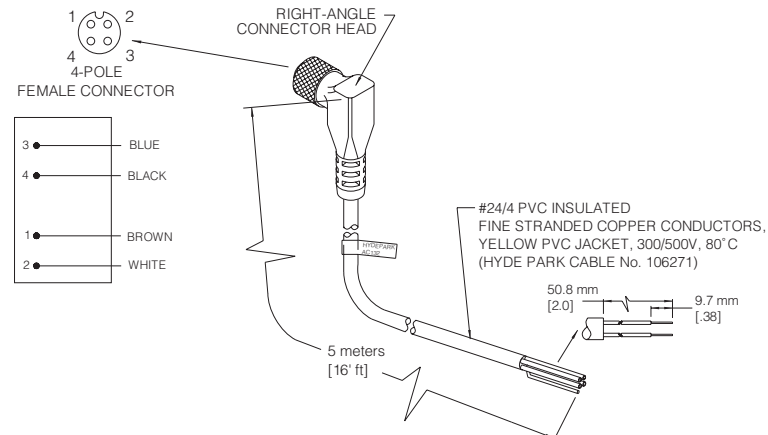

## Accessories, con't.

### AC234 Mounting bracket

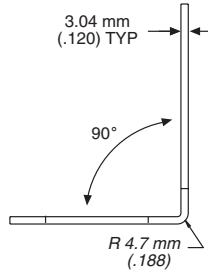
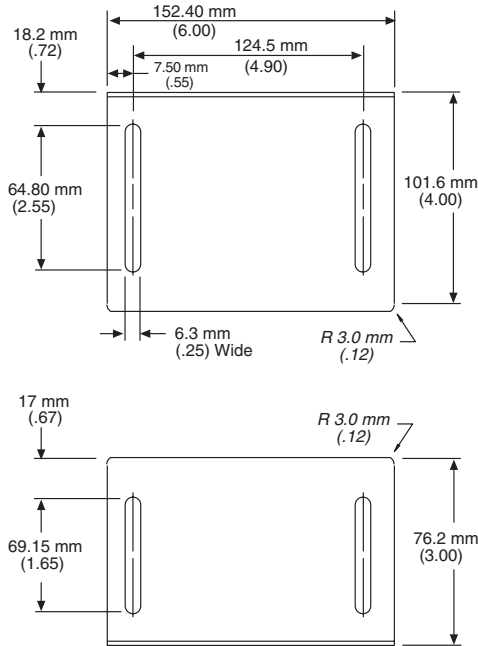

## General Specifications

### Power Supply

Supply Voltage: +15 to 24 VDC  $\pm$  10% regulated supply  
 Current: 125 mA max. (excluding load)  
 Protection: ESD and reverse-polarity

### Sinking Output

Maximum on-state voltage @ 100mA: 0.37 V  
 Maximum load current: 100 mA  
 Maximum applied voltage: 30 VDC  
 Protection: ESD and over-current

### Sourcing Output

Maximum on-state voltage drop @ 100mA: 0.50 V  
 Maximum load current: 100 mA  
 Maximum output voltage: Equal to supply voltage  
 Protection: ESD and over-current

### Temperature

Operating Temperature: 0°C to 50°C (32°F to 122°F), @ 100% relative humidity  
 Storage Temperature: -40°C to 100°C (-40°F to 212°F)

### Maximum Rail Separation

Container diameter plus 6.3mm (0.25")

### Distance from Center Face to Near Pass Line

Small containers 38.1mm (1.5") to 50.8mm (2.0") dia.  
 50.8 mm to 63.5 mm (2.00" to 2.50")  
 Large containers 50.8mm (2.0") to 305mm (12.0") dia.  
 50.8 mm to 69.8 mm (2.00" to 2.75")

### Maximum Counting Rate

2000 containers per minute

### Sonic Frequency

500kHz

### Sensor Dimensions

W= 66.5 mm, L= 139.7 mm, H= 78.7mm  
 (W= 2.62 in, L= 5.50 in, H= 3.10 in.)

### Sensor Connector

4 pin connector  
 Use either AC130 or AC132 sensor cable (Must be purchased separately)

### Sensor Materials

Housing: Epoxy filled to resist shock and vibration  
 Case: ULTEM®\* (FDA Approved)  
 Face: FDA approved silicone rubber  
 Optional Cable: Non-toxic PVC jacket  
 2-digit LED Window: LEXAN\*

### Sensor Ratings and Approvals

NEMA 1, 3, 4x, 12, 13, and IP67  
 CE mark compliant  
 Declaration of conformity available upon request.

\*ULTEM® and LEXAN® are registered trademarks of The General Electric Company.

## Accessories

**Model AC130.** Straight, M12 micro, 4-conductor, connector/cable assembly, 5 m (16'), for connector-style sensors

**Model AC132,** Right-angle, M12 micro, 4-conductor, connector/cable assembly, 5 m (16'), for connector-style sensors

**Model AC234,** Counting sensor bracket

See page 7-1 for accessory photos.

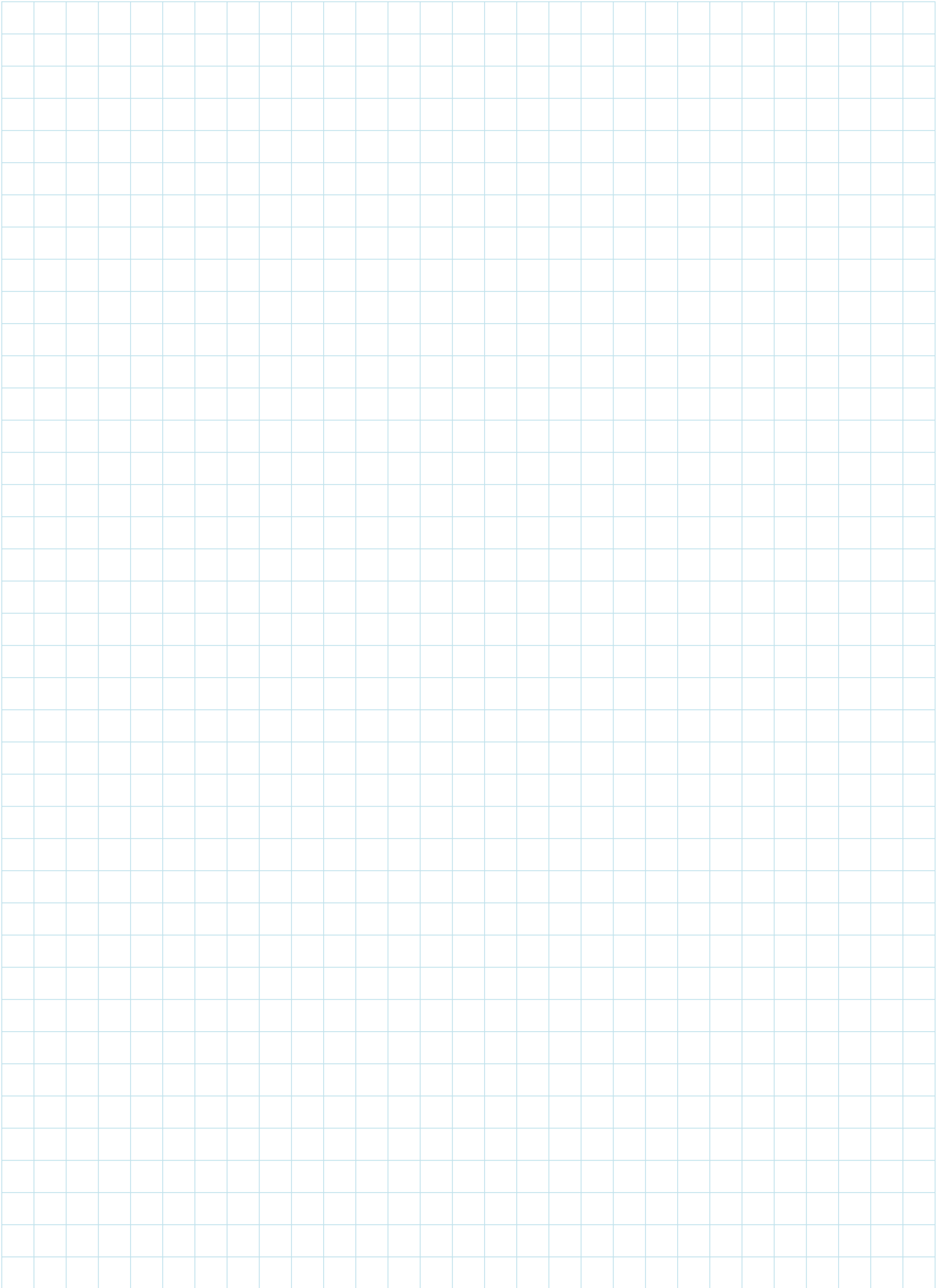





**SUPERPROX+™ allows in-the-field programming of SUPERPROX sensors by the user**

SUPERPROX+ software combined with the Model AC441A configurator interface module allows the user to now load either standard or custom sensing configurations into the SUPERPROX® 300, 600, 606, 900, and 906 series sensors designated with an 'SC' prefix model number.

The 'SC' prefix designator has been assigned in order to differentiate these field programmable sensors from the factory configured sensors designated with an 'SM' prefix model number. The SUPERPROX+ software will not operate with 'SM' series sensors to prevent possible alteration of the factory loaded configuration defined by the specific sensor model number.

All the unique sensing capabilities and functions available in "SM" sensor models of the

SUPERPROX® 300, 600, 606, 900, and 906 series are also available, plus additional capability and functionality in the equivalent field programmable "SC" sensor models. The onboard processor used in the "SC" sensor models has an EEPROM. This gives the user the option to write over an existing sensor program configuration as many times as necessary until it is exactly correct for the intended application.

SC sensor models offer the option to lockout the limits setup push-button. Through the SUPERPROX+ software, the limits setup push-button in the SC900 and 906 series sensors can be inhibited for protecting the limits from being changed .

**More than just a program configurator**

The Model AC441A configurator interface module serves as both a program downloading as well as an uploading interface for all 'SC' sensor models. In addition, the

*Configuration Package for Field Programming SUPERPROX® Sensors*

- *Model AC441A configurator serially downloads and uploads all sensor program configurations*
- *Windows-based configuration program with functionality graphics*
- *Allows user to configure SUPERPROX sensors in the field*
- *Field programmable models SC300/600/606/900/906 series*
- *Increase sensing capability & flexibility over SM series equivalent*
- *Remote limit setup in SC & SM900/906 series sensors*
- *Limits push-button lockout option in SC900/906 series sensors*
- *CE certified*



Model AC441A can be used as a stand-alone limits setup calibrator for setting the sensing or span limits at specific distances from the sensor in SC900 and 906 series sensors through the aid of its four digit LED display. With either model SC900 or 906 series sensor connected to the Model AC441A and powered, whatever settings have been set through the limits push-button can be read from the Model AC441A display. The actual sensing distance between a sensor and the object being sensed can also be read in real time from the Model AC441A display to verify sensor operation with either the model SC900 or 906 series sensor.

### Operation

The SUPERPROX+ software with the Model AC441A configurator interface module enables the SC300, 600, 606, 900, and 906 series sensors to be configured in the field with a wide range of unique sensing capability. Besides this feature, the SUPERPROX+ software visually simulates on the computer screen the LED sensing status and output functionality with a simulated target. With this visual graphic aid, the various sensing and operating parameters representing a configuration can be checked prior to loading into the sensor for verifying the functionality is correct for the application.

Another feature of the SUPERPROX+ software allows the SC300, 600, 606, 900, and 906 series sensors to be configured with either an equivalent standard series 'SM' model or a user custom program configuration. A custom program may be changed any number of times due to the EEPROM/memory used in these sensors. An 'SM' series sensor configuration can be copied, modified, and saved in a custom file directory, but cannot be changed in or deleted from the standard file directory.

A user information drop-down message will appear at each program parameter block in every configuration to give explanation or instruction of the individual functionality. By placing and pausing the cursor over any one of the parameter blocks, a drop-down message automatically appears to explain that particular functionality in the configuration.

All dimensional units for displaying the various distances associated with a configuration like sensing limits, range, deadband, etc. is selectable in either English or metric measure. This is simply selected through the "setup" drop-down menu.

## Model Reference Guide - SC Configurable Series

Use the guide below to ensure the correct model number is specified for the application. Please note that not all sensor model combinations are available.

### EXAMPLE MODEL:

**SC6 0 6 A - B C 0 FP**

#### SUPERPROX+ Product Series

- SC3...Miniature configurable models
- SC6...18 mm and flat-profile configurable models
- SC9...30 mm threaded barrel configurable models

#### Power/Connection Type

- 0...12 to 24 VDC/cable style
- 5...12 to 24 VDC/connector style

#### Sensing Function

- 0...Discrete output - proximity
- 6...Analog output (SC6 and SC9 only)

#### Design Level

- A...Applies to all models

#### Maximum Far Limit

##### SC3 Series

- 4...102 mm (4")

##### SC6 Series

- B...254 mm (10")

##### SC9 Series

- 1...51 mm to 1 m (2" to 39")
- 4...120 mm to 2 m (4.7" to 79")
- 7...120 mm to 1 m (4.7" to 39") - Required for ST option
- 8...203 mm to 8 m (8" to 26')

#### Output Signal

- 0...Discrete models
- V...Analog models - voltage output
- C...Analog models - current (mA) output (except SC606 barrel style)

#### Functionality

- 0...Standard

#### Options

- ...No designator indicates no options
- ST...Stainless transducer (must also specify stainless housing/120 mm to 1 m range models only)
- FS...Fluorosilicone transducer face

#### Housing Types

- ...No designator indicates standard ULTEM®\* plastic barrel housing
- FP...ULTEM® flat-profile housing
- S...SS303 stainless steel - 18 mm or 30 mm barrel housing

\* ULTEM® is a registered trademark of the General Electric Company.

## Model Reference Guide - AC441A Configurator Series

Use the guide below to ensure the correct model number is specified for the application. Please note that not all sensor model combinations are available.

- AC441A-1...US Version - with 110VAC power supply inline
- AC441A-2...UK Version - with 220VAC power supply, inline
- AC441A-3...European Version - with 220VAC power supply, inline
- AC441A-US...Complete configuration package including: AC441A-1 configurator, 1 AC130-3 cable, 1 AC137 adapter, and 1 AC172 RS232 cable.

NOTE: All AC441A series models are supplied with SUPERPROX+™ software CD, power supply for appropriate country, and mounting bracket.

## Requirements

There are three basic peripheral items required to acquire full field configuring capability. In addition to the SUPERPROX+ software and the Model AC441A configurator interface module, the only other item is a straight-through DB9 serial port cable. This item is available from Hyde Park as a Model

AC172 accessory cable option.

The SUPERPROX+ software is compatible for operation on all Windows 95, 98, ME, 2000, or XP operating systems.

Only SUPERPROX® 300, 600, 606, 900, and 906 series sensors having an 'SC' prefix in the model number may be configured in the field with this software.

## Electrical Wiring

The sensor wires must be run in conduit free of any AC power or control wires.

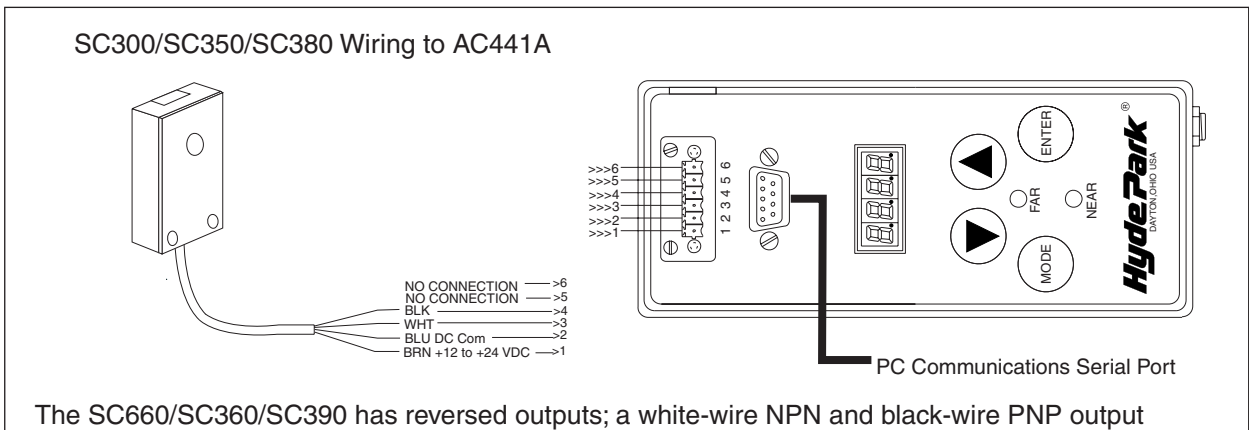
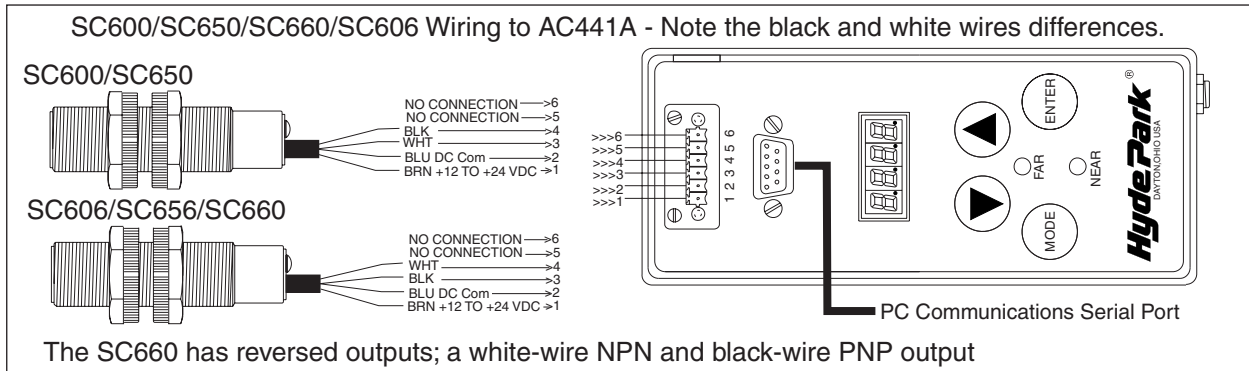
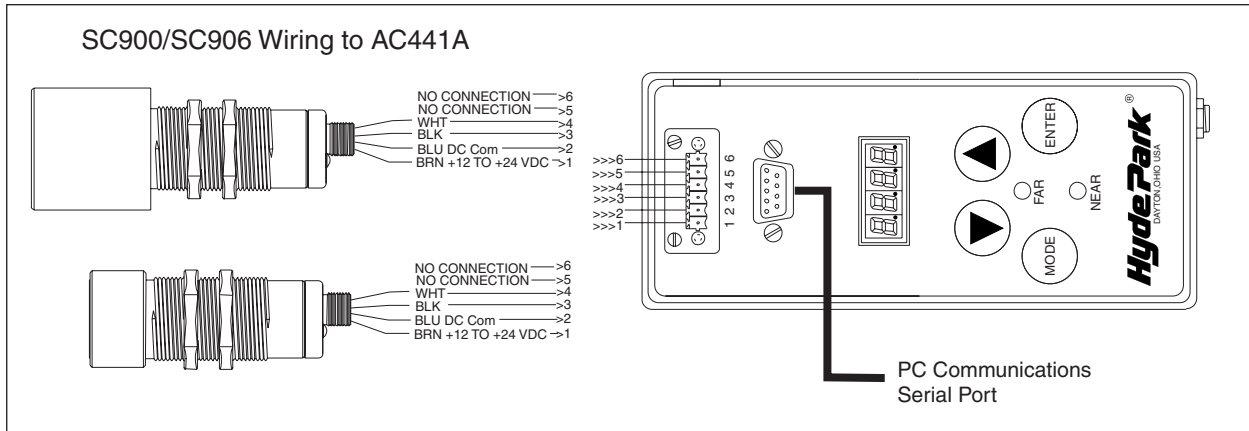

## Dimensions

### AC441A

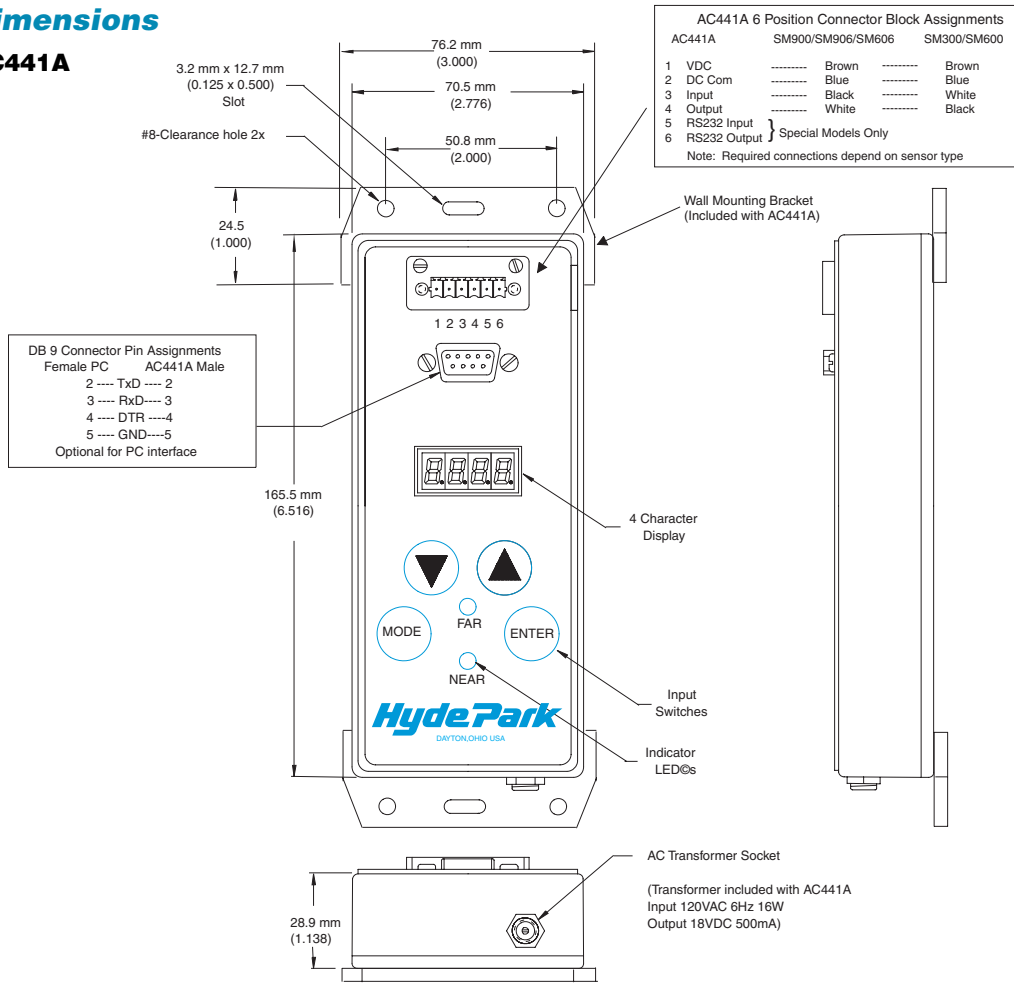

## General Specifications

### Model AC441A

#### Power Requirements

18 to 24 volts DC, 175 mA max. (includes power supply to sensor)

#### Power Connector

5.5 x 2.1 mm jack center negative

#### Power Supply

In-line, universal input: 85VAC to 265VAC, 50/60Hz  
Output: 24VDC, 0.63A  
Supplied with country-specific AC line cord/plug and DC output cord. Both cords are 6' in length.

#### Other Connections

6-pin quick disconnect for sensor DB9 female connector for PC interface.

#### Sensor Mounting Distance

47 m (150') maximum

#### Display

4-digit 7 segment 0.4" tall red LED with decimal point

#### Dimensions

6.37" (152 mm) x 2.76" (70 mm) x 1.15" (29 mm)

#### Operating Temperature

0° to 50°C (32° to 122°F) @ 10-90% non-condensing humidity. Not suitable for permanent outdoor use.

#### Ratings and Certifications

CE mark compliant  
Declaration of Conformity available upon request

## Accessories

**Model AC137**, Micro to pico adapter

**Model AC172**, DB9, RS232 straight-through cable, 2 m (6')

See page 7-1 for accessory photos.



*Sensors for device-level networks for industrial automation*

**DeviceNet™ sensors are compatible with the world's leading device-level network for industrial automation**

Hyde Park offers sensors that are compatible with DeviceNet. Both analog and proximity versions of the SM650/SM656 flat-profile and the SM950-SM956 1,2, and 8 meter range are available.

These sensors can communicate at either 125k, 250k, or 500k baud rates and can be set to any MACID address from 1 to 63. Both the communication rate and the MACID address can be changed by the user.

The DeviceNet sensors have two multicolor LEDs to show the sensing and network status. The sensing status multicolor LED indicates distance to the object relative to the span limits. The module/network multicolor LED indicates the status of the sensor with the DeviceNet network. The sensors are provided with EDS files with which a program, such as RSNetwork, can configure the operation of the sensor.

**Analog DeviceNet sensor**

The analog version of the DeviceNet sensor reports a

numeric value which is proportional between the analog span limits. The near and far analog span limits can be configured along with the numerical value that should be reported at each limit. The minimum and maximum numerical value can be set at either analog span limit. Many parameters can be specified, such as averaging, loss-of-echo operation, and alarm limits.

**Proximity DeviceNet sensor**

The proximity version of the DeviceNet sensor reports the value of two independent outputs. The near and far limits can be configured along with the action of the two independent outputs. The outputs can be configured to function as a proximity sensor, dual-level high/low, dual-level alarm, or dual-level setpoint. The loss-of-echo operation can be set independently for both outputs. Also, the on and off delays for the 2 outputs can be set independently.

These sensors are provided with micro connector male connectors that conform to the DeviceNet point specification. The sensors operate over the full range of the valid DeviceNet voltage specifications (+11 to 25 volts).

- Available for both analog and proximity sensors
- Ability to set many different parameters, such as averaging, loss-of-echo, and alarm limits
- Allows user to use products from a variety of manufacturers

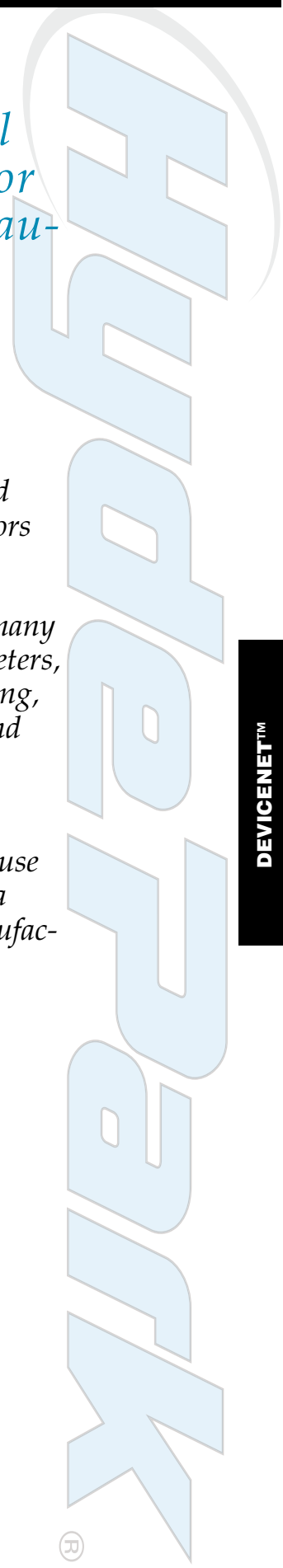

**DEVICENET™**

## Model Reference Guide - DeviceNet Series

Use the guide below to ensure the correct model number is specified for the application. Please note that not all sensor model combinations are available.

### EXAMPLE MODEL:

**SM9 5 6DN-152 9 1 1 -**

#### SUPERPROX® Product Series

SM6...Flat-profile sensor  
SM9...30mm threaded barrel

#### Power/Connection Type

5...12 to 24 VDC / connector style

#### Sensing Type

ODN-153...Discrete  
6DN-152...Analog

#### Housing

6...Flat-profile sensor  
9...30mm threaded barrel

#### Measurement Units

1...English  
2...Metric

#### Sensing Range

SM6 Flat-profile  
0...31.8 mm to 254 mm (1.25" to 10")  
SM9 30mm barrel  
1...51 mm to 1 m (2" to 39")  
4...120 mm to 2 m (4.7" to 79")  
6...120 mm to 1 m (4.7" to 39") - FS option [only valid range]  
7...120 mm to 1 m (4.7" to 39") - ST option [only valid range]  
8...203mm to 8 m (8" to 26')

#### Options

...No designator indicates no options  
ST...Stainless transducer (must specify stainless housing)  
Available in SM9-1m range only  
FS...Fluorosilicone transducer face  
Available in SM6 or SM9 (120 mm to 1 m range only)

#### Housing Types

SM6 Flat-profile  
FP...Flat-profile - Must be specified  
SM9 30mm barrel  
...No designator indicates standard ULTEM®\* plastic housing  
1nn..125K  
2nn..250K  
5nn..500K  
S...SS303 stainless steel

\* ULTEM is a registered trademark of The General Electric Company.

## Wiring Connections



## Wiring Guidelines

MAXIMUM LENGTHS	125KBPS	250KBPS	500KBPS
Thick Trunk	500m (1640ft)	250m (820ft)	100m (328ft)
Thin Trunk	100m (328ft)	100m (328ft)	100m (328ft)
Single Drop	6m (20ft)	6m (20ft)	6m (20ft)
Cumulative of all Drops	156m (512ft)	78m (256ft)	39m (128ft)

# MICROSONIC® 100/400/700/800 Series Introduction

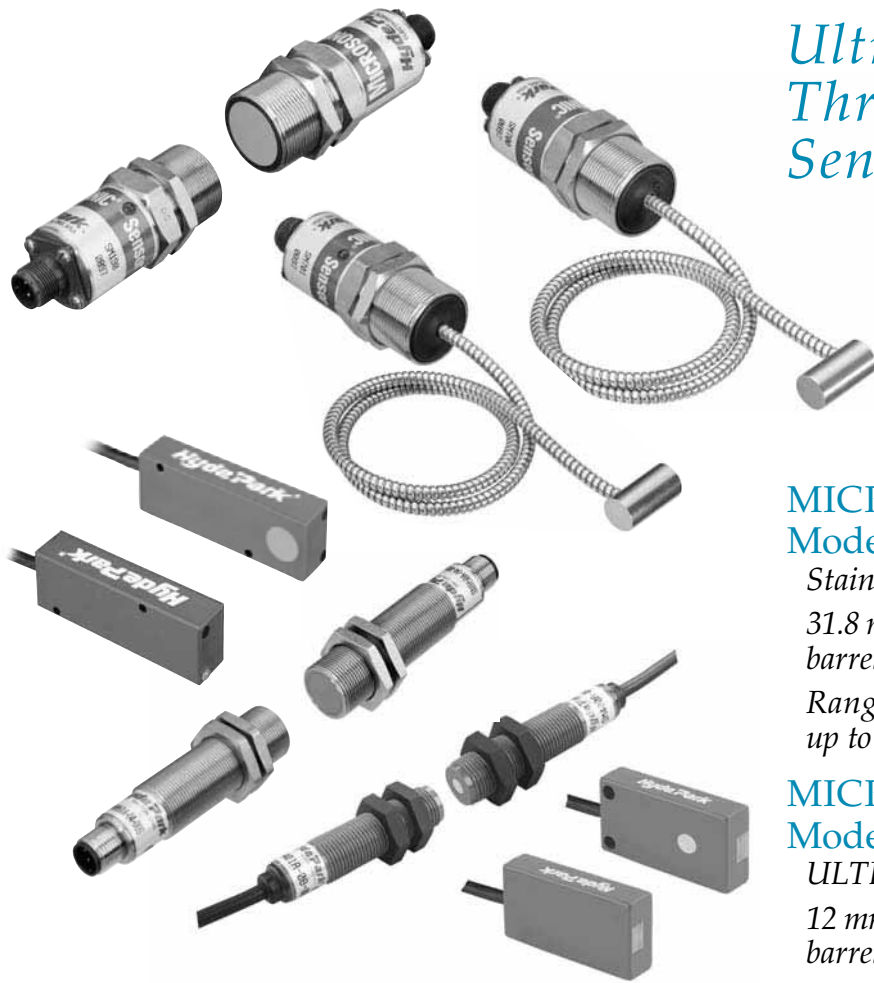

## Ultrasonic Thru-beam Sensors

### MICROSONIC® Model SM100 Series

*Stainless steel*  
31.8 mm (1.25")  
barrel style  
Range:  
up to 1829 mm (72")

### MICROSONIC® Model SM400 Series

*ULTEM® plastic*  
12 mm (0.47")  
barrel or flat-profile style  
Range: up to 203 mm (8")

### MICROSONIC® Model SM700 Series

*Stainless steel*  
31.8 mm (1.25")  
barrel style with  
13 mm (0.5") x 25 mm  
(1") remote probes  
Range: 381 mm (15")

### MICROSONIC® Model SM800 Series

*ULTEM® plastic*  
18 mm (0.71")  
barrel style or  
Flat-profile style  
Range:  
up to 1016 mm (40")

## Introducing the world's finest ultrasonic thru-beam sensors

From the early MICROSONIC® SM100 Series to the latest MICROSONIC® SM400 Miniature Series and SS100 Web Sensing System, these Hyde Park noncontact sensors have earned the reputation as the best performing, ultrasonic, thru-beam sensors on the market. Wet, harsh environments, dust, ambient light, high noise levels, frequent high-pressure washdowns, and severe-duty applications are everyday working conditions for the tens of thousands of MICROSONIC® thru-beam sensors in operation today.

These sensors offer significant benefits, primary of which are

accuracy and reliability. Once set up and operating, the MICROSONIC® sensors need very little attention. Even in dusty and messy environments, these sensors reliably detect most materials...especially clear glass, plastic, film, and irregular-shaped objects...an important advantage over many photoelectric sensors. Changing light conditions and colors have no effect on sensing capability and no sensitivity adjustments are required to compensate for inconsistent materials.

Rugged and robust, all MICROSONIC® thru-beam sensors offer a wide variety of sensing ranges, signal strengths and transmitter/receiver combinations to satisfy countless sensing needs while contributing significantly to increased productivity.

## Operation

The MICROSONIC® sensors are continuous-wave devices that consist of an ultra-high-frequency transmitter and receiver positioned opposite each other, illustrated at right, at a distance of up to 1829 mm (72"). During operation, the transmitter sends a continuous ultrasonic beam which is picked up by the receiver. When an object of any material or shape passes between the transmitter and receiver and breaks the beam, object presence is detected and the output of the receiver switches. Or, when a hole as small as 3 mm (1/8") diameter allows the beam to pass through to the receiver, the output of the receiver switches.

## Applications

In general, the Hyde Park line of MICROSONIC® ultrasonic thru-beam sensors are an excellent solution for applications requiring the accurate and reliable detection of objects of any material or shape within a range of 1829 mm (72"). While the kinds of applications are almost unlimited, the MICROSONIC® sensors are of particular value in tough sensing situations where the environment renders many other types of sensors inaccurate and unreliable. Take, for example, a procession of just-filled glass bottles moving rapidly from the capper on a packaging line. A sensor is detecting the leading edge of each bottle to ensure that, at the precise split second, accurate inspection will be made of the caps' presence. The line stops suddenly. It is discovered, upon inspection, that the sensor is covered with product or some other contaminant. The result is a false signal indicating a possible line backup that isn't really there...and a loss in valuable production time. The MICROSONIC® thru-beam sensor is an excellent solution in this particular application.

For applications specific to the various series of MICROSONIC® sensors, see either the product information sections that follow or the Application/Sensor Selection Chart on page 2-1.

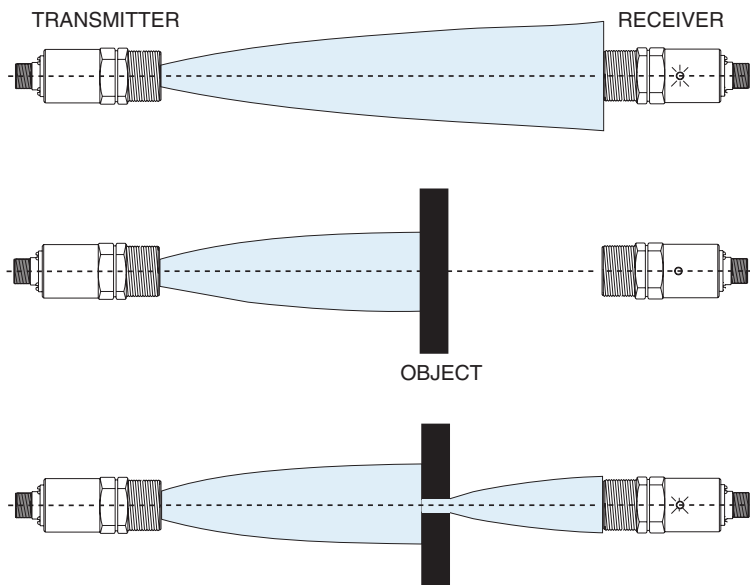



*MICROSONIC®  
Thru-beam  
Sensors*



**Industry proven, these MICROSONIC® sensors increase “uptime” with reliable, thru-beam sensing in harsh, high-speed environments**

In response to problems directly attributed to the harsh environments in which sensors operate today, Hyde Park offers broad application solutions with this industry-proven line of ultrasonic thru-beam sensors. First produced in 1974, the MICROSONIC® SM100 series sensors is the “workhorse” of the Hyde Park product line with tens of thousands of units continuing to perform a variety of thru-beam sensing functions throughout the world.

Using the world’s leading ultrasonic sensing technology,

the MICROSONIC® SM100 series sensors performs precise object detection...from transparent containers to metal parts as small as 6.4 mm (1/4”) diameter at speeds in excess of 2000 units per minute.

Unlike photoelectrics, these stainless steel sensors are virtually unaffected by splashing food, caustic cleaning solutions, frequent high-pressure washdowns, humidity, changing light conditions or colors, dust, and ambient noise. The rugged sensors need no maintenance and require no sensitivity adjustments to compensate for inconsistent product materials.

Response times range from 4 ms down to 0.6 ms. The 12 to 24 VDC circuitry and output signal make these sensors directly compatible with many programmable logic controllers, computers, and other logic control systems.

- *Self contained*
- *Meets NEMA 4X & IP67 standards*
- *Survives harsh environments*
- *No sensitivity adjustments*
- *Sensing ranges up to 1829 mm (72”)*



**MICROSONIC® SM100  
SERIES**

## Operation

The MICROSONIC® sensors are continuous-wave devices that consist of an ultra-high-frequency transmitter and receiver positioned opposite each other, illustrated below, at a distance of up to 1829 mm (72"). During operation, the transmitter sends a continuous ultrasonic beam which is picked up by the receiver. When an object of any material or shape passes between the transmitter and receiver and breaks the beam, object presence is detected and the output of the receiver switches. Or, when a hole as small as 3 mm (1/8 inch) diameter

allows the beam to pass through to the receiver, the output of the receiver switches.

With all circuitry compactly sealed in the stainless steel transmitter and receiver probes, the MICROSONIC® sensors boast a narrow, constant, high-frequency sonic beam for high sensing resolution.

The thru-beam sensing mode is set up by mounting the sensors on the same axis opposite each other as shown in Figure 1. The distance (range) between the transmitter face and receiver face

can be up to 1829 mm (72"), depending on the model and range selected.

Positioning of the transmitter and receiver for operation is extremely important for the reliable detection of objects, particularly small ones. As the figure also shows, the width of the transmitted sound beam initially expands at a rate of 10 degrees (5 degrees each side of the common axis) as the distance between the transmitter and receiver increases. This means that, if the distance between the transmitter and receiver is too great and the object is too small, it is possible for the beam to "wrap around" the object enough to not cause the receiver output to switch, as shown in Figure 2.

Therefore, reliable detection of 13 mm (0.5") inch wide or smaller objects is achieved when the objects are allowed to pass near the face of either the transmitter or receiver. An alternative approach is to position the transmitter and receiver on parallel axes, as shown in Figure 3, so as to reduce the amount of beam reaching the receiver.

Where sensing distances are adversely affected as the environment becomes more contaminated, the MICROSONIC® sensors remain constant under adverse conditions where other sensor types fail.

## Transmitter/Receiver Combinations and Sensing Ranges

Because specific sensing needs vary from one type of application to another, the MICROSONIC® SM100 series offers a variety of sensing ranges, connections, and signal strengths to maximize efficiency and productivity. See the Sensor Selection Chart in this section for the best transmitter and receiver combination.

## Mounting

The MICROSONIC® thru-beam sensors should be mounted in brackets that allow them to be adjusted for proper alignment on the same axis. Hyde Park offers the Model AC201 stainless, right angle, single-thru-beam, mounting bracket, which is illustrated, with dimensions, on Page 5-6.

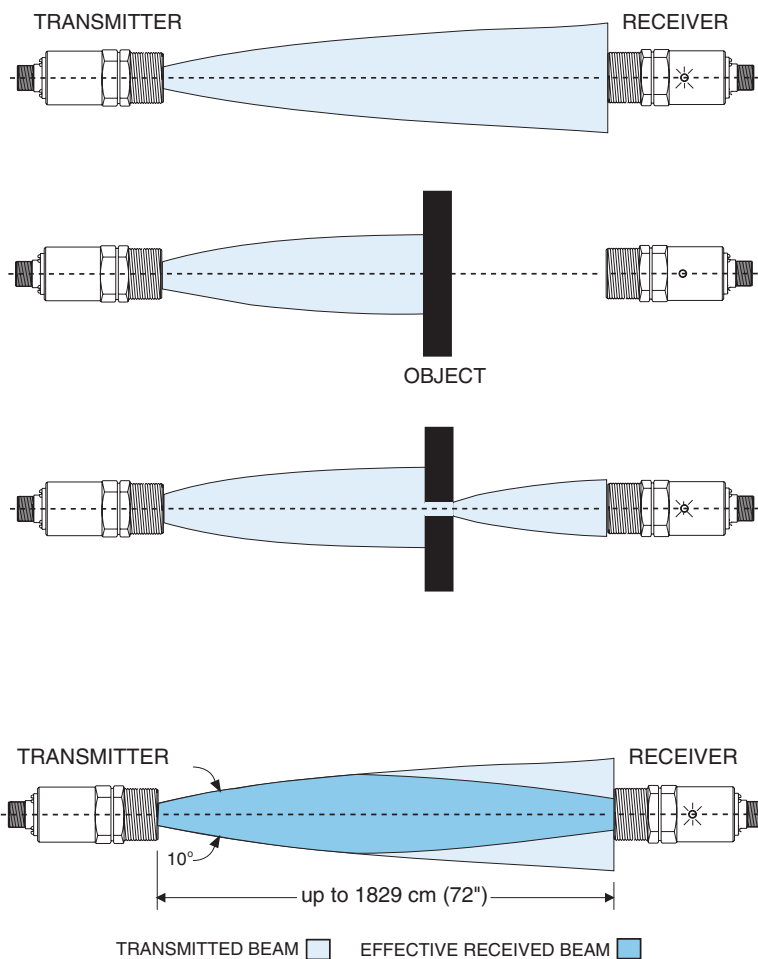

Figure 1, Thru-beam Pattern and Range

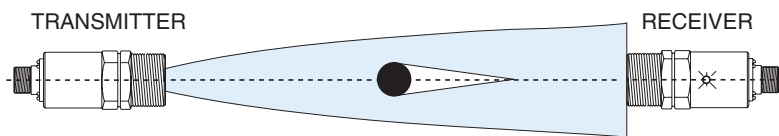

Figure 2

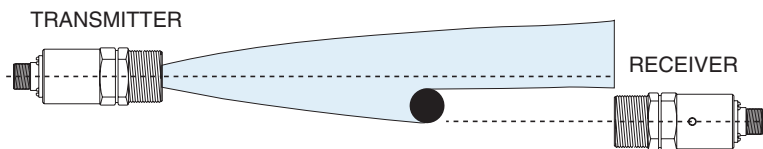

Figure 3

## Electrical Wiring

### Cable Style\*\*

Transmitter Models, Standard Cable  
Length 3 m (10')

SM121, 126, 139, 141, 145, 147

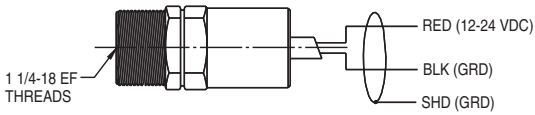

Receiver Models, Standard Cable  
Length 3 m (10')

SM171\*, 176, 187, 189, 191, 193, 195,  
198, 199, 251, 258, CS101

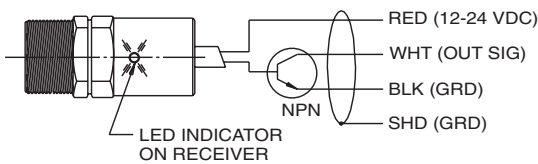

\* Operates only on 15 VDC power

\*\* Use Belden Cable No. 8423 and No. 9154 to extend receiver and transmitter cable length, respectively. Maximum recommended cable length is 152 m (500').

### Quick-disconnect (Amphenol) Style\*\*

Transmitter Models with Model AC100 Amphenol, 2-conductor, 3 m (10')  
Mating Connector Cable:

SM120, 125, 128, 138, 140, 146

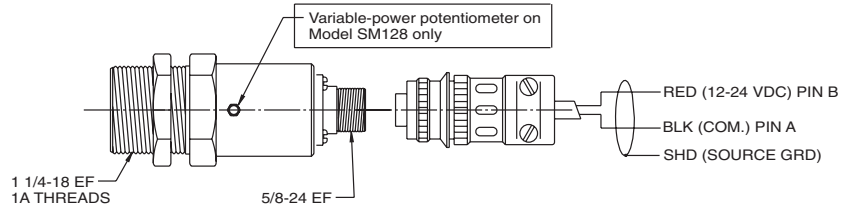

Receiver Models with Model AC150 Amphenol, 3-conductor, 3 m (10')  
Mating Connector Cable:

SM170, 175, 182, 186, 188, 190, 193C, 194, 198C, 199C, 250

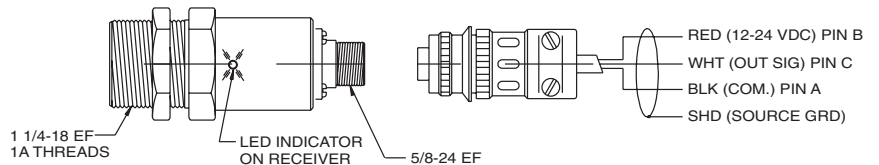

### Quick-disconnect (watertight) Style

Transmitter Models with Model AC107  
"Mini" 2-conductor, 7/8-16 mini, 4 m  
(12') Mating Connector Cable

SM138WTC, 140WTC, 146WTC

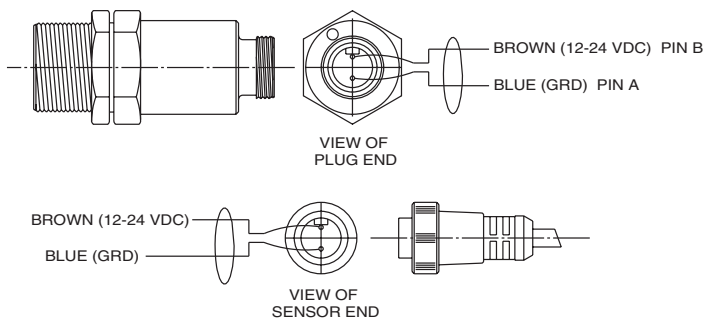

Receiver Models with Model AC108  
3-conductor, 7/8-16 mini, 4 m (12')  
Mating Connector Cable

SM186WTC, 190WTC, 250WTC,  
252WTC, 256WTC

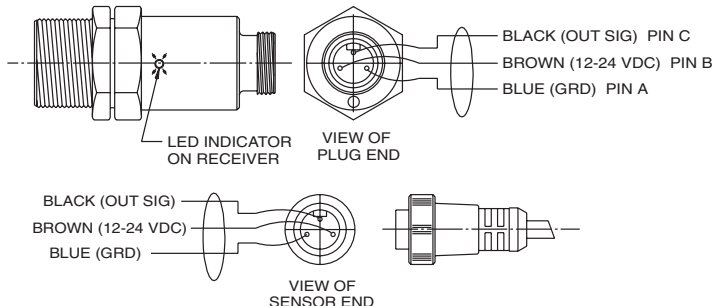

### Receiver Outputs

#### NPN SINKING\*\*\*

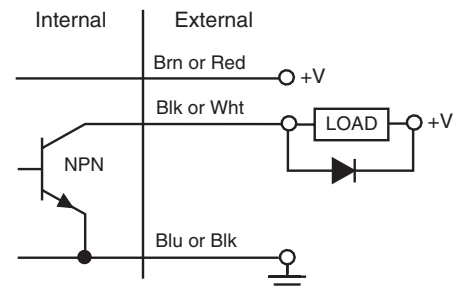

#### PNP SOURCING\*\*\*

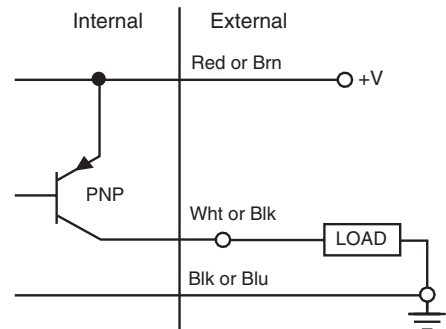

\*\*\* Cable conductor colors vary, dependent upon the sensor model number.

## Dimensions

### Cable Style

Transmitter Models: SM121, 126, 139, 141, 145, 147

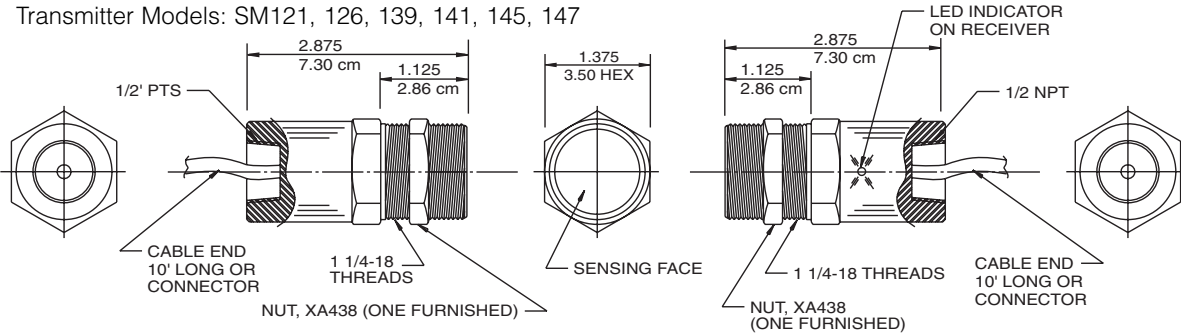

Receiver Models: SM171, 176, 187, 189, 191, 193, 195, 198, 199, 251, CS101

### Quick-disconnect (Amphenol) Style

Transmitter Models: SM120, 125, 128, 138, 140, 146

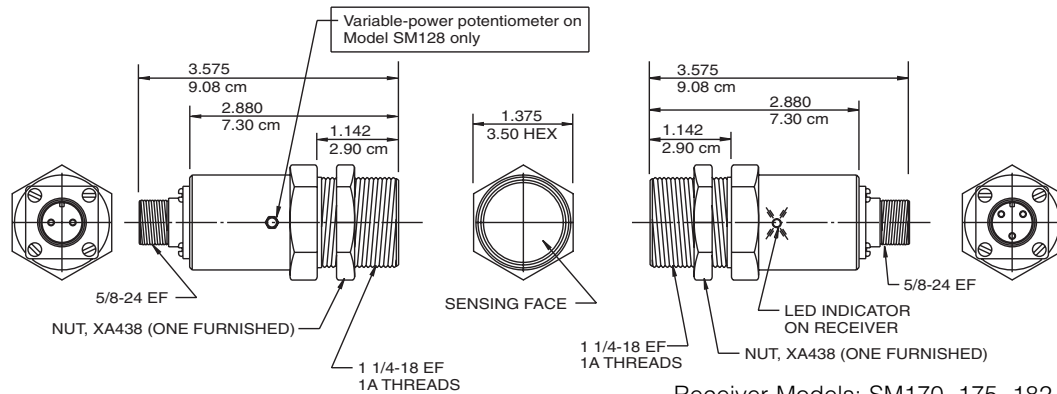

Receiver Models: SM170, 175, 182, 186, 188, 190, 193C, 194, 198C, 199C, 250

### Quick-disconnect (Watertight) Style

Transmitter Models: SM138WTC, 140WTC, 146WTC, 260WTC

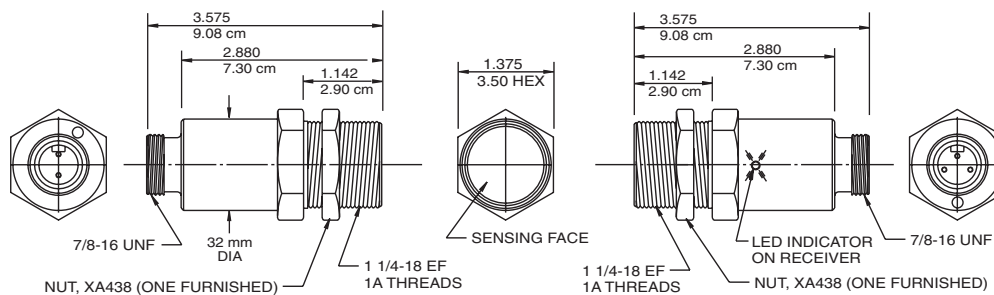

Receiver Models: SM186WTC, 190WTC, 250WTC, 252WTC, 256WTC

## Mounting Accessory

For all of the above transmitters and receivers.

### Model AC201 Sensor Mounting Bracket

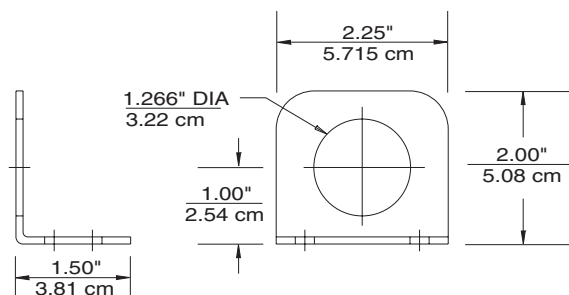

## General Specifications

### Sensing

Ranges:

381 mm (15"), 508 mm (20"), 635 mm (25"), 1016 mm (40"), 1829 mm (72")

Sonic Frequency: 180 kHz

Minimum-size Detection:

13 mm (0.5") at 381 mm (15") range  
13 mm (0.5") at 508 mm (20") range  
19 mm (0.75") at 635 mm (25") range  
19 mm (0.75") at 1016 mm (40") range  
25 mm (1.0") at 1829 mm (72") range  
Repeatability: 0.79 mm (0.031") typical

### Power Requirements

Supply Voltage:

12 to 24 VDC  $\pm$  10%, regulated supply

Current Consumption: 60 mA max.  
(excluding load) per set

Power Consumption: 1.2 W max.  
(excluding load) @ 15 VDC per set

### Output

NPN Sinking: 0 to 50 V, max.

Maximum on state voltage 100 mA @ 0.2 V

PNP Sourcing: 100 mA @ 24 VDC, max.

Receiver red LED "on" when beam is received

### Response Time

"On" 0.6 ms or 4 ms (model dependent - see selection chart)

"Off" 0.6 ms or 4 ms (model dependent - see selection chart)

### Indicators

Transmitter: None

Receiver:

Red LED: Illuminated when sonic energy is received, regardless of output state.

### Connections

Cable Style Models:

Transmitter:

305 cm (10'), 20 AWG, foil shield, lead-free, PVC jacket, 2-conductor

Receiver:

305 cm (10'), 22 AWG, foil shield, lead-free, PVC jacket, 3-conductor

Connector Style Models:

Amphenol (nonwatertight) quick-disconnect style Models:

Model AC100, Transmitter:

305 cm (10'), 20 AWG, foil shield, lead-free, PVC jacket, 2-conductor

Model AC150, Receiver:

305 cm (10'), 22 AWG, foil shield, lead-free, PVC jacket, 3-conductor

Watertight (WTC) quick-disconnect style models:

Model AC107, Transmitter:

7/8-16 mini, 4 m (12'), 18 AWG, 2-conductor

Model AC108, Receiver:

7/8-16 mini, 4 m (12'), 18 AWG, 3-conductor

### Protection

Power Supply: ESD

Outputs: ESD

### Environmental

Operating Temperature Range:

0° to 60°C

Storage Temperature Range: -40° to 100°C  
(-40° to 212°F)

Operating Humidity: 100%

Protection Ratings:

Cable Style: NEMA 4X, IP67

Amphenol quick-disconnect: NEMA 1

Watertight quick-disconnect: NEMA 4X, IP67

Chemical Resistance: Resists most acids and bases, including most food products. Polypropylene transducer face is available to provide resistance to corrosive chemicals, solvents, and steam.

### Construction

Housing:

Shock and vibration resistant

Case: stainless steel

Transducer Face: Buna rubber with sealed fiberglass, standard; Polypropylene transducer face available

Power Cable: Nontoxic PVC jacket

LED: Polycarbonate

## Accessories

**Model AC100**, 2-conductor, transmitter connector cable, 3 m (10'), for all SM100 series Amphenol connector-style transmitters

**Model AC107**, Straight, 7/8-16 mini, 2-pin, 2-conductor, mating connector cable, 4 m (12'), for all SM100 series, watertight, connector-style transmitters

**Model AC108**, Straight, 7/8-16 mini, 3-pin, 3-conductor, mating connector cable, 4 m (12'), for all SM100 series, watertight, connector-style receivers

**Model AC150**, 3-conductor, receiver connector cable, 3 m (10'), for all SM100 series Amphenol connector-style receivers

**Model AC160**, Cable grip for all cable-style, thru-beam sensors

**Model AC201**, Stainless, right-angle, single-thru-beam-sensor mounting bracket, slotted for adjustment

See page 7-1 for accessory photos.

# Transmitter Selection Chart

## SM100 Series MICROSONIC® Thru-Beam

Transmitter Model No.	Receiver Model No.	Power Version	Connection Style	NEMA Rating	Transmitter/Receiver Housing	Sensing Range	Remarks
SM120	SM170	15VDC	Quick Disconnect		Stainless	381mm(15")	Amphenol connector
	SM188	15VDC	Quick Disconnect		Stainless	508mm(20")	Amphenol connector
SM121	SM171	15VDC	305cm(10') Cable	4X, IP67	Stainless	381mm(15")	
	SM189	15VDC	305cm(10') Cable	4X, IP67	Stainless	508mm(20")	
SM125	SM175	24VDC	Quick Disconnect		Stainless	381mm(15")	Amphenol connector
	SM182	24VDC	Quick Disconnect		Stainless	381mm(15")	Amphenol connector
SM126	SM176	24VDC	305cm(10') Cable	4X, IP67	Stainless	381mm(15")	
SM128	SM186	12-24VDC	Quick Disconnect		Stainless	635mm(25")	Variable power, amphenol connector
	SM190	12-24VDC	Quick Disconnect		Stainless	381mm(15")	Variable power, amphenol connector
	SM250	12-24VDC	Quick Disconnect		Stainless	635mm(25")	Variable power, Amphenol connector
SM138	SM186	12-24VDC	Quick Disconnect		Stainless	1829mm(72")	High power, amphenol connector
	SM190	12-24VDC	Quick Disconnect		Stainless	1016mm(40")	High power, amphenol connector
	SM250	12-24VDC	Quick Disconnect		Stainless	1829mm(72")	High power, amphenol connector
SM138-WTC	SM186-WTC	12-24VDC	Quick Disconnect	4X, IP67	Stainless	1829mm(72")	High power, watertight connector
	SM190-WTC	12-24VDC	Quick Disconnect	4X, IP67	Stainless	1016mm(40")	High power, watertight connector
	SM250-WTC	12-24VDC	Quick Disconnect	4X, IP67	Stainless	1829mm(72")	High power, watertight connector
	SM252-WTC	12-24VDC	Quick Disconnect	4X, IP67	Stainless	1829mm(72")	High power, watertight connector
SM139	SM187	12-24VDC	305cm(10') Cable	4X, IP67	Stainless	1829mm(72")	High power
	SM191	12-24VDC	305cm(10') Cable	4X, IP67	Stainless	1016mm(40")	High power
	SM193	12-24VDC	305cm(10') Cable	4X, IP67	Stainless	1016mm(40")	High power
	SM195	12-24VDC	305cm(10') Cable	4X, IP67	Stainless	1016mm(40")	High power
	SM198	12-24VDC	305cm(10') Cable	4X, IP67	Stainless	1016mm(40")	High power
	SM199	12-24VDC	305cm(10') Cable	4X, IP67	Stainless	1016mm(40")	High power
	SM251	12-24VDC	305cm(10') Cable	4X, IP67	Stainless	1829mm(72")	High power
SM140•	SM186	12-24VDC	Quick Disconnect		Stainless	635mm(25")	Amphenol connector
	SM190	12-24VDC	Quick Disconnect		Stainless	381mm(15")	Amphenol connector
	SM193C	12-24VDC	Quick Disconnect		Stainless	381mm(15")	Amphenol connector
	SM194	12-24VDC	Quick Disconnect		Stainless	381mm(15")	Amphenol connector
	SM198C	12-24VDC	Quick Disconnect		Stainless	381mm(15")	Amphenol connector
	SM199C	12-24VDC	Quick Disconnect		Stainless	381mm(15")	Amphenol connector
	SM250	12-24VDC	Quick Disconnect		Stainless	635mm(25")	Amphenol connector
SM140-WTC	SM186-WTC	12-24VDC	Quick Disconnect	4X, IP67	Stainless	635mm(25")	Watertight connector
	SM190-WTC	12-24VDC	Quick Disconnect	4X, IP67	Stainless	381mm(15")	Watertight connector
	SM250-WTC	12-24VDC	Quick Disconnect	4X, IP67	Stainless	635mm(25")	Watertight connector
	SM252-WTC	12-24VDC	Quick Disconnect	4X, IP67	Stainless	635mm(25")	Watertight connector
SM141•	SM187	12-24VDC	305cm(10') Cable	4X, IP67	Stainless	635mm(25")	
	SM191	12-24VDC	305cm(10') Cable	4X, IP67	Stainless	381mm(15")	
	SM193	12-24VDC	305cm(10') Cable	4X, IP67	Stainless	381mm(15")	
	SM195	12-24VDC	305cm(10') Cable	4X, IP67	Stainless	381mm(15")	
	SM198	12-24VDC	305cm(10') Cable	4X, IP67	Stainless	381mm(15")	
	SM199	12-24VDC	305cm(10') Cable	4X, IP67	Stainless	381mm(15")	
	SM251	12-24VDC	305cm(10') Cable	4X, IP67	Stainless	635mm(25")	
SM145	SM187	12-24VDC	305cm(10') Cable	4X, IP67	Stainless	635mm(25")	
	SM191	12-24VDC	305cm(10') Cable	4X, IP67	Stainless	381mm(15")	
	SM193	12-24VDC	305cm(10') Cable	4X, IP67	Stainless	381mm(15")	
	SM195	12-24VDC	305cm(10') Cable	4X, IP67	Stainless	381mm(15")	
	SM198	12-24VDC	305cm(10') Cable	4X, IP67	Stainless	381mm(15")	
	SM199	12-24VDC	305cm(10') Cable	4X, IP67	Stainless	381mm(15")	
	SM251	12-24VDC	305cm(10') Cable	4X, IP67	Stainless	635mm(25")	
SM146	SM186	12-24VDC	Quick Disconnect		Stainless	1016mm (40")	Amphenol connector
	SM190	12-24VDC	Quick Disconnect		Stainless	635mm(25")	Amphenol connector
	SM193C	12-24VDC	Quick Disconnect		Stainless	635mm(25")	Amphenol connector
	SM194	12-24VDC	Quick Disconnect		Stainless	635mm(25")	Amphenol connector
	SM198C	12-24VDC	Quick Disconnect		Stainless	635mm(25")	Amphenol connector
	SM199C	12-24VDC	Quick Disconnect		Stainless	635mm(25")	Amphenol connector
	SM250	12-24VDC	Quick Disconnect		Stainless	1016mm (40")	Amphenol connector

# Transmitter Selection Chart

## SM100 Series (cont.) MICROSONIC® Thru-Beam

Transmitter Model No.	Receiver Model No.	Power Version	Connection Style	NEMA Rating	Transmitter/Receiver Housing	Sensing Range	Remarks
SM147	SM187	12-24VDC	305cm(10') Cable	4X, IP67	Stainless	1016mm (40")	
	SM191	12-24VDC	305cm(10') Cable	4X, IP67	Stainless	635mm(25")	
	SM193	12-24VDC	305cm(10') Cable	4X, IP67	Stainless	635mm(25")	
	SM195	12-24VDC	305cm(10') Cable	4X, IP67	Stainless	635mm(25")	
	SM198	12-24VDC	305cm(10') Cable	4X, IP67	Stainless	635mm(25")	
	SM199	12-24VDC	305cm(10') Cable	4X, IP67	Stainless	635mm(25")	
	SM251	12-24VDC	305cm(10') Cable	4X, IP67	Stainless	1016mm (40")	
	CS101	12-24VDC	305cm(10') Cable	4X, IP67	Stainless	1016mm (40")	Receiver has polypropylene coupler

• = Most commonly stocked sensors  
 All possible sensor configurations are not listed here.

# Receiver Selection Chart

## SM100 Series (cont.) MICROSONIC® Thru-Beam

Receiver Model No.	Transmitter Model No.	Power Version	Connection Style	NEMA Rating	Transmitter/Receiver Housing	Sensing Range	Response time	Remarks (Outputs N.O. unless noted)
SM170	SM120	15VDC	Quick Disconnect		Stainless	381mm(15")	On 4ms, Off 4ms	NPN/ Pull-up Res./Amphenol connector
SM171	SM121	15VDC	305cm(10') Cable	4X, IP67	Stainless	381mm(15")	On 4ms, Off 4ms	NPN/Pull-up Res.
SM175	SM125	24VDC	Quick Disconnect		Stainless	381mm(15")	On 4ms, Off 4ms	NPN/Pull-up Res./Amphenol connector
SM176	SM126	24VDC	305cm(10') Cable	4X, IP67	Stainless	381mm(15")	On 4ms, Off 4ms	NPN/Pull-up Res.
SM182	SM125	24VDC	Quick Disconnect		Stainless	381mm(15")	On 1ms, Off 1ms	NPN/Pull-up Res./Amphenol connector
SM186	SM128	12-24VDC	Quick Disconnect		Stainless	635mm(25")	On 4ms, Off 4ms	NPN sinking, amphenol connector
	SM138	12-24VDC	Quick Disconnect		Stainless	1829mm(72")	On 4ms, Off 4ms	NPN sinking, amphenol connector
	SM140	12-24VDC	Quick Disconnect		Stainless	635mm(25")	On 4ms, Off 4ms	NPN sinking, amphenol connector
	SM146	12-24VDC	Quick Disconnect		Stainless	1016mm(40")	On 4ms, Off 4ms	NPN sinking, amphenol connector
SM186-WTC	SM138-WTC	12-24VDC	Quick Disconnect	4X, IP67	Stainless	1829mm(72")	On 4ms, Off 4ms	NPN sinking, watertight connector
	SM140-WTC	12-24VDC	Quick Disconnect	4X, IP67	Stainless	635mm(25")	On 4ms, Off 4ms	NPN sinking, watertight connector
	SM146-WTC	12-24VDC	Quick Disconnect	4X, IP67	Stainless	1016mm(40")	On 4ms, Off 4ms	NPN sinking, watertight connector
SM187	SM139	12-24VDC	305cm(10') Cable	4X, IP67	Stainless	1829mm(72")	On 4ms, Off 4ms	NPN sinking
	SM141	12-24VDC	305cm(10') Cable	4X, IP67	Stainless	635mm(25")	On 4ms, Off 4ms	NPN sinking
	SM145	12-24VDC	305cm(10') Cable	4X, IP67	Stainless	635mm(25")	On 4ms, Off 4ms	NPN sinking
	SM147	12-24VDC	305cm(10') Cable	4X, IP67	Stainless	1016mm(40")	On 4ms, Off 4ms	NPN sinking
SM188	SM120	15VDC	Quick Disconnect		Stainless	508mm(20")	On 4ms, Off 4ms	NPN/ Pull-up Res./ Amphenol connector
SM189	SM121	15VDC	305cm(10') Cable	4X, IP67	Stainless	508mm(20")	On 4ms, Off 4ms	NPN/Pull-up Res.
SM190•	SM128	12-24VDC	Quick Disconnect		Stainless	381mm(15")	On 4ms, Off 4ms	NPN sinking, amphenol connector
	SM138	12-24VDC	Quick Disconnect		Stainless	1016mm(40")	On 4ms, Off 4ms	NPN sinking, amphenol connector
	SM140	12-24VDC	Quick Disconnect		Stainless	381mm(15")	On 4ms, Off 4ms	NPN sinking, amphenol connector
	SM146	12-24VDC	Quick Disconnect		Stainless	635mm(25")	On 4ms, Off 4ms	NPN sinking, amphenol connector
SM190-WTC	SM138-WTC	12-24VDC	Quick Disconnect	4X, IP67	Stainless	1016mm(40")	On 4ms, Off 4ms	NPN sinking, watertight connector
	SM140-WTC	12-24VDC	Quick Disconnect	4X, IP67	Stainless	381mm(15")	On 4ms, Off 4ms	NPN sinking, watertight connector
	SM146-WTC	12-24VDC	Quick Disconnect	4X, IP67	Stainless	635mm(25")	On 4ms, Off 4ms	NPN sinking, watertight connector
SM191•	SM139	12-24VDC	305cm(10') Cable	4X, IP67	Stainless	1016mm(40")	On 4ms, Off 4ms	NPN sinking
	SM141	12-24VDC	305cm(10') Cable	4X, IP67	Stainless	381mm(15")	On 4ms, Off 4ms	NPN sinking
	SM145	12-24VDC	305cm(10') Cable	4X, IP67	Stainless	381mm(15")	On 4ms, Off 4ms	NPN sinking
	SM147	12-24VDC	305cm(10') Cable	4X, IP67	Stainless	635mm(25")	On 4ms, Off 4ms	NPN sinking
SM193	SM139	12-24VDC	305cm(10') Cable	4X, IP67	Stainless	1016mm(40")	On 4ms, Off 4ms	PNP sourcing
	SM141	12-24VDC	305cm(10') Cable	4X, IP67	Stainless	381mm(15")	On 4ms, Off 4ms	PNP sourcing
	SM145	12-24VDC	305cm(10') Cable	4X, IP67	Stainless	381mm(15")	On 4ms, Off 4ms	PNP sourcing
	SM147	12-24VDC	305cm(10') Cable	4X, IP67	Stainless	635mm(25")	On 4ms, Off 4ms	PNP sourcing
SM193C	SM140	12-24VDC	Quick Disconnect		Stainless	381mm(15")	On 4ms, Off 4ms	PNP sourcing, amphenol connector
	SM146	12-24VDC	Quick Disconnect		Stainless	635mm(25")	On 4ms, Off 4ms	PNP sourcing, amphenol connector
SM194	SM140	12-24VDC	Quick Disconnect		Stainless	381mm(15")	On .6ms, Off .6ms	NPN sinking, amphenol connector
	SM146	12-24VDC	Quick Disconnect		Stainless	635mm(25")	On .6ms, Off .6ms	NPN sinking, amphenol connector
SM195	SM139	12-24VDC	305cm(10') Cable	4X, IP67	Stainless	1016mm(40")	On .6ms, Off .6ms	NPN sinking
	SM141	12-24VDC	305cm(10') Cable	4X, IP67	Stainless	381mm(15")	On .6ms, Off .6ms	NPN sinking
	SM145	12-24VDC	305cm(10') Cable	4X, IP67	Stainless	381mm(15")	On .6ms, Off .6ms	NPN sinking
	SM147	12-24VDC	305cm(10') Cable	4X, IP67	Stainless	635mm(25")	On .6ms, Off .6ms	NPN sinking
SM198	SM139	12-24VDC	305cm(10') Cable	4X, IP67	Stainless	1016mm(40")	On 4ms, Off 4ms	NPN sinking, no LED, with test point
	SM141	12-24VDC	305cm(10') Cable	4X, IP67	Stainless	381mm(15")	On 4ms, Off 4ms	NPN sinking, no LED, with test point
	SM145	12-24VDC	305cm(10') Cable	4X, IP67	Stainless	381mm(15")	On 4ms, Off 4ms	NPN sinking, no LED, with test point
	SM147	12-24VDC	305cm(10') Cable	4X, IP67	Stainless	635mm(25")	On 4ms, Off 4ms	NPN sinking, no LED, with test point
SM198C	SM140	12-24VDC	Quick Disconnect		Stainless	381mm(15")	On 4ms, Off 4ms	NPN sinking, no LED, with test point, amphenol connector
	SM146	12-24VDC	Quick Disconnect		Stainless	635mm(25")	On 4ms, Off 4ms	NPN sinking, no LED, with test point, amphenol connector
SM199	SM139	12-24VDC	305cm(10') Cable	4X, IP67	Stainless	1016mm(40")	On .6ms, Off .6ms	PNP sourcing
	SM141	12-24VDC	305cm(10') Cable	4X, IP67	Stainless	381mm(15")	On .6ms, Off .6ms	PNP sourcing
	SM145	12-24VDC	305cm(10') Cable	4X, IP67	Stainless	381mm(15")	On .6ms, Off .6ms	PNP sourcing
	SM147	12-24VDC	305cm(10') Cable	4X, IP67	Stainless	635mm(25")	On .6ms, Off .6ms	PNP sourcing
SM199C	SM140	12-24VDC	Quick Disconnect		Stainless	381mm(15")	On .6ms, Off .6ms	PNP sourcing, amphenol connector
	SM146	12-24VDC	Quick Disconnect		Stainless	635mm(25")	On .6ms, Off .6ms	PNP sourcing, amphenol connector
SM250	SM128	12-24VDC	Quick Disconnect		Stainless	635mm(25")	On 4ms, Off 4ms	PNP sourcing, amphenol connector
	SM138	12-24VDC	Quick Disconnect		Stainless	1829mm(72")	On 4ms, Off 4ms	PNP sourcing, amphenol connector
	SM140	12-24VDC	Quick Disconnect		Stainless	635mm(25")	On 4ms, Off 4ms	PNP sourcing, amphenol connector
	SM146	12-24VDC	Quick Disconnect		Stainless	1016mm(40")	On 4ms, Off 4ms	PNP sourcing, amphenol connector
SM250-WTC	SM138-WTC	12-24VDC	Quick Disconnect	4X, IP67	Stainless	1829mm(72")	On 4ms, Off 4ms	PNP sourcing, watertight connector
	SM140-WTC	12-24VDC	Quick Disconnect	4X, IP67	Stainless	635mm(25")	On 4ms, Off 4ms	PNP sourcing, watertight connector
	SM146-WTC	12-24VDC	Quick Disconnect	4X, IP67	Stainless	1016mm(40")	On 4ms, Off 4ms	PNP sourcing, watertight connector
SM251	SM139	12-24VDC	305cm(10') Cable	4X, IP67	Stainless	1829mm(72")	On 4ms, Off 4ms	PNP sourcing
	SM141	12-24VDC	305cm(10') Cable	4X, IP67	Stainless	635mm(25")	On 4ms, Off 4ms	PNP sourcing
	SM145	12-24VDC	305cm(10') Cable	4X, IP67	Stainless	635mm(25")	On 4ms, Off 4ms	PNP sourcing
	SM147	12-24VDC	305cm(10') Cable	4X, IP67	Stainless	1016mm(40")	On 4ms, Off 4ms	PNP sourcing



# Receiver Selection Chart

## SM100 Series (cont.) MICROSONIC® Thru-Beam

Receiver Model No.	Transmitter Model No.	Power Version	Connection Style	NEMA Rating	Transmitter/Receiver Housing	Sensing Range	Response time	Remarks (Outputs N.O. unless noted)
SM252-WTC	SM138-WTC	12-24VDC	Quick Disconnect	4X, IP67	Stainless	1829mm(72")	On 4ms, Off 4ms	NPN sinking, N.C., watertight connector
	SM140-WTC	12-24VDC	Quick Disconnect	4X, IP67	Stainless	635mm(25")	On 4ms, Off 4ms	NPN sinking, N.C., watertight connector
	SM146-WTC	12-24VDC	Quick Disconnect	4X, IP67	Stainless	1016mm(40")	On 4ms, Off 4ms	NPN sinking, N.C., watertight connector
CS101	SM147	12-24VDC	305cm(10') Cable	4X, IP67	Stainless	1016mm(40")	On 4ms, Off 4ms	PNP sourcing, polypropylene coupler

• = Most commonly stocked sensors  
 All possible sensor configurations are not listed here.

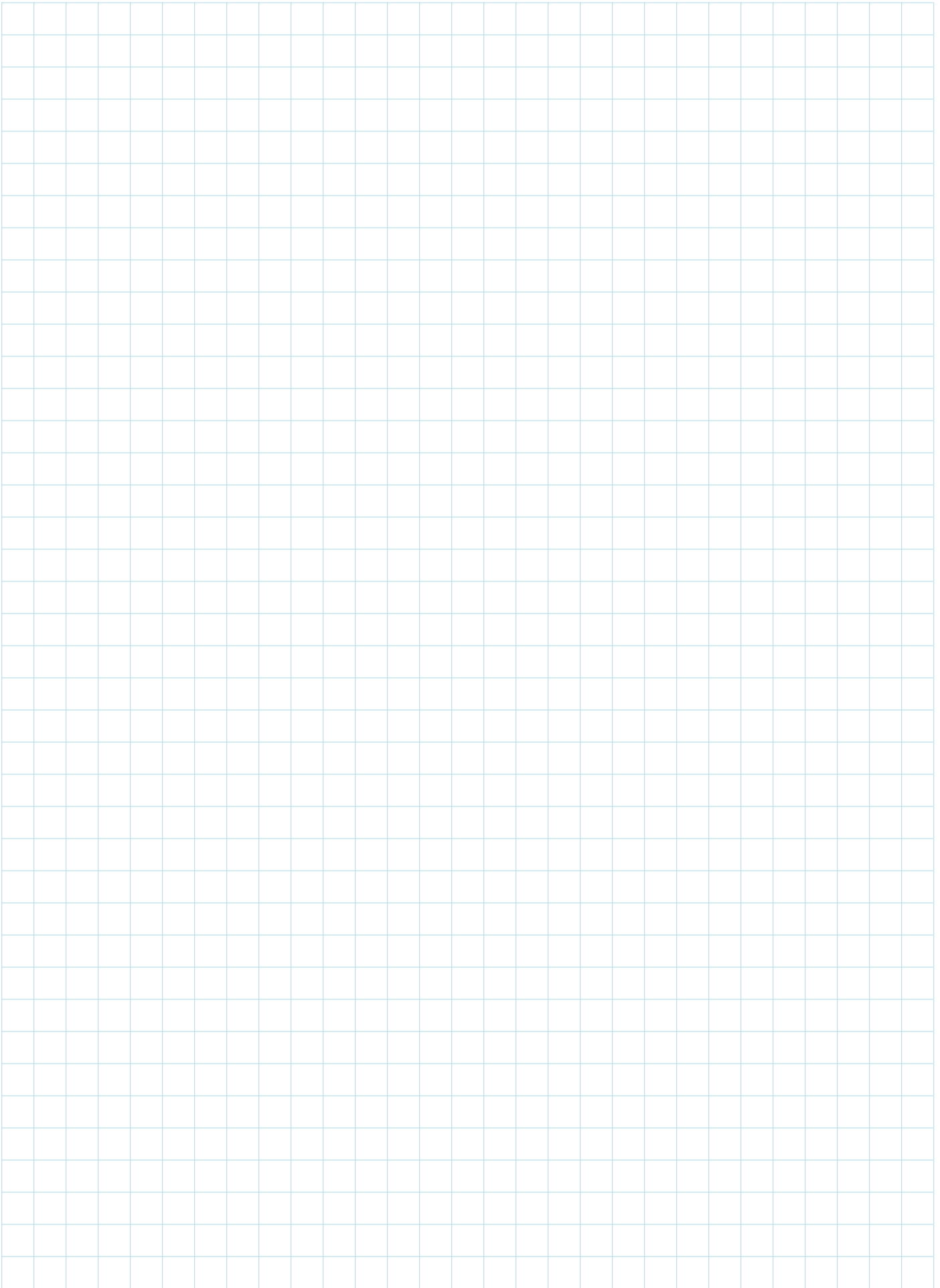

## MICROSONIC® Miniature Thru-beam Sensors



### **Extremely reliable thru-beam sensing in an extremely small package with a range up to 203 mm (8")**

The miniature SM400 series is powerful in sensing capability and employs the same reliable, world-leading ultrasonic technology built into the original MICROSONIC® SM100 series. The SM400 series of thru-beam sensors is available in FDA-rated ULTEM® plastic flat-profile and 12 mm threaded barrel housings designed for small object applications where installation space is limited. An extremely reliable "across-the-line" sensing capability of up to 205 mm (8") is possible with this miniature thru-beam sensor series.

The MICROSONIC® SM400 thru-beam sensors are ideal for detecting small objects of any color or material, transparent or opaque, regular or irregular shaped, as well as those with either poor reflective or fully sound-absorbing surfaces. An output response time of 4 ms allows for the detection of objects moving at speeds of over 2000 units per minute. "Smart" sensor enhancements include solid-state sink and source outputs in normally open or

closed configurations.

With protection ratings of NEMA 4X and IP67, these CE certified sensors are resistant to dust, 100% humidity, most acids and bases, and high-pressure washdowns that often times leave water buildup on the sensing face. Unlike photoelectrics, these miniature thru-beam sensors are virtually unaffected by splashing food, caustic cleaning solutions, and changing light conditions or colors. Shielding and filtering make the fully encapsulated sensors highly immune to radiated or conducted energy. The sensors are also tolerant of high noise levels and vibration with an operating temperature range of -20° to 70°C. 12 to 24 VDC circuitry with sinking (NPN) and sourcing (PNP) outputs makes these sensors directly compatible with most programmable logic controllers, computers, and other logic control systems. Available in both a cable and two connector styles (micro or pico), the receiver units have a dual color LED status indicator. An orange illumination indicates when sonic energy is being received from the transmitter. An amber illumination indicates when the sonic energy is not being received from the transmitter due to a blocking

- *Ideal for small object detection*
- *Sensing ranges up to 203 mm (8")*
- *Available in 12mm barrel or flat-profile housings*
- *Ideal for limited space installations*
- *CE certified*

object or a misalignment between the two sensors.

Rugged, robust, and easy to set up, these sensors need no maintenance and require no sensitivity adjustments to compensate for inconsistent product materials.

The SM400 series is a cost-effective solution for a wide variety of leading-edge, trailing-edge and gap sensing applications, no matter the color of the object or material, whether clear or opaque, where repeatable and reliable performance is a day in and day out requirement. Some applications include small clear plastic or glass container detection; web registration hole or notch detection; web edge guide detection of plastic film, cellophane, photographic film, metallic foils, paper, textile fabrics, and many more.

## Operation

The MICROSONIC® SM400 series sensors are continuous-wave devices that consist of a high frequency transmitter and receiver positioned opposite each other, illustrated at right, at a distance of up to 205 mm (8"). During operation, the transmitter sends a continuous ultrasonic beam which is picked up by the receiver. When an object of any material or shape passes between the transmitter and receiver and breaks the beam, object presence is detected and the output of the receiver switches. Or, when a hole allows the beam to pass through to the receiver, the output of the receiver also switches.

The thru-beam sensing mode is set up by mounting the sensors on the same axis opposite each other as shown in Figure 1.

Positioning of the transmitter and receiver is extremely important for the reliable detection of objects, particularly small ones. As the figure also shows, the width of the transmitted sound beam initially expands at a rate of 10 degrees (5 degrees each side of the common axis) for the 500 kHz models as the distance between the transmitter and receiver increases. If the object is too small, it is possible for the beam to "wrap around" the object enough to prevent the output from switching, as shown in Figure 2.

Reliable detection of 13 mm wide (0.5") or smaller objects is achieved when the objects pass near the face of either the transmitter or receiver. An alternative approach is to position the transmitter and receiver on parallel axes, as shown in Figure 3, so as to reduce the amount of beam reaching the receiver. Even in harsh, messy environments, MICROSONIC® thru-beam sensors maintain their full range where other sensor types fail.

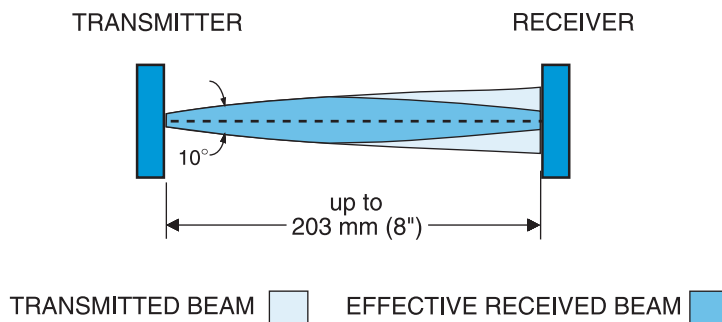
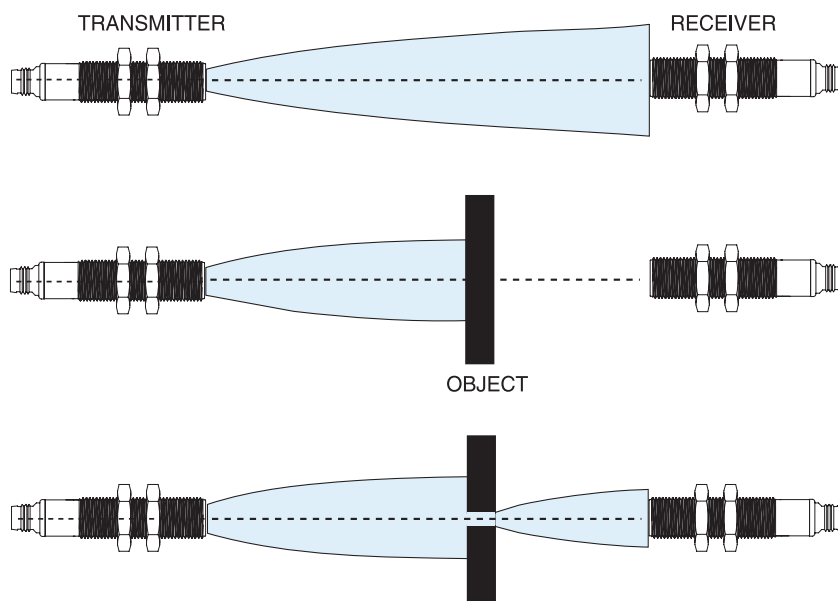

Figure 1

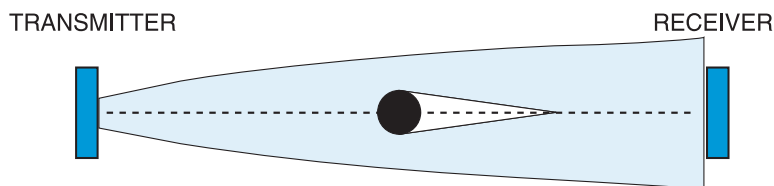

Figure 2

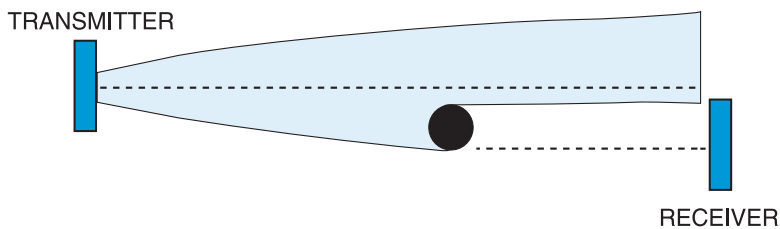

Figure 3

## Mounting

The Model SM400 series sensors should be mounted in brackets that allow them to be adjusted for proper alignment on the same axis. Hyde Park offers the following mounting accessories:

**Flat-profile:** Model AC246 small right-angle stainless mounting bracket; Model AC247 stainless and polyamide conveyor-rail clamp/bracket (illustrated with dimensions on Page 5-20).

**12mm barrel:** Model AC235 small right-angle stainless mounting bracket; Model AC236 stainless and polyamide conveyor-rail clamp/bracket; Model AC237 straight stainless mounting bracket (illustrated with dimensions on Page 5-20).

## Electrical Wiring

### Transmitters

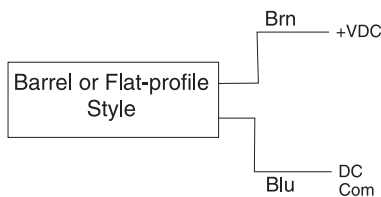

### Receivers

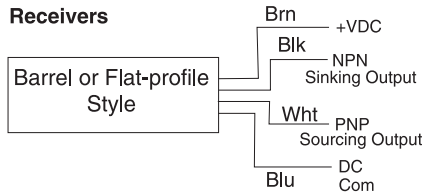

## Model Reference Guide - SM400 Series

Use the guide below to ensure the correct model number is specified for the application. Please note that not all sensor model combinations are available.

### EXAMPLE MODEL:

**SM4 0 1 A - 08 - 00 FP**

### MICROSONIC® Product Series

### Power/Connection Type

- 0...12 to 24 VDC / Cable style
- 3...12 to 24 VDC / 3-pin "PICO" connector w/PNP output
- 4...12 to 24 VDC / 3-pin "PICO" connector w/NPN output
- 5...12 to 24 VDC / 4-pin "PICO" connector
- 6...12 to 24 VDC / 4-pin "PICO" connector – output pins reversed
- 8...12 to 24 VDC / 4-pin "MICRO" connector
- 9...12 to 24 VDC / 4-pin "MICRO" connector – output pins reversed

Flat-Profile sensors with either connector and Threaded Barrel sensors with a "Micro" connector have a 152 mm (6") pigtail

### Sensing Function

- 0...Transmitter
- 1...Receiver

### Design Level

- A...Applies to all models

### Sensing Range

- 04...Low-power: 102 mm (4")\*
- 08...Standard: 203 mm (8")

### Sensing Variations - Transmitter

- 00...Standard

### Sensing Variations - Receiver\*\*\*

- 00...N.O. Output, 4 ms on & off
- 01...N.O. Fast response, 0.4 ms on & off
- 10...N.C. Output, 4 ms on & off
- 11...N.C. Output, fast response, 0.4 ms on & off

### Housing Types

- ...No letter indicates standard ULTEM®\*\* plastic - 12 mm barrel housing
- FP...ULTEM®\*\* flat-profile housing

### Power Cable Length

- /nn...Cable lengths other than 10 feet, cable style only

\* Used to detect narrow objects

\*\* ULTEM® is a registered trademark of the General Electric Company.

\*\*\* N.O. – "Normally Open" when object breaks the beam

N.C. – "Normally Closed" when object breaks the beam

## Receiver Outputs

### NPN Sinking and PNP Sourcing

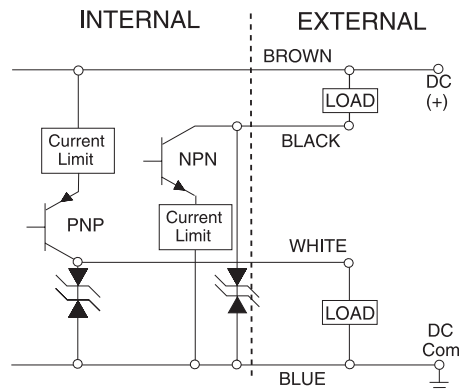

## Receiver Outputs

### Transmitter Connector Pins

#### SM430, SM440

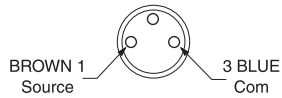

Note: Sensor view-pico connector (pigtail for flat-profile)

#### SM450

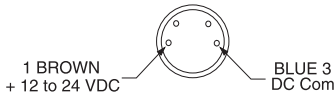

Note: Sensor view-pico connector (pigtail for flat-profile)

#### SM480

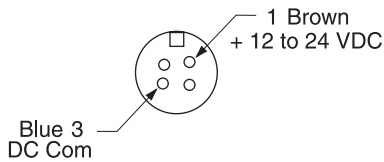

Note: Sensor view-micro connector (pigtail for flat-profile)

### Receiver Connector Pins

#### SM430, SM440

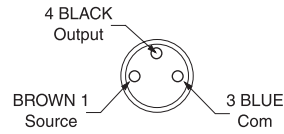

Note: Sensor view-pico connector (pigtail for flat-profile)

#### SM450

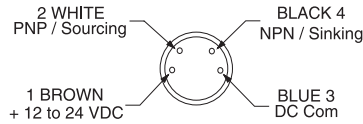

Note: Sensor view-pico connector (pigtail for flat-profile)

#### SM480

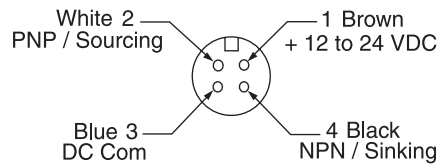

Note: Sensor view-micro connector (pigtail for flat-profile)

FOR ALL SM400 PRODUCTS  
LED color change has been implemented  
Current LED  
Orange  
Amber  
New LED  
Amber  
Green

## Dimensions

**Barrel Cable Style**  
(ULTEM® plastic)

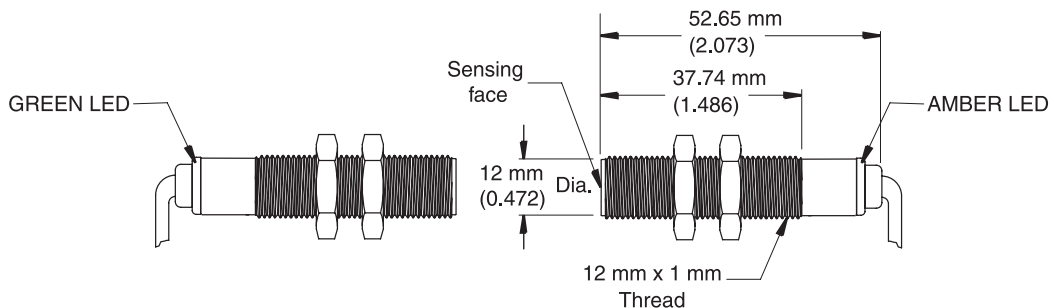

Transmitter Models:  
SM400A-XXX-XX

Receiver Models:  
SM401A-XXX-XX

## Dimensions

### Barrel Connector Style

(ULTEM® plastic)

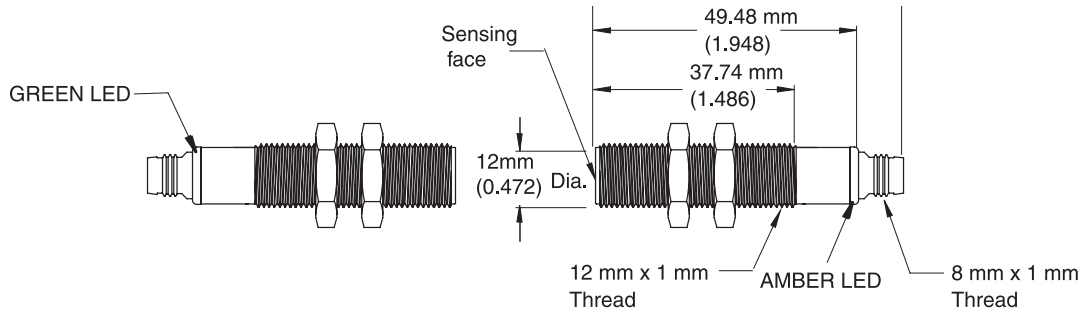

Transmitter Models:  
SM430-, SM440-, SM450A-XXX-XX

Receiver Models:  
SM431-, SM441-, SM451A-XXX-XX

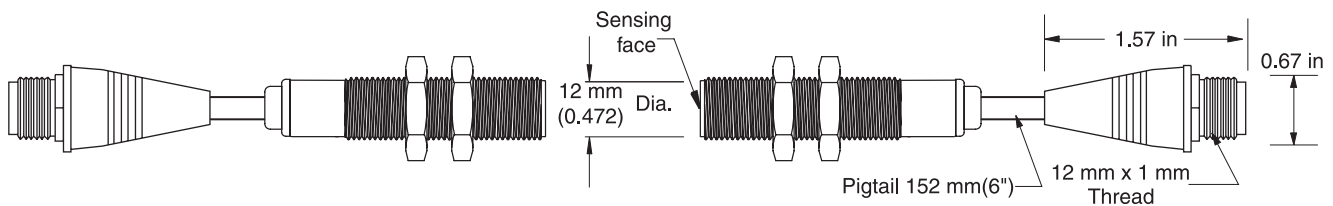
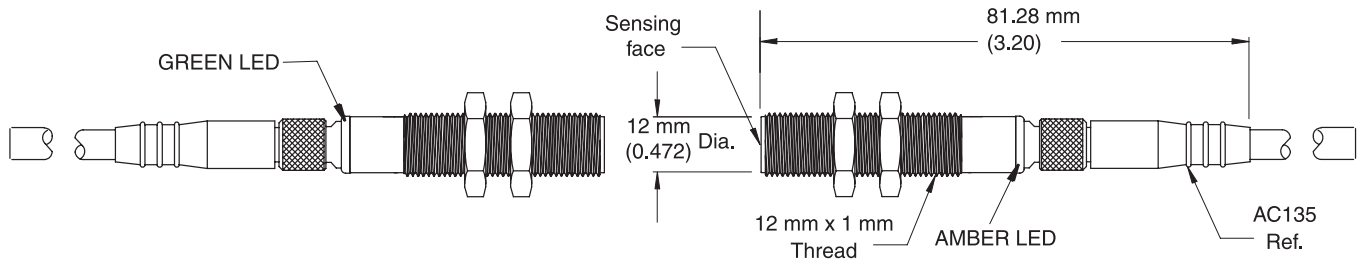
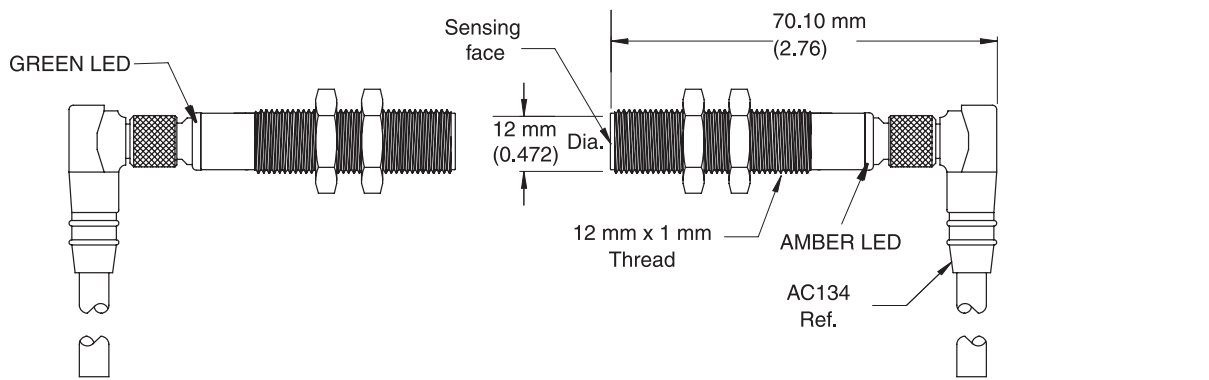

Transmitter Models:  
SM480A-XXX-XX

Receiver Models:  
SM481A-XXX-XX

MICROSONIC® SM400  
SERIES

## Dimensions

### Flat-Profile Cable/Connector Style

(ULTEM® plastic)

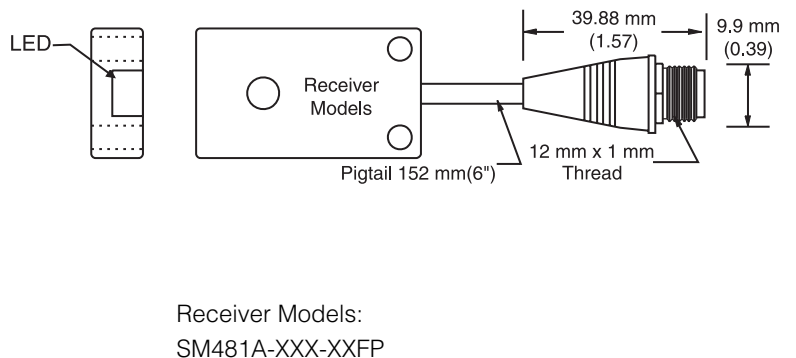
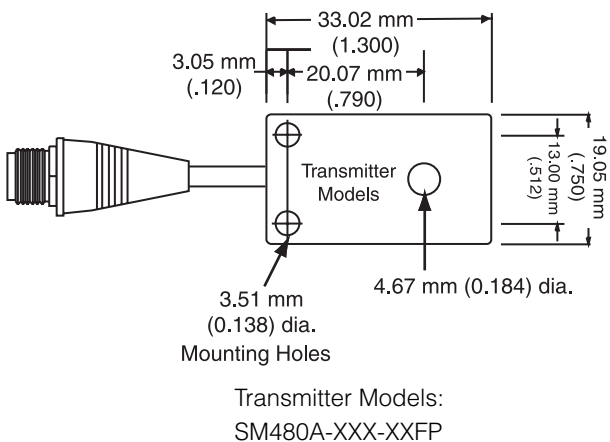
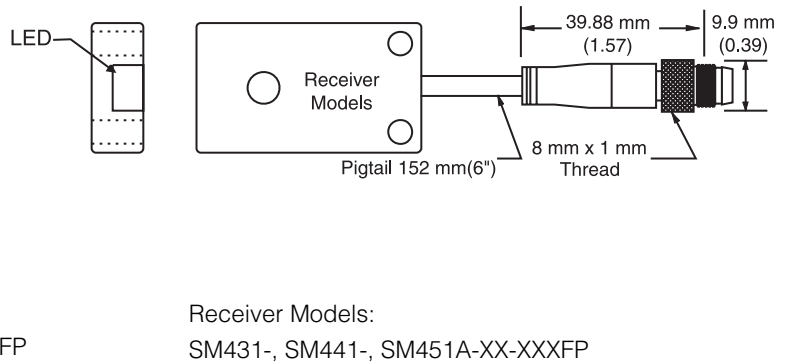
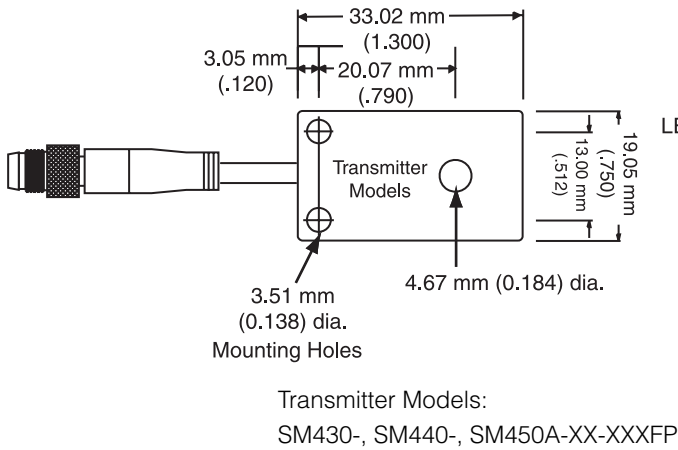
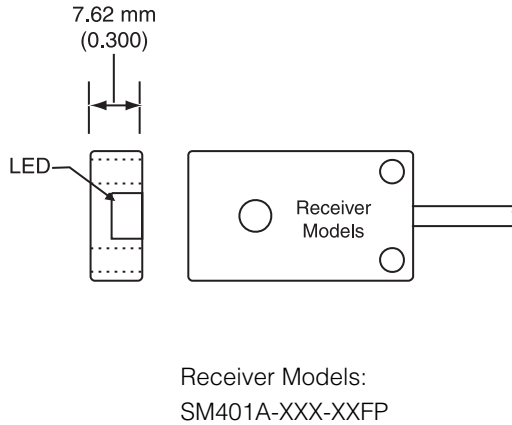
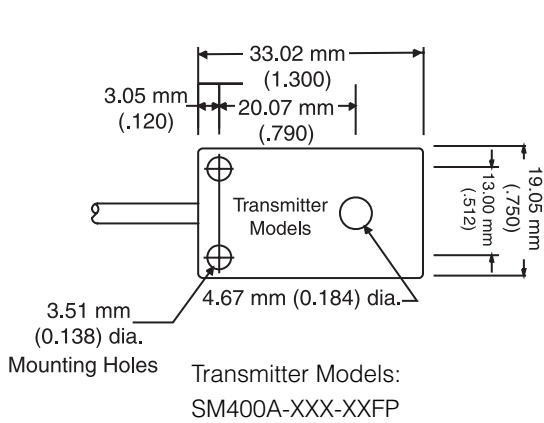
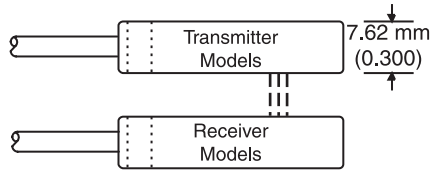



## Accessories

**AC130** Straight, M12 micro, 4-conductor, connector/cable assembly, 5 m (16') (for barrel and flat-profile micro sensors)

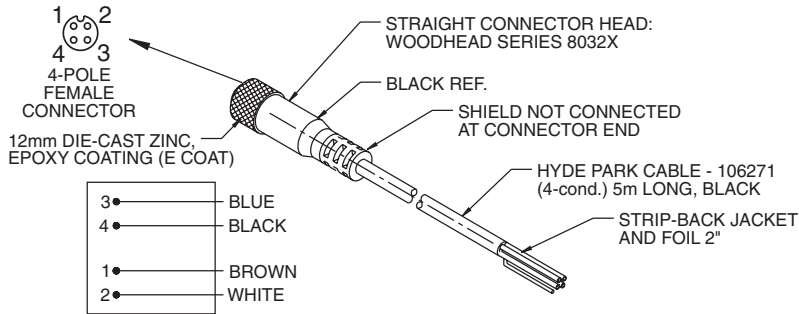

### AC134

Right-angle, M8 pico, 4 conductor cable/connector assembly, 5m (16').

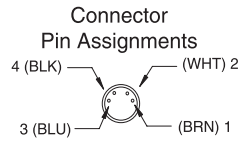
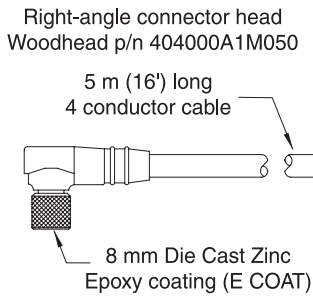

### AC135

Straight, M8 pico, 4 conductor cable/connector assembly, 5m (16').

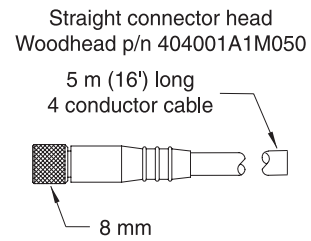

### AC141

Right-angle, M8 pico, 3 conductor cable/connector assembly, 5m (16') - (for barrel connector-style sensors)

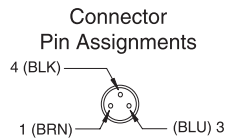
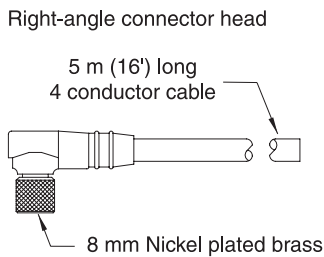

### AC142

Straight, M8 pico, 3 conductor cable/connector assembly, 5m (16') - (for barrel connector-style sensors)

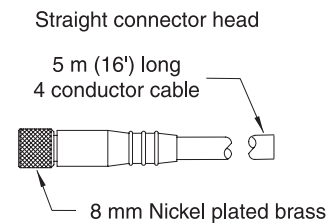

**AC235**

Right-angle, stainless, mounting bracket  
(for 12 mm barrel sensors)

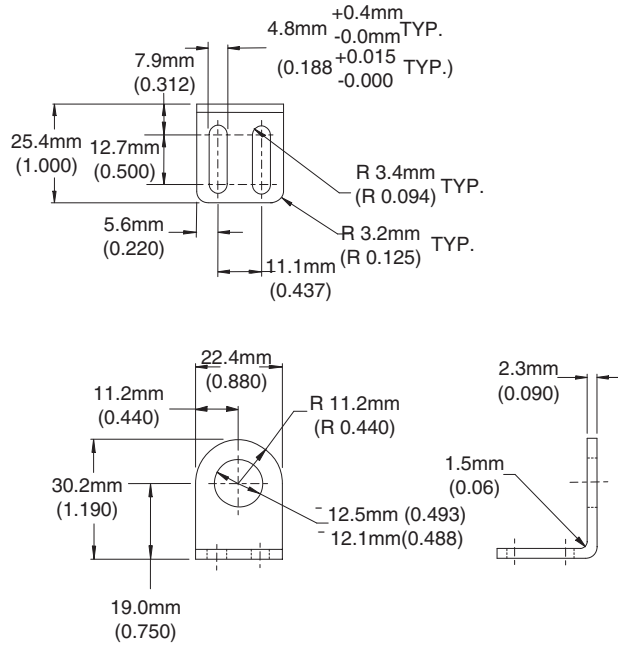

**AC237**

Straight, stainless, mounting bracket  
(for 12 mm barrel sensors)

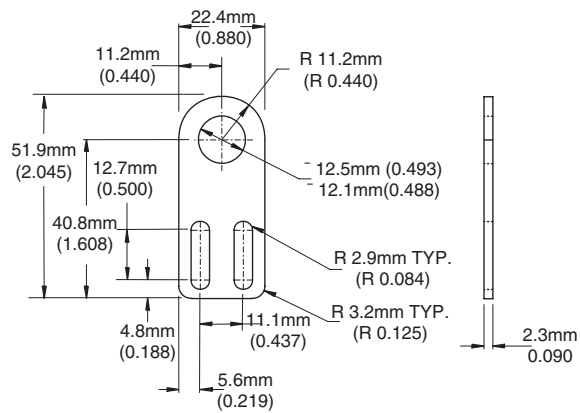

**AC247**

Stainless and polyamide  
conveyor-rail clamp/bracket set  
(for Flat-Profile sensor)

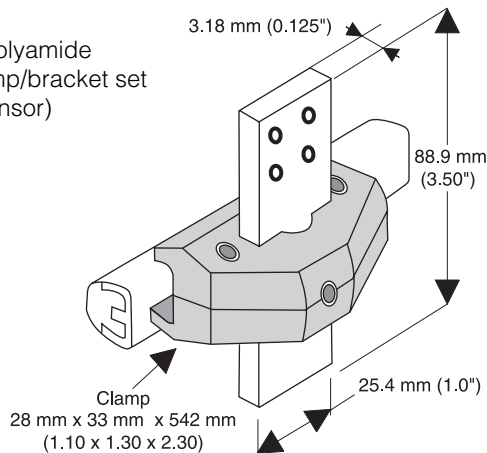

**AC236**

Stainless and polyamide conveyor-rail clamp/  
bracket set (for 12mm barrel sensor)

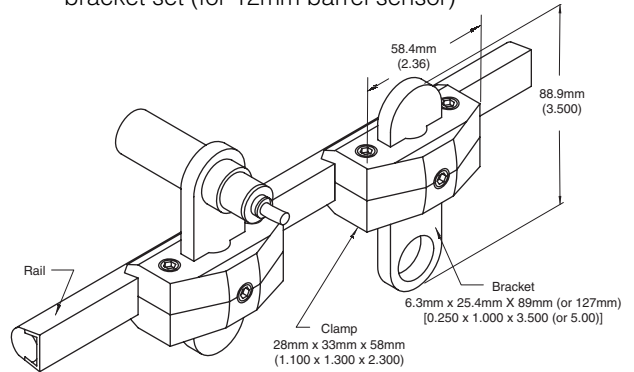

**AC246**

Stainless and polyamide conveyor-rail  
clamp/bracket set (for Flat-Profile sensor)

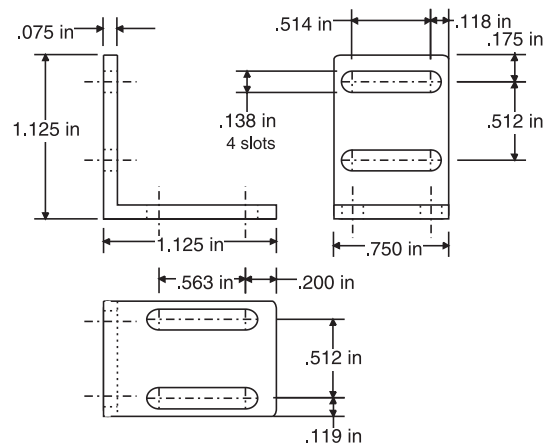

## General Specifications

### Sensing

- Ranges:
  - 102 mm (4.0"), 204 mm (8.0")
- Sonic Frequency: 500 kHz
- Minimum-size Detection:
  - 12.2 mm (0.50") at 102 mm (4.0") range
  - 25.4 mm (1.0") at 204 mm (8.0") range
- Repeatability:
  - 0.79mm (0.031") typical

### Power Requirements

- Supply Voltage:
  - 12VDC to 24VDC  $\pm$  10%, regulated supply
- Current Consumption:
  - 50 mA per set max.
- Power Consumption:
  - 1.2 W max. @ 24 VDC per set

### Output

- Sinking Output (NPN):
  - Maximum on-state voltage: 0.75 V @ 100 mA
  - Maximum load current: 100 mA
  - Maximum applied voltage: 30 VDC
- Sourcing Output (PNP):
  - Maximum on-state voltage drop: 1.10 V @ 100mA
  - Maximum load current: 100mA
  - Output voltage:  $V_{Supply} - 1.10 V @ 100mA$

### Response Time

- "On" 0.4 ms or 4 ms  
(Model dependent - see selection chart)
- "Off" 0.4 ms or 4 ms  
(Model dependent - see selection chart)

### Indicators

- Transmitter: Green
- Receiver:
  - Orange LED: Illuminated when sonic energy is received, regardless of output state
  - Amber LED: Indicates sonic beam is blocked

### Connections

- Transmitter cable style model SM400 series:
  - 28 AWG, foil shield, lead-free, PVC jacket
  - 2-conductor, 3M (10') long
- Transmitter connector style model SM450 series:
  - Flat-profile pigtail 150 mm (6.0") long
  - pico-connector
- Transmitter connector style model SM480 series:
  - Flat-profile pigtail 150 mm (6.0") long
  - pico-connector
- Receiver cable style model SM401 series:
  - 28 AWG, foil shield, lead-free, PVC jacket
  - 4-conductor, 3M (10') long
- Receiver connector style model SM451 series:
  - Barrel style pico-connector
  - Flat-profile pigtail 150 mm (6.0") long
  - pico-connector
- Receiver connector style model SM481 series:
  - Flat-profile pigtail 150 mm (6.0") long
  - pico-connector

### Protection

- Power Supply: Current-limited over-voltage, ESD, reverse polarity
- Outputs: Current-limited over-voltage, ESD, over-current

### Environmental

- Operating Temperature Range:
  - 20° to 65°C (-4° to 136°F) @ 24V supply
  - 20° to 70°C (-4° to 144°F) @ 20V supply
- Storage Temperature Range:
  - 40° to 100°C (-40° to 212°F)
- Operating Humidity: 100%
- Protection Ratings:
  - Cable Style: NEMA 4X, IP67
  - Watertight "micro" quick-disconnect: NEMA 4X, IP67
- Chemical Resistance: Resists most acids and bases, including most food products.

### Agency Approvals

- EMC: EN 61326:1997 (industrial including amendment A1:1998)
- Safety: En 61010-1
- Declaration of Conformity available upon request*

### Construction

- Case (barrel and flat-profile types):
  - ULTEM<sup>®</sup> plastic (FDA Approved)
- Transducer Face: Epoxy
- Sensor Cables: Lead-free, PVC jacketed, black
- LED lens: Polycarbonate

\* ULTEM<sup>®</sup> is a registered trademark of The General Electric Co.

## Accessories

- Model AC118**, Right-angle, M12 micro, 4-pin, 2-conductor, connector/cable assembly, 5 m (16'), for SM480 series micro connector transmitters
- Model AC128**, Straight, M12 micro, 4-pin, 2-conductor, connector/cable assembly, 5 m (16'), for SM480 series micro connector transmitters
- Model AC130**, Straight, M12 micro, 4-conductor, connector/cable assembly, 5 m (16'), for SM481 micro connector receivers
- Model AC134**, Right-angle, M8 pico, 4-conductor, connector/cable assembly, 5m (16') for SM350 and SM451 series sensors
- Model AC135**, Straight, M8 pico, 4-conductor, connector/ cable assembly, 5m (16') for SM350 and SM451 series sensors
- Model AC137**, Pico-to-micro pigtail adapter cable for barrel connector-style sensors
- Model AC138**, Pico-to-micro pigtail adapter cable, output pins reversed for barrel connector-style sensors

- Model AC141**, Right-angle, M8 pico, 3-conductor pico connector/cable assembly, 5 m (16') for SM431 connector-style receivers
- Model AC142**, Straight, M8 pico, 3-conductor pico connector/cable assembly, 5 m (16') for SM431 connector-style receivers
- Model AC143**, Right-angle, M8 pico, 3-pin, 2-conductor connector/cable assembly, 5 m (16') for SM430 connector-style transmitters (same housing as AC141)
- Model AC144**, Straight, M8 pico, 3-pin, 2-conductor connector/cable assembly, 5 m (16') for SM430 connector-style transmitters (same housing as AC142)
- Model AC145**, Right-angle, M8 pico, 4-pin, 2-conductor connector/cable assembly, 5 m (16') for SM450 connector-style transmitters (same housing as AC134)
- Model AC146**, Straight, M8 pico, 4-pin, 2-conductor connector/cable assembly, 5 m (16') for SM450 connector-style transmitters (same housing as AC135)
- Model AC235**, Right-angle stainless mounting bracket for barrel connector-style sensors
- Model AC236**, Stainless and polyamide conveyor-rail clamp/bracket set for barrel connector-style sensors
- Model AC237**, Straight stainless mounting bracket for barrel connector-style sensors
- Model AC246**, Right-angle, stainless, mounting bracket for flat-profile style sensors
- Model AC247**, Stainless and polyamide conveyor-rail clamp/bracket set for flat-profile style sensors

See page 7-1 for accessory photos.

# Selection Chart

## SM400 Series MICROSONIC® Thru-Beam

Transmitter	Model No.	Power Version	Connection Style	Sensing Range	Materials		Transmitter		Sensing Variations			
					Housing	Flat-profile	Standard	Standard	Receiver			
									Fast Response .4ms on & off	N.C. Output	N.C. Output Fast Response	
SM400A-04-00	SM401A-04-00	12-24VDC	10' cable	4"	■		■	■				
SM400A-04-00FP	SM401A-04-00FP	12-24VDC	10' cable	4"	■	■	■	■				
SM400A-04-00	SM401A-04-01	12-24VDC	10' cable	4"	■		■		■			
SM400A-04-00FP	SM401A-04-01FP	12-24VDC	10' cable	4"	■	■	■		■			
SM400A-04-00	SM401A-04-10	12-24VDC	10' cable	4"	■		■			■		
SM400A-04-00FP	SM401A-04-10FP	12-24VDC	10' cable	4"	■	■	■			■		
SM400A-04-00	SM401A-04-11	12-24VDC	10' cable	4"	■		■				■	
SM400A-04-00FP	SM401A-04-11FP	12-24VDC	10' cable	4"	■	■	■				■	
SM400A-08-00	SM401A-08-00	12-24VDC	10' cable	8"	■		■	■				
SM400A-08-00FP	SM401A-08-00FP	12-24VDC	10' cable	8"	■	■	■	■				
SM400A-08-00	SM401A-08-01	12-24VDC	10' cable	8"	■		■		■			
SM400A-08-00FP	SM401A-08-01FP	12-24VDC	10' cable	8"	■	■	■		■			
SM400A-08-00	SM401A-08-10	12-24VDC	10' cable	8"	■		■			■		
SM400A-08-00FP	SM401A-08-10FP	12-24VDC	10' cable	8"	■	■	■			■		
SM400A-08-00	SM401A-08-11	12-24VDC	10' cable	8"	■		■				■	
SM400A-08-00FP	SM401A-08-11FP	12-24VDC	10' cable	8"	■	■	■				■	
SM430A-04-00	SM431A-04-00	12-24VDC	10' cable	4"	■		■	■				3-pin pico (8 mm) connector w/PNP output only
SM430A-04-00FP	SM431A-04-00FP	12-24VDC	10' cable	4"	■	■	■	■				3-pin pico (8 mm) connector w/PNP output only
SM430A-04-00	SM431A-04-01	12-24VDC	10' cable	4"	■		■		■			3-pin pico (8 mm) connector w/PNP output only
SM430A-04-00FP	SM431A-04-01FP	12-24VDC	10' cable	4"	■	■	■		■			3-pin pico (8 mm) connector w/PNP output only
SM430A-04-00	SM431A-04-10	12-24VDC	10' cable	4"	■		■			■		3-pin pico (8 mm) connector w/PNP output only
SM430A-04-00FP	SM431A-04-10FP	12-24VDC	10' cable	4"	■	■	■			■		3-pin pico (8 mm) connector w/PNP output only
SM430A-04-00	SM431A-04-11	12-24VDC	10' cable	4"	■		■				■	3-pin pico (8 mm) connector w/PNP output only
SM430A-04-00FP	SM431A-04-11FP	12-24VDC	10' cable	4"	■	■	■				■	3-pin pico (8 mm) connector w/PNP output only
SM430A-08-00	SM431A-08-00	12-24VDC	10' cable	8"	■		■	■				3-pin pico (8 mm) connector w/PNP output only
SM430A-08-00FP	SM431A-08-00FP	12-24VDC	10' cable	8"	■	■	■	■				3-pin pico (8 mm) connector w/PNP output only
SM430A-08-00	SM431A-08-01	12-24VDC	10' cable	8"	■		■		■			3-pin pico (8 mm) connector w/PNP output only
SM430A-08-00FP	SM431A-08-01FP	12-24VDC	10' cable	8"	■	■	■		■			3-pin pico (8 mm) connector w/PNP output only
SM430A-08-00	SM431A-08-10	12-24VDC	10' cable	8"	■		■			■		3-pin pico (8 mm) connector w/PNP output only
SM430A-08-00FP	SM431A-08-10FP	12-24VDC	10' cable	8"	■	■	■			■		3-pin pico (8 mm) connector w/PNP output only
SM430A-08-00	SM431A-08-11	12-24VDC	10' cable	8"	■		■				■	3-pin pico (8 mm) connector w/PNP output only
SM430A-08-00FP	SM431A-08-11FP	12-24VDC	10' cable	8"	■	■	■				■	3-pin pico (8 mm) connector w/PNP output only
SM440A-04-00	SM441A-04-00	12-24VDC	Pico	4"	■		■	■				3-pin pico (8 mm) connector w/NPN output only
SM440A-04-00FP	SM441A-04-00FP	12-24VDC	Pico	4"	■	■	■	■				3-pin pico (8 mm) connector w/NPN output only
SM440A-04-00	SM441A-04-01	12-24VDC	Pico	4"	■		■		■			3-pin pico (8 mm) connector w/NPN output only
SM440A-04-00FP	SM441A-04-01FP	12-24VDC	Pico	4"	■	■	■		■			3-pin pico (8 mm) connector w/NPN output only
SM440A-04-00	SM441A-04-10	12-24VDC	Pico	4"	■		■			■		3-pin pico (8 mm) connector w/NPN output only
SM440A-04-00FP	SM441A-04-10FP	12-24VDC	Pico	4"	■	■	■			■		3-pin pico (8 mm) connector w/NPN output only
SM440A-04-00	SM441A-04-11	12-24VDC	Pico	4"	■		■				■	3-pin pico (8 mm) connector w/NPN output only
SM440A-04-00FP	SM441A-04-11FP	12-24VDC	Pico	4"	■	■	■				■	3-pin pico (8 mm) connector w/NPN output only
SM440A-08-00	SM441A-08-00	12-24VDC	Pico	8"	■		■	■				3-pin pico (8 mm) connector w/NPN output only
SM440A-08-00FP	SM441A-08-00FP	12-24VDC	Pico	8"	■	■	■	■				3-pin pico (8 mm) connector w/NPN output only
SM440A-08-00	SM441A-08-01	12-24VDC	Pico	8"	■		■		■			3-pin pico (8 mm) connector w/NPN output only
SM440A-08-00FP	SM441A-08-01FP	12-24VDC	Pico	8"	■	■	■		■			3-pin pico (8 mm) connector w/NPN output only
SM440A-08-00	SM441A-08-10	12-24VDC	Pico	8"	■		■			■		3-pin pico (8 mm) connector w/NPN output only
SM440A-08-00FP	SM441A-08-10FP	12-24VDC	Pico	8"	■	■	■			■		3-pin pico (8 mm) connector w/NPN output only
SM440A-08-00	SM441A-08-11	12-24VDC	Pico	8"	■		■				■	3-pin pico (8 mm) connector w/NPN output only
SM440A-08-00FP	SM441A-08-11FP	12-24VDC	Pico	8"	■	■	■				■	3-pin pico (8 mm) connector w/NPN output only
SM450A-04-00	SM451A-04-00	12-24VDC	Pico	4"	■		■	■				4-pin pico (8 mm) connector
SM450A-04-00FP	SM451A-04-00FP	12-24VDC	Pico	4"	■	■	■	■				4-pin pico (8 mm) connector
SM450A-04-00	SM451A-04-01	12-24VDC	Pico	4"	■		■		■			4-pin pico (8 mm) connector
SM450A-04-00FP	SM451A-04-01FP	12-24VDC	Pico	4"	■	■	■		■			4-pin pico (8 mm) connector
SM450A-04-00	SM451A-04-10	12-24VDC	Pico	4"	■		■			■		4-pin pico (8 mm) connector
SM450A-04-00FP	SM451A-04-10FP	12-24VDC	Pico	4"	■	■	■			■		4-pin pico (8 mm) connector
SM450A-04-00	SM451A-04-11	12-24VDC	Pico	4"	■		■				■	4-pin pico (8 mm) connector
SM450A-04-00FP	SM451A-04-11FP	12-24VDC	Pico	4"	■	■	■				■	4-pin pico (8 mm) connector

All possible sensor configurations are not listed here.  
 Also available with 4-pin pico connectors, output pins reversed (SM460)  
 Also available with 4-pin micro connectors, output pins reversed (SM490)

# Selection Chart

## SM400 Series (cont.)

### MICROSONIC® Thru-Beam

Transmitter	Model No. Receiver	Power Version	Connection Style	Sensing Range	Materials		Transmitter		Sensing Variations				
					Housing	Flat-profile	Standard	Standard	Fast Response	Receiver	N.C. Output		N.C. Output Fast Response
					12mm				4ms On & Off				
SM450A-08-00	SM451A-08-00	12-24VDC	Pico	4"	■		■	■				4-pin pico (8 mm) connector	
SM450A-08-00FP	SM451A-08-00FP	12-24VDC	Pico	4"		■	■	■				4-pin pico (8 mm) connector	
SM450A-08-00	SM451A-08-01	12-24VDC	Pico	4"	■		■		■			4-pin pico (8 mm) connector	
SM450A-08-00FP	SM451A-08-01FP	12-24VDC	Pico	4"		■	■		■			4-pin pico (8 mm) connector	
SM450A-08-00	SM451A-08-10	12-24VDC	Pico	4"	■		■				■	4-pin pico (8 mm) connector	
SM450A-08-00FP	SM451A-08-10FP	12-24VDC	Pico	4"		■	■				■	4-pin pico (8 mm) connector	
SM450A-08-00	SM451A-08-11	12-24VDC	Pico	4"	■		■					■	4-pin pico (8 mm) connector
SM450A-08-00FP	SM451A-08-11FP	12-24VDC	Pico	4"		■	■					■	4-pin pico (8 mm) connector
SM480A-04-00	SM481A-04-00	12-24VDC	10' cable	8"	■		■	■					4-pin micro (12 mm) connector
SM480A-04-00FP	SM481A-04-00FP	12-24VDC	10' cable	8"		■	■	■					4-pin micro (12 mm) connector
SM480A-04-00	SM481A-04-01	12-24VDC	10' cable	8"	■		■		■				4-pin micro (12 mm) connector
SM480A-04-00FP	SM481A-04-01FP	12-24VDC	10' cable	8"		■	■		■				4-pin micro (12 mm) connector
SM480A-04-00	SM481A-04-10	12-24VDC	10' cable	8"	■		■				■		4-pin micro (12 mm) connector
SM480A-04-00FP	SM481A-04-10FP	12-24VDC	10' cable	8"		■	■				■		4-pin micro (12 mm) connector
SM480A-04-00	SM481A-04-11	12-24VDC	10' cable	8"	■		■					■	4-pin micro (12 mm) connector
SM480A-04-00FP	SM481A-04-11FP	12-24VDC	10' cable	8"		■	■					■	4-pin micro (12 mm) connector
SM480A-08-00	SM481A-08-00	12-24VDC	10' cable	8"	■		■	■					4-pin micro (12 mm) connector
SM480A-08-00FP	SM481A-08-00FP	12-24VDC	10' cable	8"		■	■	■					4-pin micro (12 mm) connector
SM480A-08-00	SM481A-08-01	12-24VDC	10' cable	8"	■		■		■				4-pin micro (12 mm) connector
SM480A-08-00FP	SM481A-08-01FP	12-24VDC	10' cable	8"		■	■		■				4-pin micro (12 mm) connector
SM480A-08-00	SM481A-08-10	12-24VDC	10' cable	8"	■		■				■		4-pin micro (12 mm) connector
SM480A-08-00FP	SM481A-08-10FP	12-24VDC	10' cable	8"		■	■				■		4-pin micro (12 mm) connector
SM480A-08-00	SM481A-08-11	12-24VDC	10' cable	8"	■		■					■	4-pin micro (12 mm) connector
SM480A-08-00FP	SM481A-08-11FP	12-24VDC	10' cable	8"		■	■					■	4-pin micro (12 mm) connector

All possible sensor configurations are not listed here.

Also available with 4-pin pico connectors, output pins reversed (SM460)

Also available with 4-pin micro connectors, output pins reversed (SM490)

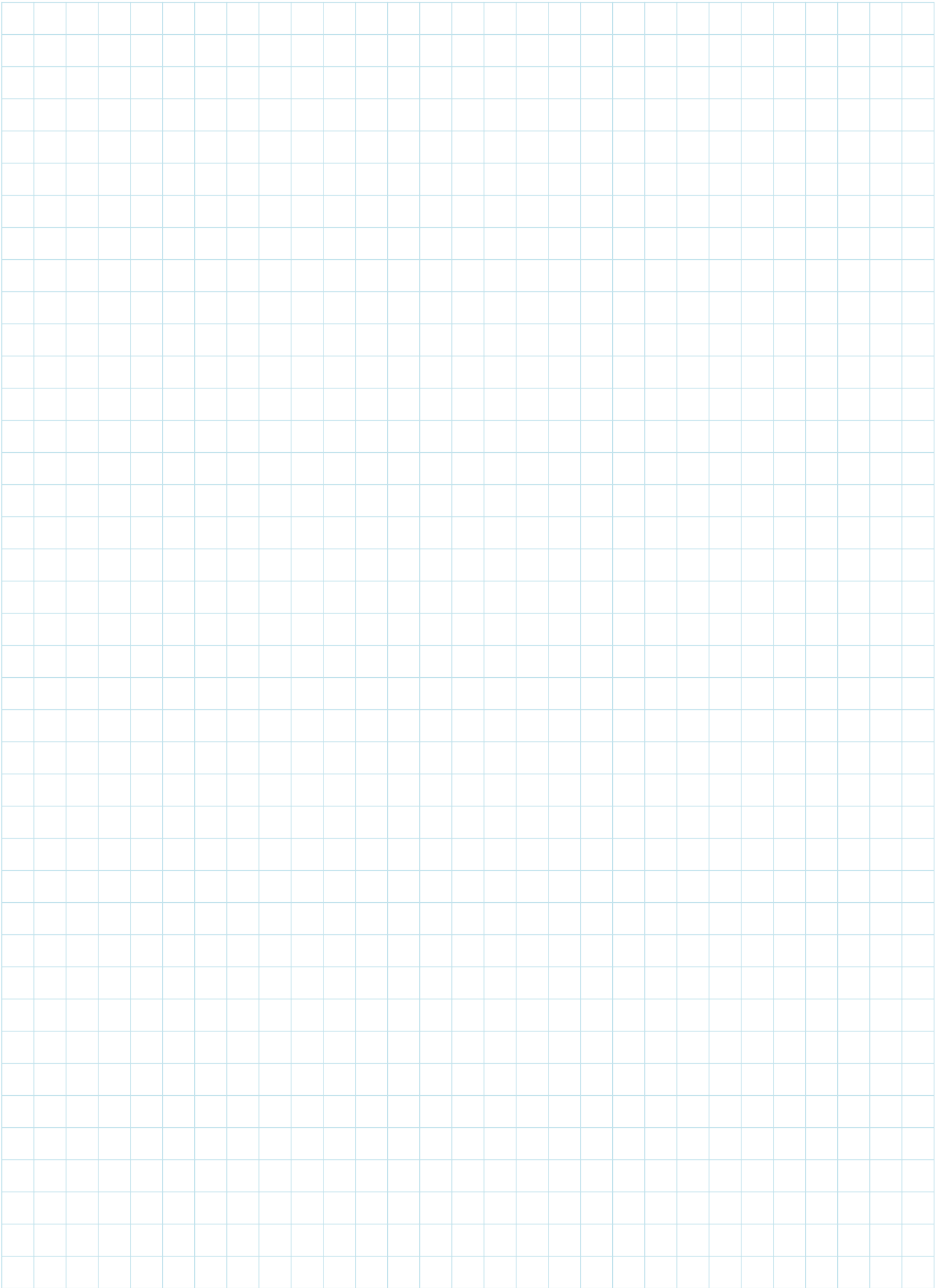

## MICROSONIC® Remote Thru-beam Sensors



### **MICROSONIC® remote ultrasonic sensors put precise, thru-beam sensing in hard-to-reach areas**

Utilizing the same world-leading ultrasonic sensing technology built into the SM100 series of MICROSONIC® thru-beam sensors, the SM700 series of remote thru-beam sensors takes the accurate detection of objects almost anywhere. Stainless steel armor cables, available in three different lengths, 508 mm (20"), 1016 mm (40") and 1270 mm (50"), link selected standard SM100 series thru-beam transmitters and receivers with the remote stainless steel probes. Designed for extremely tight areas where it is either difficult or impossible to mount and use the SM100 series sensors, these remote sensors have right-angle style probes to further facilitate thru-beam setup and operation.

Unlike photoelectrics, these stainless steel remote sensors are virtually unaffected by splashing food, caustic cleaning solutions, frequent high-pressure washdowns, humidity, changing light conditions or colors, dust, and ambient noise. The rugged sensors need no maintenance and require no sensitivity adjustments to compensate for inconsistent product materials.

Response times, ranging from 4 ms down to 0.6 ms, make the MICROSONIC® Model SM700 series of remote thru-beam sensors particularly effective in critical, high-speed, machine process applications. These applications include: double sheet (tissue) detection, film and web hole detection, lead-edge gating, edge-guide monitoring, and transparent object detection.

The 12 to 24 VDC circuitry and output signal make these sensors directly compatible with many programmable logic controllers, computers, and other logic control systems.

- *Ideal for limited spaces*
- *High repeatability and reliability*
- *Self contained*
- *Sensing range 381 mm (15")*
- *Meets NEMA 4X/ IP67 standards*

## Operation

The MICROSONIC® sensors are continuous-wave devices that consist of an ultra-high-frequency transmitter and receiver positioned opposite each other, illustrated at right, at a distance of up to 381 mm (15"). During operation, the transmitter sends a continuous ultrasonic beam which is picked up by the receiver. When an object of any material or shape passes between the transmitter and receiver and breaks the beam, object presence is detected and the output of the receiver switches.

With all circuitry compactly sealed in the stainless steel transmitter and receiver probes, the MICROSONIC® sensors boast a narrow, constant, high-frequency sonic beam for high sensing resolution.

The thru-beam sensing mode is set up by mounting the sensors on the same axis opposite each other as shown in Figure 1. The distance (range) between the transmitter face and receiver face can be up to 381 mm (15").

Positioning of the transmitter and receiver for operation is extremely important for the reliable detection of objects, particularly small ones. As the figure also shows, the width of the transmitted sound beam initially expands at a rate of 10 degrees (5 degrees each side of the common axis) as the distance between the transmitter and receiver increases. This means that, if the distance between the transmitter and receiver is too great and the object is too small, it is possible for the beam to "wrap around" the object enough to not cause the receiver output to switch, as shown in Figure 2.

Therefore, reliable detection of small objects is achieved when the objects are allowed to pass near the face of either the transmitter or receiver. This may also be achieved by moving the probes closer together as shown in Figure 3.

Where sensing distances are adversely affected as the environment becomes more contaminated, the MICROSONIC® sensors remain constant under adverse conditions where other sensor types fail.

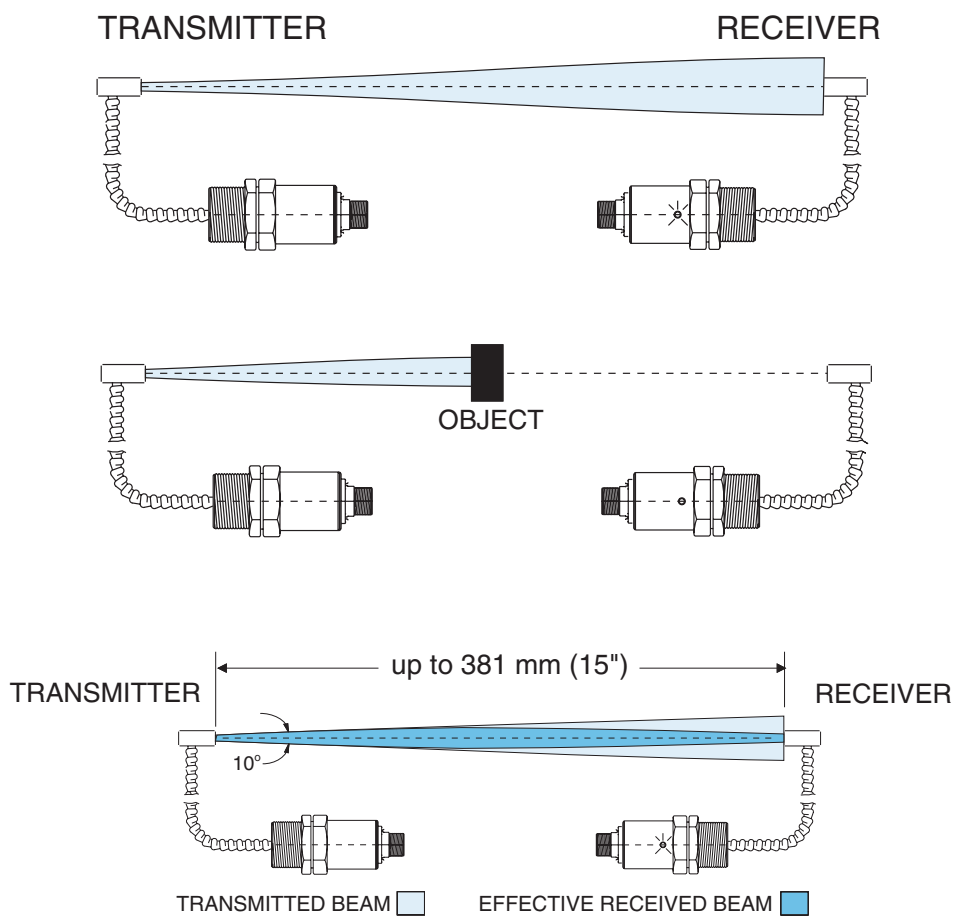

Figure 1, Thru-beam Pattern and Range

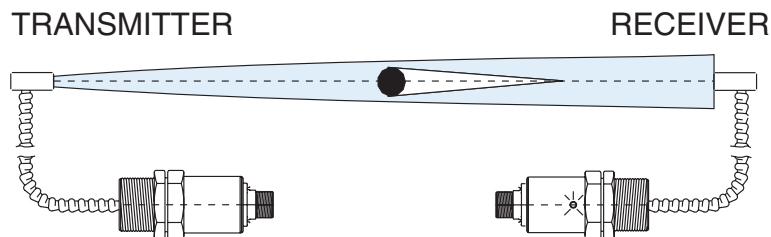

Figure 2

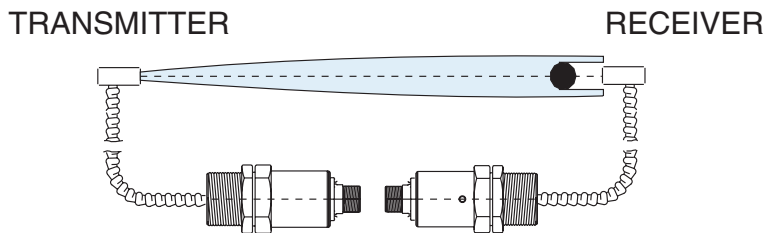

Figure 3



## Mounting Accessories

The Model SM700 series remote thru-beam sensors should be mounted in brackets that allow them to be adjusted for proper alignment on the same axis.

Hyde Park offers the Model AC201 stainless, right-angle, single-thru-beam-sensor, mounting bracket and the Model AC213 stainless and Teflon, remote sensing probe mounting bracket which are illustrated, with dimensions, on Page 5-28.

## Electrical Wiring

### Cable Style

Remote Transmitter Models, Standard Cable Length 3 m (10')

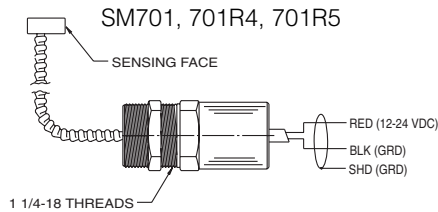

Remote Receiver Models, Standard Cable Length 3 m (10')

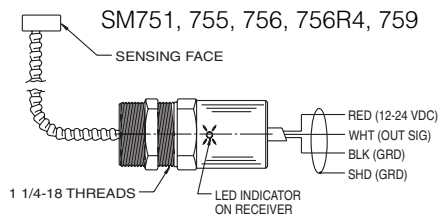

### Quick-disconnect (Amphenol) Style\*

Remote Transmitter Models with Model AC100 Amphenol, 2-conductor, 3 m (10') Mating Connector Cable:

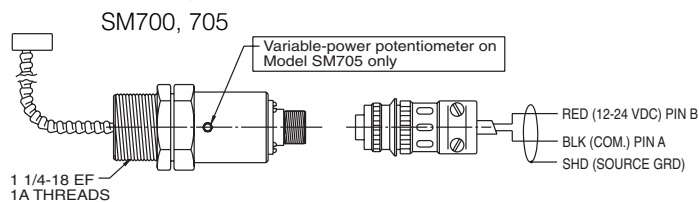

Remote Receiver Models with Model AC150 Amphenol, 3-conductor, 3 m (10') Mating Connector Cable:

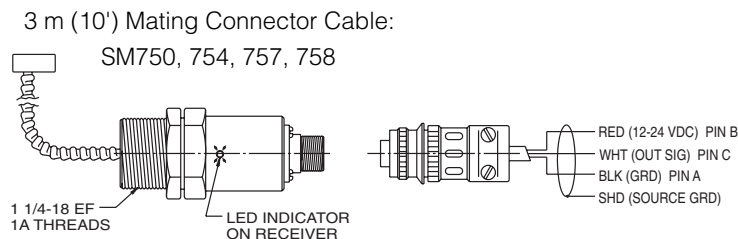

\* Use Belden Cable No. 8423 and No. 9154 to extend receiver and transmitter cable length, respectively. Maximum recommended cable length is 152 m (500").

### Quick-disconnect (Watertight) Style

Remote Transmitter Models with Model AC107, 7/8-16 mini, 2-conductor, 4 m (12') Mating Connector Cable  
SM700WTC, 705WTC

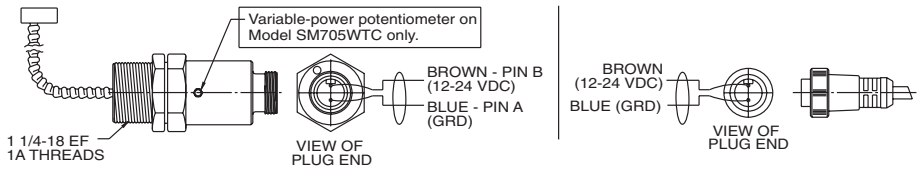

Remote Receiver Models and Model AC108, 7/8-16 mini, 3-conductor, 4 m (12') Mating Connector Cable  
SM750WTC

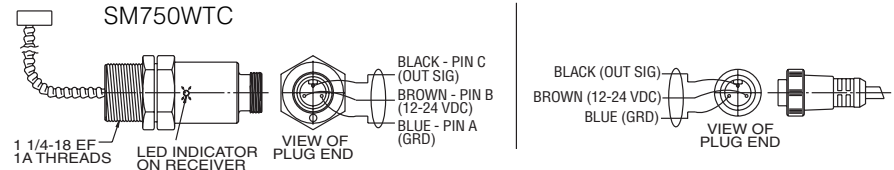

## Receiver Outputs

### NPN SINKING\*

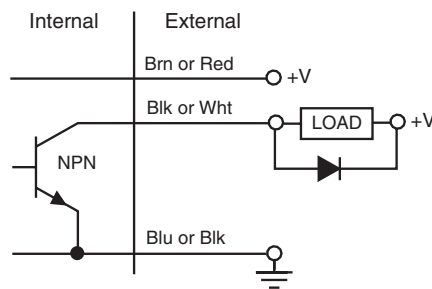

### PNP SOURCING\*

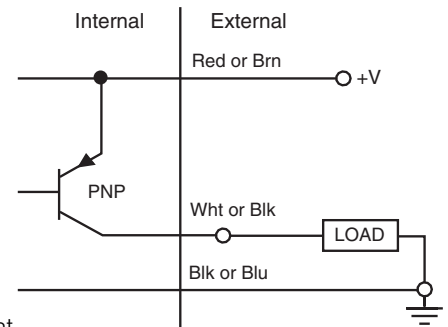

\* Cable conductor colors vary, dependent upon the sensor model number.

## Dimensions

### Cable Style

Remote Transmitter Models: SM701, 701R4, 701R5

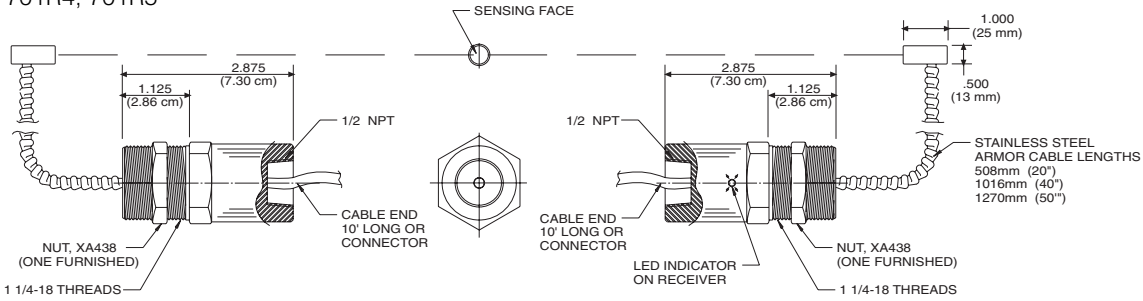

Remote Receiver Models: SM751, 755, 756, 756R4, 759

### Quick-disconnect (Amphenol) Style

Remote Transmitter Models: SM700, 705

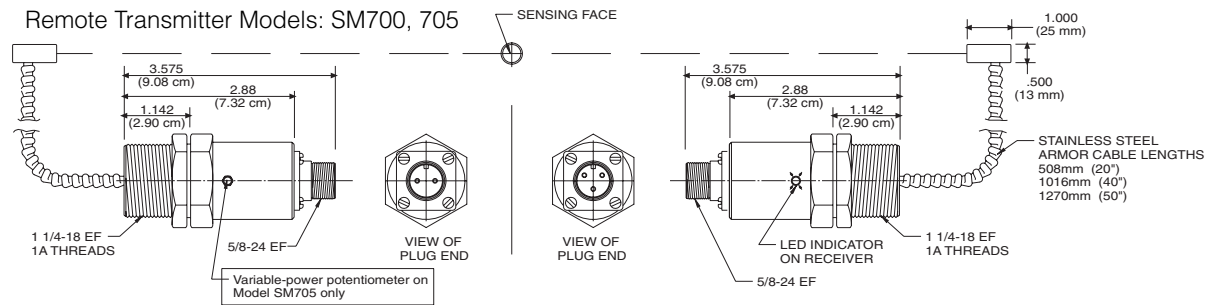

Remote Receiver Models: SM750, 754, 757, 758

### Quick-disconnect (Watertight) Style

Remote Transmitter Models: SM700WTC, 705WTC

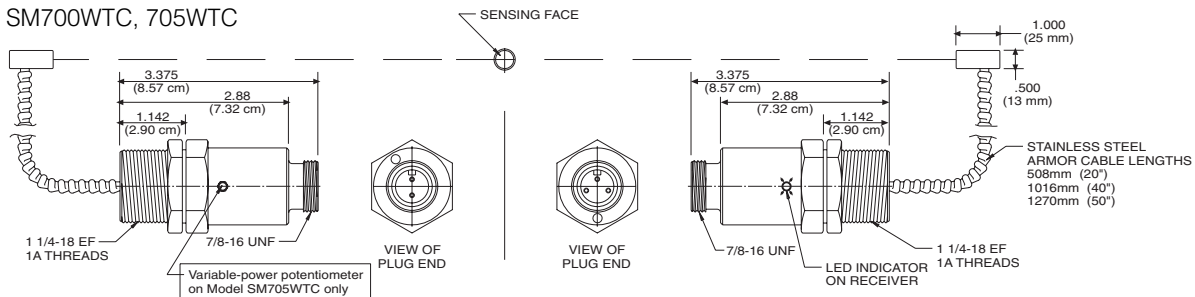

Remote Receiver Model: SM750WTC

## Mounting Accessories

**Model AC201**, Stainless, right-angle, single-thru-beam-sensor, mounting bracket, slotted for adjustment

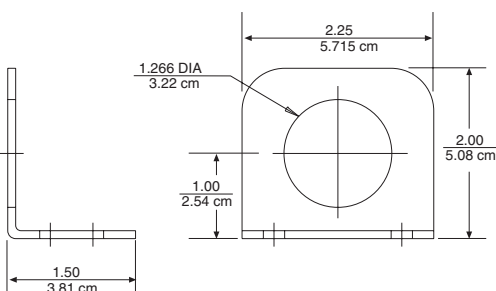

**Model AC213**, Stainless and Teflon, remote sensing probe mounting bracket

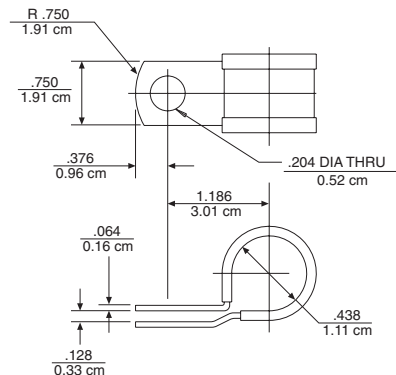

## General Specifications

### Sensing

Range: 381 mm (15")  
Sonic Frequency: 180 kHz  
Minimum-size Detection:  
9.5 mm (0.375") with object close to sensor  
Repeatability: 0.30 mm (0.012") max.

### Power Requirements

Supply Voltage:  
12 to 24 VDC  $\pm$  10%, regulated supply  
Current Consumption: 60 mA max.  
(excluding load) per set  
Power Consumption: 1.2 W max.  
(excluding load) @ 15 VDC per set

### Output

NPN Sinking: 0 to 50 V, max.  
Maximum on state voltage 0.2 V @ 100 mA  
PNP Sourcing: 100 mA @ 24 VDC, max.  
Receiver red LED "ON" when beam is received

### Response Time

"On" 0.6 ms or 4 ms  
(Model dependent - see selection chart)  
"Off" 0.6 ms or 4 ms  
(Model dependent - see selection chart)

### Indicators

Transmitter: None  
Receiver:  
Red LED: Illuminated when sonic energy is received, regardless of output state.

### Connections

Cable Style Models:  
Transmitter:  
305 cm (10'), 20 AWG, foil shield,  
lead-free, PVC jacket, 2-conductor  
Receiver:  
305 cm (10'), 22 AWG, foil shield,  
lead-free, PVC jacket, 3-conductor  
Connector Style Models:  
Amphenol (nonwatertight) quick-disconnect style models:  
Model AC100, Transmitter:  
305 cm (10'), 20 AWG, foil shield,  
lead-free, PVC jacket, 2-conductor  
Model AC150, Receiver:  
305 cm (10'), 22 AWG, foil shield,  
lead-free, PVC jacket, 3-conductor  
Watertight (WTC) quick-disconnect style models:  
Model AC107, Transmitter:  
7/8-16 mini, 4 m (12'), 18 AWG, 2-conductor  
Model AC108, Receiver:  
7/8-16 mini, 4 m (12'), 18 AWG, 3-conductor

### Protection

Power Supply: ESD  
Outputs: ESD

### Environmental

Operating Temperature Range:  
0° to 60°C  
Storage Temperature Range: -40° to 100°C  
(-40° to 212°F)  
Operating Humidity: 100%  
Protection Ratings:  
Cable Style: NEMA 4X, IP67  
Amphenol Quick-disconnect: NEMA 1  
Watertight Quick-disconnect: NEMA 4X, IP67  
Chemical Resistance: Resists most acids and bases, including most food products. Polypropylene transducer face is available to provide resistance to corrosive chemicals, solvents, and steam.

### Construction

Housing:  
Shock and vibration resistant  
Case: Stainless steel  
Remote Cable: Stainless steel armor  
Transducer Face: silicone rubber, standard  
Sensor Cables: Nontoxic PVC jacket  
LED: Polycarbonate

## Accessories

**Model AC100**, 2-conductor, transmitter connector cable, 3 m (10'), for all SM700 series Amphenol connector-style transmitters

**Model AC107**, Straight, 7/8-16 mini, 2-pin, 2-conductor, mating connector cable, 4 m (12'), for all SM700 series watertight, connector-style, transmitters

**Model AC108**, Straight, 7/8-16 mini, 3-pin, 3-conductor, mating connector cable, 4 m (12'), for all SM700 series watertight, connector-style receivers

**Model AC150**, 3-conductor, receiver connector cable, 3 m (10'), for all SM700 series Amphenol connector-style receivers

**Model AC160**, Cable grip for all cable-style, thru-beam sensors

**Model AC201**, Stainless, right-angle, single-thru-beam-sensor, mounting bracket, slotted for adjustment

**Model AC213**, Stainless and Teflon, remote sensing probe, mounting bracket

See page 7-1 for accessory photos.

# Transmitter Selection Chart

## SM700 Series MICROSONIC® Remote Thru-Beam

Transmitter Model No.	Receiver Model No.	Power Version	Connection Style	NEMA Rating	Transmitter/Receiver Housing	Sensing Range	Remote Armor Cable	Remarks
SM700•	SM750	12-24VDC	Quick Disconnect		Stainless	381mm(15")		Amphenol connector
	SM754	12-24VDC	Quick Disconnect		Stainless	381mm(15")		Amphenol connector
	SM757	12-24VDC	Quick Disconnect		Stainless	381mm(15")		Amphenol connector
	SM758	12-24VDC	Quick Disconnect		Stainless	381mm(15")		Amphenol connector
SM701•	SM751	12-24VDC	305cm(10') cable	4X, IP67	Stainless	381mm(15")		
	SM755	12-24VDC	305cm(10') cable	4X, IP67	Stainless	381mm(15")		
	SM756	12-24VDC	305cm(10') cable	4X, IP67	Stainless	381mm(15")		
	SM754 R4	12-24VDC	305cm(10') cable	4X, IP67	Stainless	381mm(15")		
	SM759	12-24VDC	305cm(10') cable	4X, IP67	Stainless	381mm(15")		
SM701 R4	SM751	12-24VDC	305cm(10') cable	4X, IP67	Stainless	381mm(15")	1016mm(40")	
	SM755	12-24VDC	305cm(10') cable	4X, IP67	Stainless	381mm(15")		
	SM756	12-24VDC	305cm(10') cable	4X, IP67	Stainless	381mm(15")		
	SM756 R4	12-24VDC	305cm(10') cable	4X, IP67	Stainless	381mm(15")		
	SM759	12-24VDC	305cm(10') cable	4X, IP67	Stainless	381mm(15")		
SM701 R5	SM751	12-24VDC	305cm(10') cable	4X, IP67	Stainless	381mm(15")	1270mm(50")	
	SM755	12-24VDC	305cm(10') cable	4X, IP67	Stainless	381mm(15")		
	SM756	12-24VDC	305cm(10') cable	4X, IP67	Stainless	381mm(15")		
	SM756 R4	12-24VDC	305cm(10') cable	4X, IP67	Stainless	381mm(15")		
	SM759	12-24VDC	305cm(10') cable	4X, IP67	Stainless	381mm(15")		
SM705	SM750	12-24VDC	Quick Disconnect		Stainless	381mm(15")		Variable power, Amphenol connector
	SM754	12-24VDC	Quick Disconnect		Stainless	381mm(15")		Variable power, Amphenol connector
	SM757	12-24VDC	Quick Disconnect		Stainless	381mm(15")		Variable power, Amphenol connector
	SM758	12-24VDC	Quick Disconnect		Stainless	381mm(15")		Variable power, Amphenol connector

• = Most commonly stocked sensors

All possible sensor configurations are not listed here.

# Receiver Selection Chart

## SM700 Series (cont.) MICROSONIC® Remote Thru-Beam

Receiver Model No.	Transmitter Model No.	Power Version	Connection Style	NEMA Rating	Transmitter/Receiver Housing	Sensing Range	Remote Armor Cable	Response Time	Remarks (Outputs N.O. unless noted)
SM750•	SM700	12-24VDC	Quick Disconnect		Stainless	381mm(15")		On 4ms, Off 4ms	NPN Sinking, Amphenol connector
	SM705	12-24VDC	Quick Disconnect		Stainless	381mm(15")		On 4ms, Off 4ms	NPN Sinking, Amphenol connector
SM751•	SM701	12-24VDC	305cm(10') cable	4X, IP67	Stainless	381mm(15")		On 4ms, Off 4ms	NPN Sinking
	SM701 R4	12-24VDC	305cm(10') cable	4X, IP67	Stainless	381mm(15")		On 4ms, Off 4ms	NPN Sinking
	SM701 R5	12-24VDC	305cm(10') cable	4X, IP67	Stainless	381mm(15")		On 4ms, Off 4ms	NPN Sinking
SM754	SM700	12-24VDC	Quick Disconnect		Stainless	381mm(15")		On .6ms, Off .6ms	NPN Sinking, Amphenol connector
	SM705	12-24VDC	Quick Disconnect		Stainless	381mm(15")		On .6ms, Off .6ms	NPN Sinking, Amphenol connector
SM755	SM701	12-24VDC	305cm(10') cable	4X, IP67	Stainless	381mm(15")		On .6ms, Off .6ms	NPN Sinking
	SM701 R4	12-24VDC	305cm(10') cable	4X, IP67	Stainless	381mm(15")		On .6ms, Off .6ms	NPN Sinking
	SM701 R5	12-24VDC	305cm(10') cable	4X, IP67	Stainless	381mm(15")		On .6ms, Off .6ms	NPN Sinking
SM756	SM701	12-24VDC	305cm(10') cable	4X, IP67	Stainless	381mm(15")		On 4ms, Off 4ms	PNP Sourcing
	SM701 R4	12-24VDC	305cm(10') cable	4X, IP67	Stainless	381mm(15")		On 4ms, Off 4ms	PNP Sourcing
	SM701 R5	12-24VDC	305cm(10') cable	4X, IP67	Stainless	381mm(15")		On 4ms, Off 4ms	PNP Sourcing
SM756 R4	SM701	12-24VDC	305cm(10') cable	4X, IP67	Stainless	381mm(15")	1016mm(40")	On 4ms, Off 4ms	PNP Sourcing
	SM701 R4	12-24VDC	305cm(10') cable	4X, IP67	Stainless	381mm(15")		On 4ms, Off 4ms	PNP Sourcing
	SM701 R5	12-24VDC	305cm(10') cable	4X, IP67	Stainless	381mm(15")		On 4ms, Off 4ms	PNP Sourcing
SM757	SM700	12-24VDC	Quick Disconnect		Stainless	381mm(15")		On .6ms, Off .6ms	PNP Sourcing, Amphenol connector
	SM705	12-24VDC	Quick Disconnect		Stainless	381mm(15")		On .6ms, Off .6ms	PNP Sourcing, Amphenol connector
SM758	SM700	12-24VDC	Quick Disconnect		Stainless	381mm(15")		On 4ms, Off 4ms	PNP Sourcing, Amphenol connector
	SM705	12-24VDC	Quick Disconnect		Stainless	381mm(15")		On 4ms, Off 4ms	PNP Sourcing, Amphenol connector
SM759	SM701	12-24VDC	305cm(10') cable	4X, IP67	Stainless	381mm(15")		On .6ms, Off .6ms	PNP Sourcing
	SM701 R4	12-24VDC	305cm(10') cable	4X, IP67	Stainless	381mm(15")		On .6ms, Off .6ms	PNP Sourcing
	SM701 R5	12-24VDC	305cm(10') cable	4X, IP67	Stainless	381mm(15")		On .6ms, Off .6ms	PNP Sourcing

• = Most commonly stocked sensors

All possible sensor configurations are not listed here.

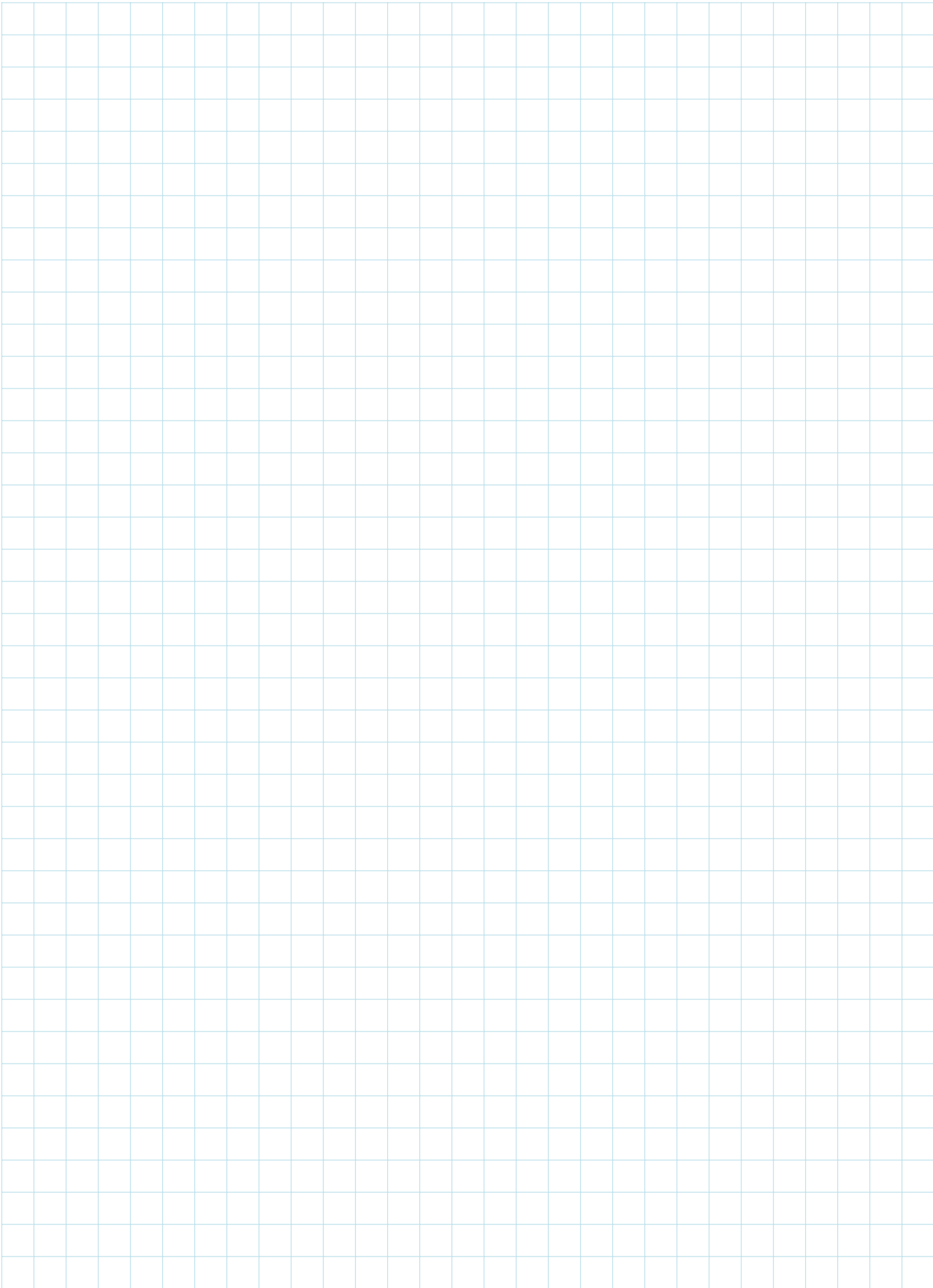

## MICROSONIC® Thru-beam Sensors



- *Ideal for small object detection*
- *Sensing ranges up to 1016 mm (40")*
- *Available in barrel or flat-profile types*
- *Ideal for limited space installations*
- *CE certified*

### **Extremely reliable thru-beam sensing in a smaller package and ranges up to 1016 mm (40")**

They are miniature in size, powerful in sensing capability, and the product of the same reliable, world-leading ultrasonic technology built into the original MICROSONIC® SM100 series. The SM800 series of thru-beam sensors is available in 18 mm FDA rated ULTEM® plastic and stainless steel barrel housings and ULTEM® plastic "flat-profile" housings designed for small-object applications where installation space is limited. "Across-the-line" sensing versatility includes standard sensing ranges of 102 mm (4") and 305 mm (12") and extended sensing ranges of 610 mm (24") and 1016 mm (40").

The MICROSONIC® SM800 thru-beam sensors are ideal for detecting small objects of any color or material, transparent or

opaque, regular or irregular shaped, as well as those with either poor reflective or fully sound-absorbing surfaces. Response times of either 4 ms or 0.4 ms allows for the detection of objects moving at speeds of over 2000 units per minute. "Smart" sensor enhancements include clean switching delay and output polarity variations.

With protection ratings of NEMA 4X and IP67, the sensors are resistant to dust, 100% humidity, most acids and bases, and high-pressure washdowns that often times leave water buildup on the sensing face. Unlike photoelectrics, these miniature thru-beam sensors are virtually unaffected by splashing food, caustic cleaning solutions, and changing light conditions or colors. Shielding and filtering makes the fully encapsulated sensors highly immune to radiated or conducted energy. They are also tolerant of high noise levels, vibration, and a storage temperature range of -10° to 100° C.

Equipped with sinking type (NPN) and sourcing type (PNP) outputs, the 12 to 24 VDC circuitry and output signal make these sensors directly compatible with many programmable logic controllers, computers, and other logic control systems. Available in either cable or "micro" connector style, the receiver units of the CE certified sensors have an amber LED that illuminates when sonic energy is received, regardless of output state. The micro connector style receivers are also equipped with a green LED to indicate that power is being supplied to the sensor.

Rugged, robust, and easy to set up, these sensors need no maintenance and require no sensitivity adjustments to compensate for inconsistent

product materials.

Applications include the detection of such objects as clear 2-liter P.E.T. bottles, metal parts as small as 6.4 mm (0.25") diameter, powdery products, the new shaped cans, photographic films, fabrics, and corrugated boxes up to 991 mm (39") wide. They are the solution for lead-edge detection and a wide variety of applications that require repeatable and reliable, cost-effective, sensing performance day in and day out.

### Operation

The MICROSONIC® SM800 series sensors are continuous-wave devices that consist of a high-frequency transmitter and receiver positioned opposite each other, illustrated at right, at a distance of up to 1016 mm (40"). During operation, the transmitter sends a continuous ultrasonic beam which is picked up by the receiver. When an object of any material or shape passes between the transmitter and receiver and breaks the beam, object presence is detected and the output of the receiver switches. Or, when a hole allows the beam to pass through to the receiver, the output of the receiver switches.

With all circuitry compactly sealed in the plastic and stainless steel transmitter and receiver probes, the MICROSONIC® sensors boast a narrow, constant, ultra-high-frequency sonic beam for high sensing resolution. The sensors are available in two different operating frequencies: 500 kHz for a standard sensing range of up to 305 mm (12") and 200 kHz for an extended sensing range of up to 1016 mm (40").

The thru-beam sensing mode is set up by mounting the sensors on the same axis opposite each other as shown in Figure 1.

Positioning of the transmitter and receiver for operation is extremely important for the reliable detection of objects, particularly small ones. As the figure also shows, the width of the transmitted sound beam initially expands at a rate of 10 degrees (5 degrees each side of the common axis) for the 500 kHz models (and 20 degrees for the 200 kHz models) as the distance between the transmitter and receiver increases. This means that, if the distance between the transmitter and receiver is too great and the object is too small, it is possible for the beam to "wrap around" the object enough to not cause the receiver output to switch, as shown in Figure 2.

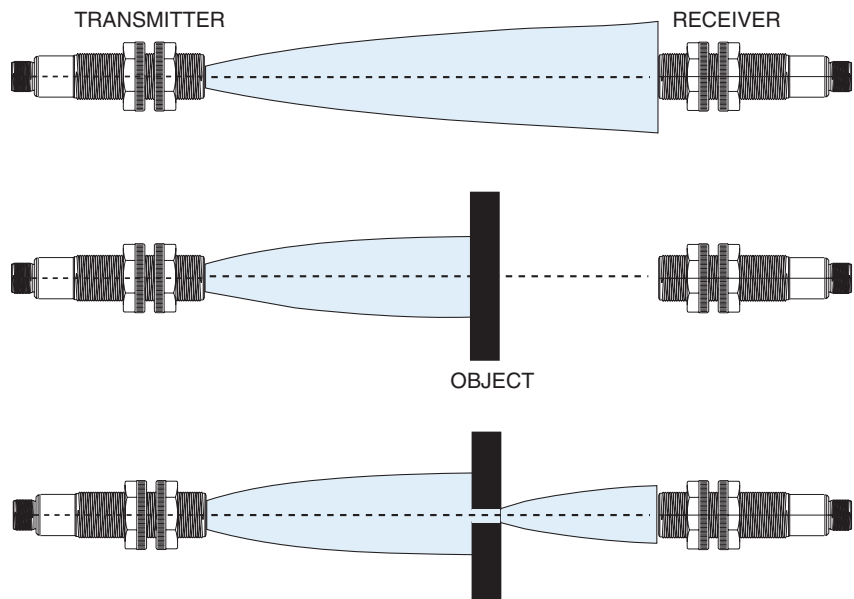

500 kHz Standard Sensing Range Models

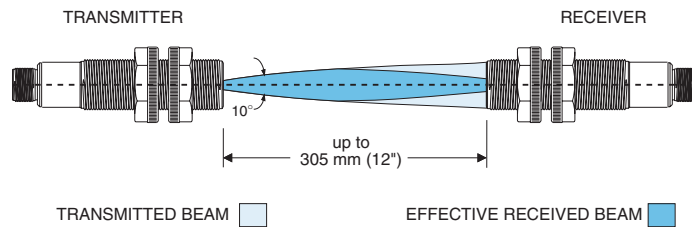

200 kHz Extended Sensing Range Models

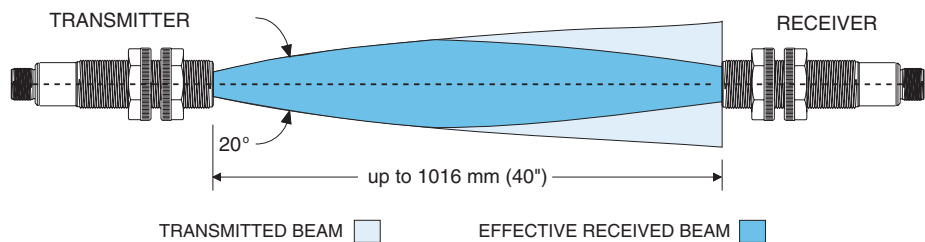

Figure 1, Thru-beam Patterns and Ranges

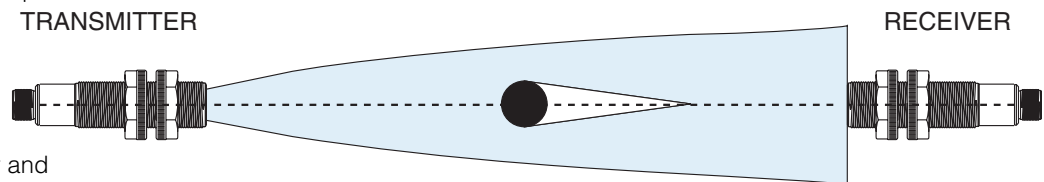

Figure 2



Therefore, reliable detection of 13 mm (0.5") inch wide or smaller objects is achieved when the objects are allowed to pass near the face of either the transmitter or receiver. An alternative approach is to position the transmitter and receiver on parallel axes, as shown in Figure 3, so as to reduce the amount of beam reaching the receiver.

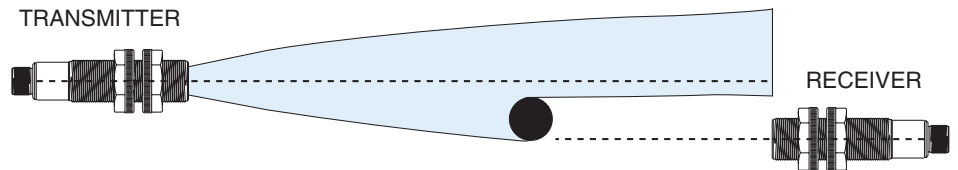

Figure 3

Where sensing distances are adversely affected as the environment becomes more contaminated, the MICROSONIC® sensors remain constant under adverse conditions where other sensor types fail.

### Mounting

The Model SM800 series sensors should be mounted in brackets that allow them to be adjusted for proper alignment on the same axis. Hyde Park offers the Model AC226 stainless and polyamide conveyor-rail clamp/bracket set, Model AC227 large, right-angle, stainless mounting bracket, Model AC228 small, right-angle, stainless, mounting bracket, Model AC231 straight, stainless, mounting bracket and Model AC232 s-shaped, stainless, mounting bracket which are illustrated, with dimensions, on Pages 5-37 and 5-38.

### Model Reference Guide - SM800 Series

Use the guide below to ensure the correct model number is specified for the application. Please note that not all sensor model combinations are available.

**EXAMPLE MODEL:** **SM801A-40-01S**

**MICROSONIC® Product Series** \_\_\_\_\_

**Power/Connection Type** \_\_\_\_\_

0... 12 to 24 VDC / cable style  
5... 12 to 24 VDC / "micro" connector style

**Sensing Type** \_\_\_\_\_

0... Transmitter  
1... Receiver

**Design Level** \_\_\_\_\_

A... Applies to all models

**Sensing Range** \_\_\_\_\_

04... Low-power: 102 mm (4")\*  
12... Standard: 305 mm (12")  
24... Extended-range: 610 mm (24")  
40... Extended-range: 1016 mm (40")

**Sensing Variations - Transmitter** \_\_\_\_\_

00... Standard  
02... Variable power

**Sensing Variations - Receiver\*\*\*** \_\_\_\_\_

00... N.O. Output, 4 ms on & off  
01... N.O. Fast Response, 0.4 ms on & off  
10... N.C. Output, 4 ms on & off  
11... N.C. Output, Fast Response, 0.4 ms on & off

#### Housing Types

- ... No letter indicates standard ULTEM® - 18 mm dia. housing
- FP... ULTEM® flat-profile housing
- S... SS303 stainless steel - 18 mm dia. housing

\* Used to detect narrow objects

\*\* ULTEM® is a registered trademark of the General Electric Co.

\*\*\* N.O. - "Normally Open," outputs off when beam broken

N.C. - "Normally Closed," outputs on when beam broken

### Electrical Wiring

The sensor wires must be run in conduit free of any AC power or control wires.

#### Transmitters

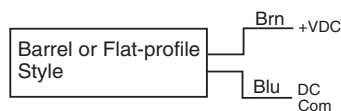

#### Receivers

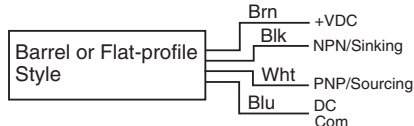

### Receiver (SM801, SM851) Outputs

#### NPN Sinking and PNP Sourcing

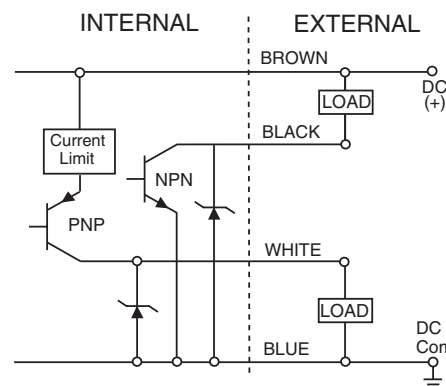

#### Receiver Connector Pins

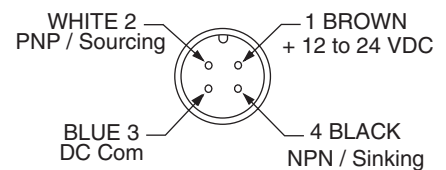

## Dimensions

### Barrel Cable Style

(ULTEM® plastic and stainless steel)

Transmitter Models:

SM800A-04-XX, 800A-12-XX,  
800A-24-XX, 800A-40XX  
SM800A-04-XXS, 800A-12-XXS,  
800A-24-XXS, 800A-40XXS

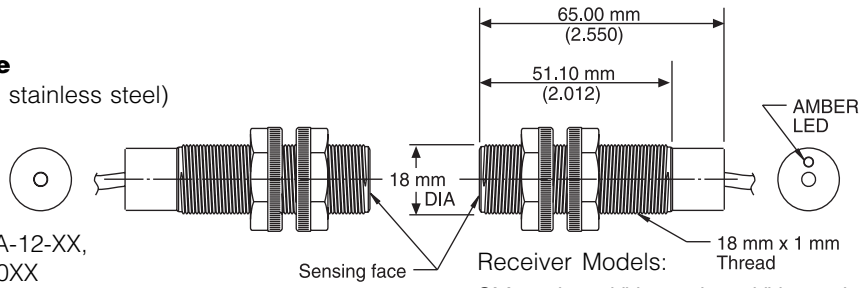

Receiver Models:

SM801A-04-XX, 801A-12-XX, 801A-24-XX, 801A-40-XX  
SM 801A-04-XXS, 801A-12-XXS, 801A-24-XXS, 801A-40-XXS

### Barrel Connector Style

(ULTEM® plastic and stainless steel)

Transmitter Models:

SM850A-04-XX, 850A-12-XX,  
850A-24-XX, 850A-40-XX  
SM850A-04-XXS, 850A-12-XXS,  
850A-24-XXS, 850A-40-XXS

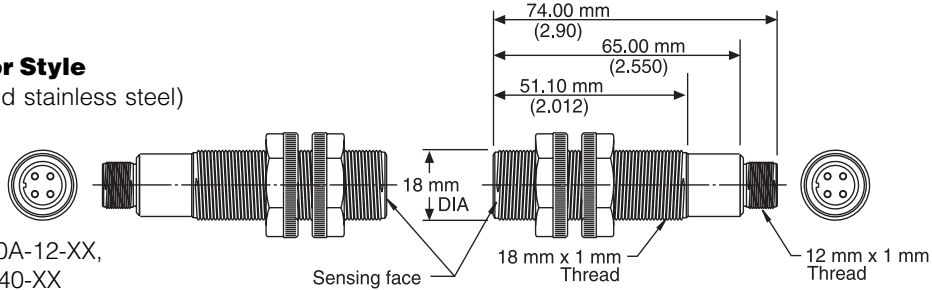

Receiver Models:

SM851A-04-XX, 851A-12-XX, 851A-24-XX, 851A-40-XX  
SM851A-04-XXS, 851A-12-XXS, 851A-24-XXS, 851A-40-XXS

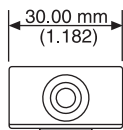
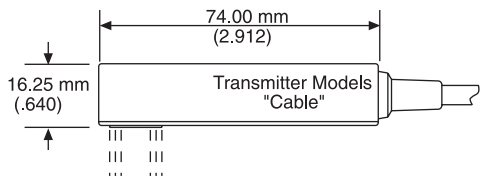
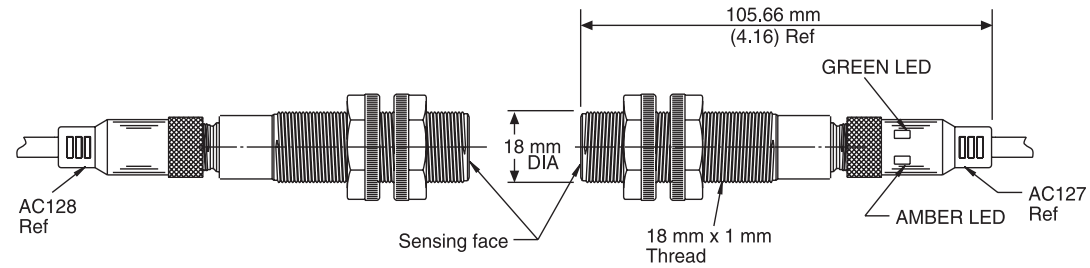
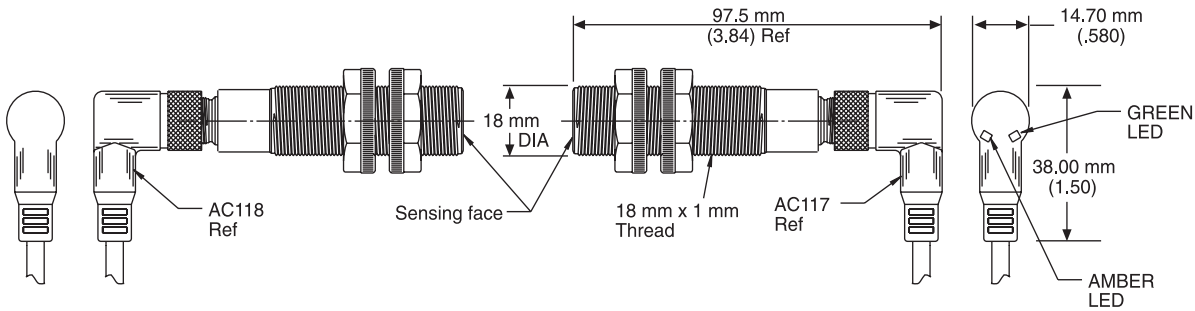

### "Flat-profile" Cable Style (ULTEM® plastic)

Transmitter Models:

SM800A-04-XXFP, 800A-12-XXFP, 800A-24-XXFP,  
800A-40XXFP

### "Flat-profile" Cable Style (ULTEM® plastic)

Receiver Models:

SM801A-04-XXFP, 801A-12-XXFP, 801A-24-XXFP,  
801A-40-XXFP

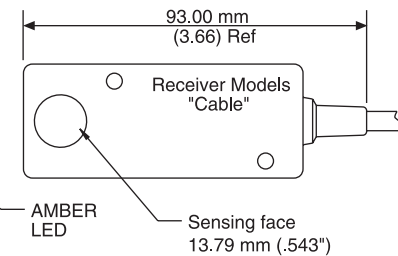
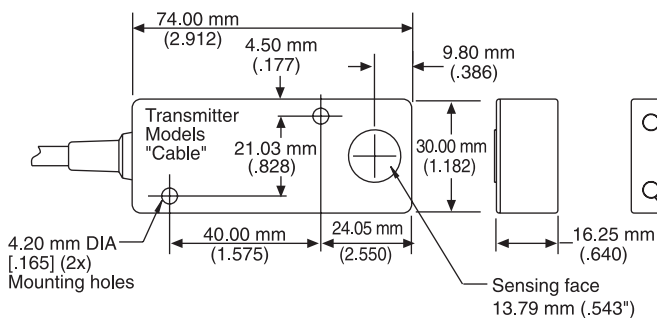

### "Flat-profile" Connector Style

(ULTEM® plastic)  
 Transmitter Models  
 SM850A-04-XXFP,  
 SM850A-12-XXFP,  
 SM850A-24-XXFP,  
 SM850A-40-XXFP

### "Flat-profile" Connector Style

(ULTEM® plastic)  
 Receiver Models  
 SM851A-04-XXFP,  
 SM851A-12-XXFP,  
 SM851A-24-XXFP,  
 SM851A-40-XXFP

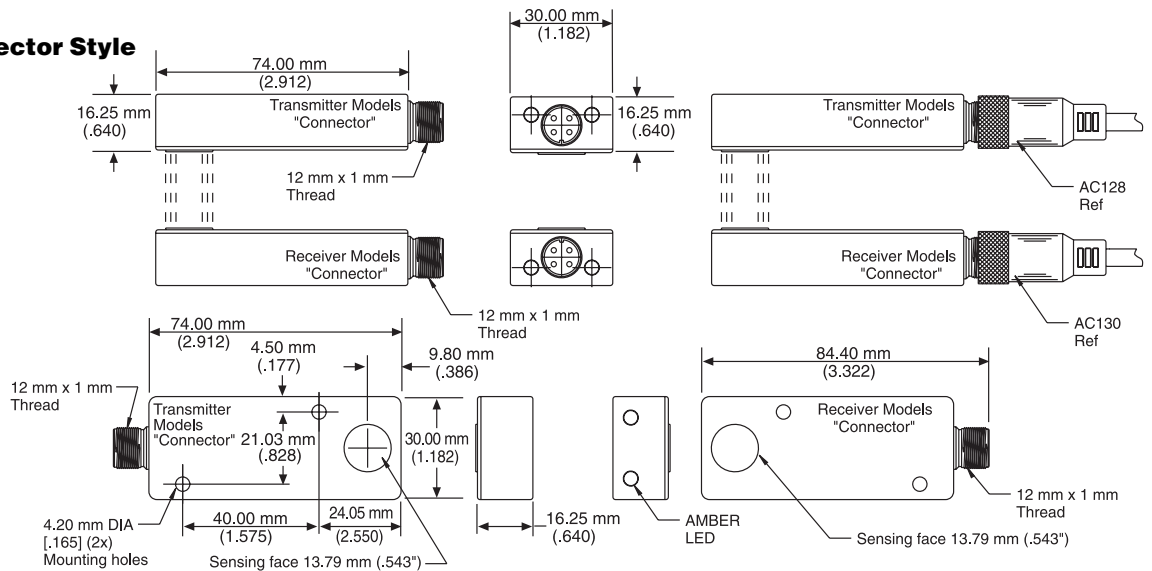

### Mounting Accessories

**AC117** Right-angle, M12 micro, 4-conductor, connector/cable assembly with built-in LEDs (for SM851 series Receivers)

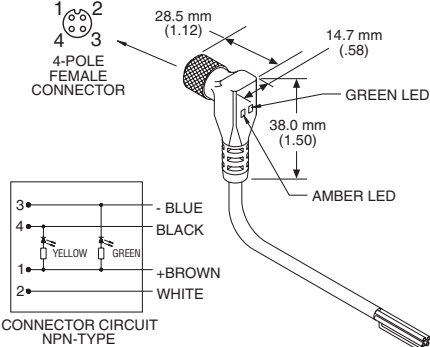

**AC118** Right-angle, M12 micro, 2-conductor, connector/cable assembly (for SM850 series Transmitters)

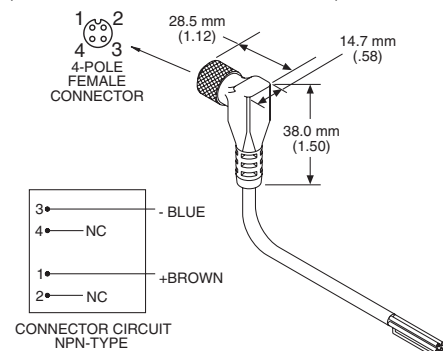

**AC226** Stainless and polyamide conveyor-rail clamp/bracket set (for 18 mm barrel sensors)

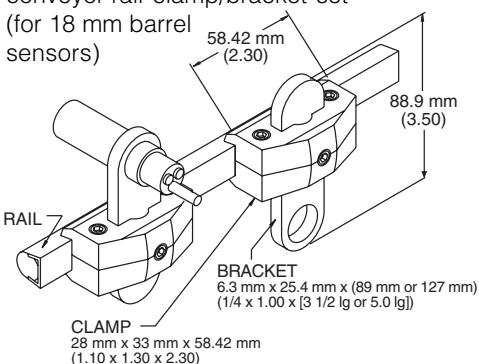

**AC127** Straight, M12 micro, 4-conductor, connector/cable assembly, 5 m (16'), with built-in LEDs (for SM851 series connector-style Receivers)

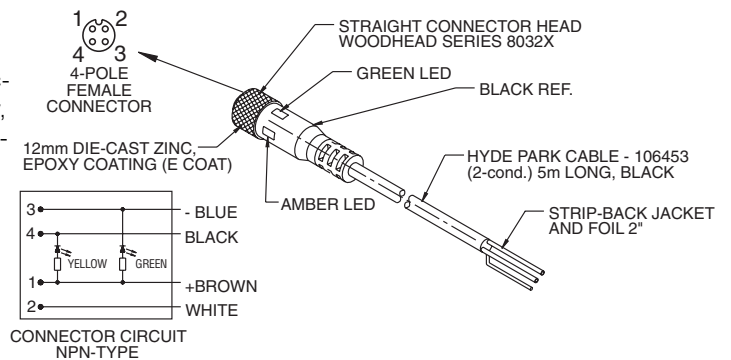

**AC128** Straight, M12 micro, 2-conductor, connector/cable assembly, 5 m (16') (for SM850 Series, flat-profile, connector-style Transmitters)

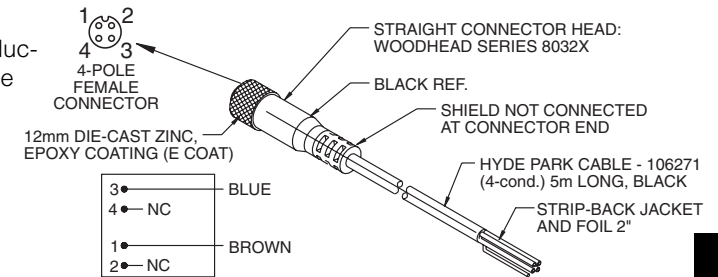

**AC130** Straight, M12 micro, 4-conductor, connector/cable assembly, 5 m (16') (for SM851 Series, flat-profile, connector-style Receivers)

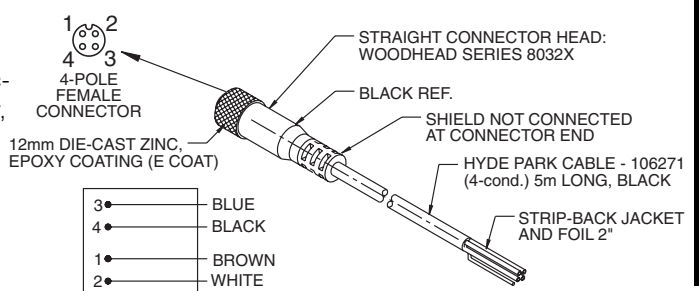

**AC227** Large, right-angle, stainless, mounting bracket (for 18 mm barrel sensors)

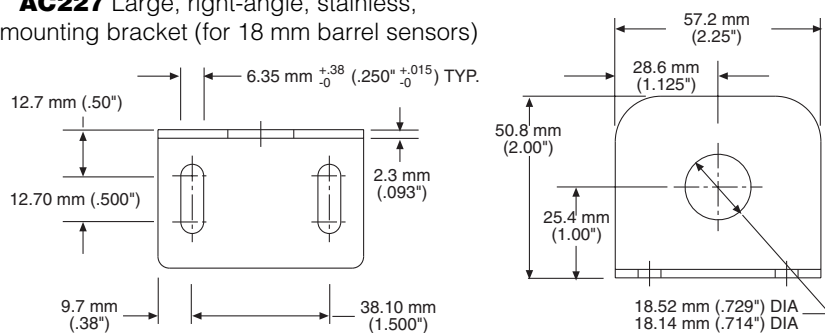

MICROSONIC® SM800 SERIES

## Mounting Accessories (cont.)

### AC231 Straight, stainless mounting bracket (for flat-profile sensors)

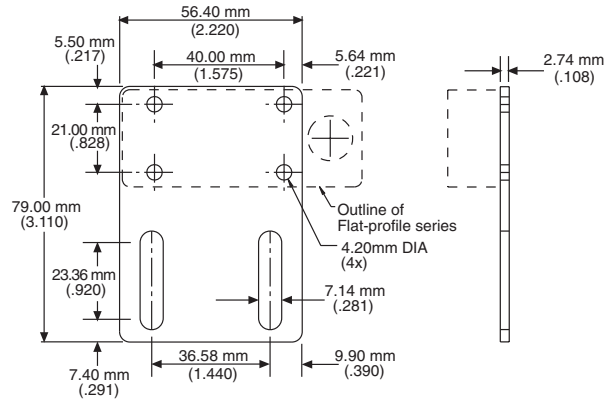

### AC232 S-shaped, stainless mounting bracket (for flat-profile sensors)

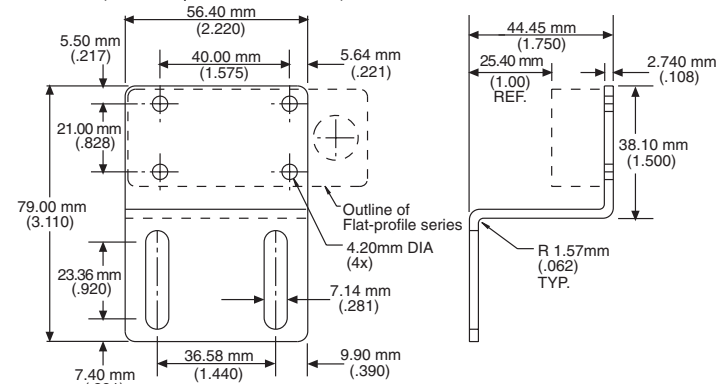

### AC228 Small, right-angle, stainless, mounting bracket (for 18 mm barrel sensors)

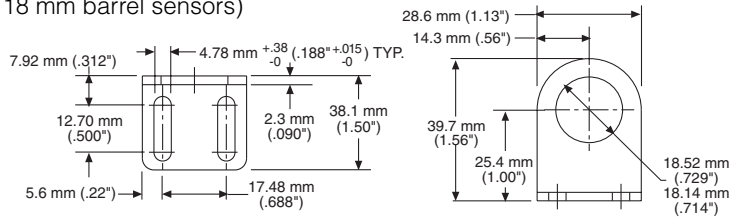

## General Specifications

### Sensing

#### Ranges:

102 mm (4"), 305 mm (12"),  
610 mm (24"), 1016 mm (40")

#### Sonic Frequency:

500 kHz: 102 mm (4") & 305 mm (12") ranges  
200 kHz: 610 mm (24") & 1016 mm (40") ranges

#### Minimum-size Detection:

12.7 mm (0.50") at 102 mm (4") range  
25 mm (1.0") at 305 mm (12") range  
38 mm (1.5") at 610 mm (24") range  
114 mm (4.5") at 1016 mm (40") range

#### Repeatability: 0.79 mm (0.031") typical

### Power Requirements

Supply Voltage: 12 to 24 VDC  $\pm$  10%,  
regulated supply

Current Consumption: 90 mA per set

Power Consumption: 2.2 W max. @ 24 VDC per set

### Output

NPN Sinking: 0 to 30 V

Maximum on state voltage 0.2 V @ 100 mA

PNP Sourcing: 100 mA @ 24 VDC, max.

Receiver amber LED "ON" when beam is received

### Response Time

"On" 0.4 ms or 4 ms

(Model dependent - see selection chart)

"Off" 0.4 ms or 4 ms

(Model dependent - see selection chart)

### Indicators

Transmitter: None

Receiver:

Amber LED: Illuminated when sonic energy is received, regardless of output state.

Green LED: Indicates that power is being supplied ("micro" connector style only).

### Connections

Transmitter cable style model SM800 series:

3 m (10'), 24 AWG, foil shield, lead-free,  
PVC jacket  
2-conductor

Transmitter connector style model SM850 series:

Model AC118 M12 micro, watertight quick-disconnect, right-angle, 5 m (16'), 12 mm, 24 AWG, 2-conductor, foil shield

Receiver cable style model SM801 series:

3 m (10'), 24 AWG, foil shield, lead-free,  
PVC jacket 4-conductor

Receiver connector style model SM851 series:

Model AC117 M12 micro, watertight quick-disconnect, right-angle, 5 m (16'), 12 mm, 24 AWG, 4-conductor, foil shield  
(Note: Connector-style sensor does not have LEDs. The cable assembly provides this feature.)

### Protection

Power Supply: Current-limited over-voltage, ESD,  
reverse polarity

Outputs: Current-limited over-voltage, ESD,  
over-current

### Environmental

Operating Temperature Range:

0° to 60°C

Storage Temperature Range: -40° to 100°C

(-40° to 212°F)

Operating Humidity: 100%

Protection Ratings:

Cable Style: NEMA 4X, IP67

Watertight "micro" quick-disconnect:  
NEMA 4X, IP67

Chemical Resistance: Resists most acids and  
bases, including most food products.

### Agency Approvals

CE Mark: CE conformity is declared to:

EN61010-1:1990 including amend. No. 1:1992  
and amend. No.2:1995, EN50082-1, EN55011  
Group 1 Class B.

Declaration of Conformity available upon request

### Construction

Housing:

Shock and vibration resistant

Case (barrel and flat-profile types): ULTEM®\*  
blue plastic (FDA Approved)

(SS303 stainless steel available for barrel types)

Transducer Face: Silicone rubber - gray

Sensor Cables: Lead-free PVC jacket,  
black (Model AC117)

LED: Polycarbonate

\* ULTEM® is a registered trademark of The General Electric Co.

## Accessories

### 18 mm Barrel Mounting Hardware and Cables

**Model AC117**, Right-angle, M12 micro, 4-conductor, connector/cable assembly, 5 m (16'), with built-in LEDs, for SM851 series receivers

**Model AC118**, Right-angle, M12 micro, 2-conductor, connector/cable assembly, 5 m (16'), for SM850 series transmitters

**Model AC127**, Straight, M12 micro, 4-conductor, connector/cable assembly, 5 m (16'), with built-in LEDs for SM851 series connector-style receivers

**Model AC226**, Stainless and polyamide conveyor-rail clamp/bracket set

**Model AC227**, Large, right-angle, stainless, mounting bracket

**Model AC228**, Small, right-angle, stainless, mounting bracket

### Flat-profile Mounting Hardware and Cables

**Model AC128**, Straight, M12 micro, 4-pin, 2-conductor, connector/cable assembly, 5 m (16'), for SM850 series, flat-profile, connector-style Transmitters

**Model AC130**, Straight, M12 micro, 4-conductor, connector/cable assembly, 5 m (16'), for flat-profile, for SM851 series, flat-profile, connector-style receivers

**Model AC231**, Straight, stainless, mounting bracket

**Model AC232**, S-shaped, stainless, mounting bracket

See page 7-1 for accessory photos.

# Selection Chart

## SM800 Series MICROSONIC® Thru-Beam

Transmitter	Receiver	Model No.	Power Version	Connecton Style	Sensing Range	Materials				Transmitter		Sensing Variations		N.C. Output	N.C. Output Fast Response
						Transducer	Housing	Transmitter	Receiver	Standard	Variable Power	Standard	Fast Response .4ms on & off		
						Silicone*	18mm ULTEM®*	18mm Stainless	Flat-profile	Standard	Variable Power	Standard	Fast Response .4ms on & off	N.C. Output	N.C. Output Fast Response
SM800A-04-00•	SM801A-04-00•		12-24VDC	10' cable	4"	■	■			■		■			
SM800A-04-00FP•	SM801A-04-00FP•		12-24VDC	10' cable	4"	■			■	■		■			
SM800A-04-00S•	SM801A-04-00S•		12-24VDC	10' cable	4"	■		■		■		■			
SM800A-04-00	SM801A-04-01		12-24VDC	10' cable	4"	■	■			■		■			
SM800A-04-00FP	SM801A-04-01FP		12-24VDC	10' cable	4"	■			■	■		■			
SM800A-04-00S	SM801A-04-01S		12-24VDC	10' cable	4"	■		■		■		■			
SM800A-04-00	SM801A-04-10		12-24VDC	10' cable	4"	■	■			■				■	
SM800A-04-00FP	SM801A-04-10FP		12-24VDC	10' cable	4"	■			■	■				■	
SM800A-04-00S	SM801A-04-10S		12-24VDC	10' cable	4"	■		■		■				■	
SM800A-04-00	SM801A-04-11		12-24VDC	10' cable	4"	■	■			■					■
SM800A-04-00FP	SM801A-04-11FP		12-24VDC	10' cable	4"	■			■	■					■
SM800A-04-00S	SM801A-04-11S		12-24VDC	10' cable	4"	■		■		■					■
SM800A-04-02	SM801A-04-00		12-24VDC	10' cable	4"	■	■			■	■				
SM800A-04-02FP	SM801A-04-00FP		12-24VDC	10' cable	4"	■			■	■	■				
SM800A-04-02S	SM801A-04-00S		12-24VDC	10' cable	4"	■		■		■	■				
SM800A-04-02	SM801A-04-01		12-24VDC	10' cable	4"	■	■			■		■			
SM800A-04-02FP	SM801A-04-01FP		12-24VDC	10' cable	4"	■			■	■		■			
SM800A-04-02S	SM801A-04-01S		12-24VDC	10' cable	4"	■		■		■		■			
SM800A-04-02	SM801A-04-10		12-24VDC	10' cable	4"	■	■			■				■	
SM800A-04-02FP	SM801A-04-10FP		12-24VDC	10' cable	4"	■			■	■				■	
SM800A-04-02S	SM801A-04-10S		12-24VDC	10' cable	4"	■		■		■				■	
SM800A-04-02	SM801A-04-11		12-24VDC	10' cable	4"	■	■			■					■
SM800A-04-02FP	SM801A-04-11FP		12-24VDC	10' cable	4"	■			■	■					■
SM800A-04-02S	SM801A-04-11S		12-24VDC	10' cable	4"	■		■		■					■
SM800A-12-00	SM801A-12-00		12-24VDC	10' cable	12"	■	■			■	■				
SM800A-12-00FP	SM801A-12-00FP		12-24VDC	10' cable	12"	■			■	■	■				
SM800A-12-00S	SM801A-12-00S		12-24VDC	10' cable	12"	■		■		■	■				
SM800A-12-00•	SM801A-12-01•		12-24VDC	10' cable	12"	■	■			■		■			
SM800A-12-00FP•	SM801A-12-01FP•		12-24VDC	10' cable	12"	■			■	■		■			
SM800A-12-00S•	SM801A-12-01S•		12-24VDC	10' cable	12"	■		■		■		■			
SM800A-12-00	SM801A-12-10		12-24VDC	10' cable	12"	■	■			■				■	
SM800A-12-00FP	SM801A-12-10FP		12-24VDC	10' cable	12"	■			■	■				■	
SM800A-12-00S	SM801A-12-10S		12-24VDC	10' cable	12"	■		■		■				■	
SM800A-12-00	SM801A-12-11		12-24VDC	10' cable	12"	■	■			■					■
SM800A-12-00FP	SM801A-12-11FP		12-24VDC	10' cable	12"	■			■	■					■
SM800A-12-00S	SM801A-12-11S		12-24VDC	10' cable	12"	■		■		■					■
SM800A-12-02	SM801A-12-00		12-24VDC	10' cable	12"	■	■			■	■				
SM800A-12-02FP	SM801A-12-00FP		12-24VDC	10' cable	12"	■			■	■	■				
SM800A-12-02S	SM801A-12-00S		12-24VDC	10' cable	12"	■			■	■	■				
SM800A-12-02	SM801A-12-01		12-24VDC	10' cable	12"	■	■			■		■			
SM800A-12-02FP	SM801A-12-01FP		12-24VDC	10' cable	12"	■			■	■		■			
SM800A-12-02S	SM801A-12-01S		12-24VDC	10' cable	12"	■		■		■		■			
SM800A-12-02	SM801A-12-10		12-24VDC	10' cable	12"	■	■			■				■	
SM800A-12-02FP	SM801A-12-10FP		12-24VDC	10' cable	12"	■			■	■				■	
SM800A-12-02S	SM801A-12-10S		12-24VDC	10' cable	12"	■		■		■				■	
SM800A-12-02	SM801A-12-11		12-24VDC	10' cable	12"	■	■			■					■
SM800A-12-02FP	SM801A-12-11FP		12-24VDC	10' cable	12"	■			■	■					■
SM800A-12-02S	SM801A-12-11S		12-24VDC	10' cable	12"	■		■		■					■
SM800A-24-00•	SM801A-24-00•		12-24VDC	10' cable	24"	■	■			■	■				
SM800A-24-00FP•	SM801A-24-00FP•		12-24VDC	10' cable	24"	■			■	■	■				
SM800A-24-00S•	SM801A-24-00S•		12-24VDC	10' cable	24"	■		■		■	■				
SM800A-24-00	SM801A-24-01		12-24VDC	10' cable	24"	■	■			■		■			
SM800A-24-00FP	SM801A-24-01FP		12-24VDC	10' cable	24"	■			■	■		■			
SM800A-24-00S	SM801A-24-01S		12-24VDC	10' cable	24"	■		■		■		■			
SM800A-24-00	SM801A-24-10		12-24VDC	10' cable	24"	■	■			■				■	
SM800A-24-00FP	SM801A-24-10FP		12-24VDC	10' cable	24"	■			■	■				■	
SM800A-24-00S	SM801A-24-10S		12-24VDC	10' cable	24"	■		■		■				■	
SM800A-24-00	SM801A-24-11		12-24VDC	10' cable	24"	■	■			■					■
SM800A-24-00FP	SM801A-24-11FP		12-24VDC	10' cable	24"	■			■	■					■
SM800A-24-00S	SM801A-24-11S		12-24VDC	10' cable	24"	■		■		■					■
SM800A-24-02	SM801A-24-00		12-24VDC	10' cable	24"	■	■			■	■				
SM800A-24-02FP	SM801A-24-00FP		12-24VDC	10' cable	24"	■			■	■	■				
SM800A-24-02S	SM801A-24-00S		12-24VDC	10' cable	24"	■		■		■	■				

MICROSONIC® SM800 SERIES

# Selection Chart

## SM800 Series (cont.)

### MICROSONIC® Thru-Beam

Transmitter	Receiver	Model No.	Power Version	Connector Style	Sensing Range	Transducer				Housing				Transmitter			Receiver		
						Silicone*	18mm ULTEM®*	18mm Stainless	Flat-profile	Standard	Variable Power	Standard	Fast Response 4ms on & off	N.C. Output	N.C. Output Fast Response	Sensing Variations			
SM800A-24-02	SM801A-24-01		12-24VDC	10' cable	24"	■	■			■	■	■	■						
SM800A-24-02FP	SM801A-24-01FP		12-24VDC	10' cable	24"	■			■	■	■	■	■						
SM800A-24-02S	SM801A-24-01S		12-24VDC	10' cable	24"	■		■		■	■	■	■						
SM800A-24-02	SM801A-24-10		12-24VDC	10' cable	24"	■	■			■	■	■	■			■			
SM800A-24-02FP	SM801A-24-10FP		12-24VDC	10' cable	24"	■			■	■	■	■	■			■			
SM800A-24-02S	SM801A-24-10S		12-24VDC	10' cable	24"	■		■		■	■	■	■			■			
SM800A-24-02	SM801A-24-11		12-24VDC	10' cable	24"	■	■			■	■	■	■				■		
SM800A-24-02FP	SM801A-24-11FP		12-24VDC	10' cable	24"	■			■	■	■	■	■				■		
SM800A-24-02S	SM801A-24-11S		12-24VDC	10' cable	24"	■		■		■	■	■	■				■		
SM800A-40-00	SM801A-40-00		12-24VDC	10' cable	40"	■	■			■	■	■	■						
SM800A-40-00FP	SM801A-40-00FP		12-24VDC	10' cable	40"	■			■	■	■	■	■						
SM800A-40-00S	SM801A-40-00S		12-24VDC	10' cable	40"	■		■		■	■	■	■						
SM800A-40-00	SM801A-40-01		12-24VDC	10' cable	40"	■	■			■	■	■	■			■			
SM800A-40-00FP	SM801A-40-01FP		12-24VDC	10' cable	40"	■			■	■	■	■	■			■			
SM800A-40-00S	SM801A-40-01S		12-24VDC	10' cable	40"	■		■		■	■	■	■			■			
SM800A-40-00	SM801A-40-10		12-24VDC	10' cable	40"	■	■			■	■	■	■			■			
SM800A-40-00FP	SM801A-40-10FP		12-24VDC	10' cable	40"	■			■	■	■	■	■			■			
SM800A-40-00S	SM801A-40-10S		12-24VDC	10' cable	40"	■		■		■	■	■	■			■			
SM800A-40-00	SM801A-40-11		12-24VDC	10' cable	40"	■	■			■	■	■	■				■		
SM800A-40-00FP	SM801A-40-11FP		12-24VDC	10' cable	40"	■			■	■	■	■	■				■		
SM800A-40-00S	SM801A-40-11S		12-24VDC	10' cable	40"	■		■		■	■	■	■				■		
SM800A-40-02	SM801A-40-00		12-24VDC	10' cable	40"	■	■			■	■	■	■						
SM800A-40-02FP	SM801A-40-00FP		12-24VDC	10' cable	40"	■			■	■	■	■	■						
SM800A-40-02S	SM801A-40-00S		12-24VDC	10' cable	40"	■		■		■	■	■	■						
SM800A-40-02	SM801A-40-01		12-24VDC	10' cable	40"	■	■			■	■	■	■			■			
SM800A-40-02FP	SM801A-40-01FP		12-24VDC	10' cable	40"	■			■	■	■	■	■			■			
SM800A-40-02S	SM801A-40-01S		12-24VDC	10' cable	40"	■		■		■	■	■	■			■			
SM800A-40-02	SM801A-40-10		12-24VDC	10' cable	40"	■	■			■	■	■	■			■			
SM800A-40-02FP	SM801A-40-10FP		12-24VDC	10' cable	40"	■			■	■	■	■	■			■			
SM800A-40-02S	SM801A-40-10S		12-24VDC	10' cable	40"	■		■		■	■	■	■			■			
SM800A-40-02	SM801A-40-11		12-24VDC	10' cable	40"	■	■			■	■	■	■				■		
SM800A-40-02FP	SM801A-40-11FP		12-24VDC	10' cable	40"	■			■	■	■	■	■				■		
SM800A-40-02S	SM801A-40-11S		12-24VDC	10' cable	40"	■		■		■	■	■	■				■		
SM850A-04-00	SM851A-04-00		12-24VDC	Micro connector	4"	■	■			■	■	■	■						
SM850A-04-00FP	SM851A-04-00FP		12-24VDC	Micro connector	4"	■			■	■	■	■	■						
SM850A-04-00S	SM851A-04-00S		12-24VDC	Micro connector	4"	■		■		■	■	■	■						
SM850A-04-00	SM851A-04-01		12-24VDC	Micro connector	4"	■	■			■	■	■	■			■			
SM850A-04-00FP	SM851A-04-01FP		12-24VDC	Micro connector	4"	■			■	■	■	■	■			■			
SM850A-04-00S	SM851A-04-01S		12-24VDC	Micro connector	4"	■		■		■	■	■	■			■			
SM850A-04-00	SM851A-04-10		12-24VDC	Micro connector	4"	■	■			■	■	■	■			■			
SM850A-04-00FP	SM851A-04-10FP		12-24VDC	Micro connector	4"	■			■	■	■	■	■			■			
SM850A-04-00S	SM851A-04-10S		12-24VDC	Micro connector	4"	■		■		■	■	■	■			■			
SM850A-04-00	SM851A-04-11		12-24VDC	Micro connector	4"	■	■			■	■	■	■				■		
SM850A-04-00FP	SM851A-04-11FP		12-24VDC	Micro connector	4"	■			■	■	■	■	■				■		
SM850A-04-00S	SM851A-04-11S		12-24VDC	Micro connector	4"	■		■		■	■	■	■				■		
SM850A-04-02	SM851A-04-00		12-24VDC	Micro connector	4"	■	■			■	■	■	■						
SM850A-04-02FP	SM851A-04-00FP		12-24VDC	Micro connector	4"	■			■	■	■	■	■						
SM850A-04-02S	SM851A-04-00S		12-24VDC	Micro connector	4"	■		■		■	■	■	■						
SM850A-04-02	SM851A-04-01		12-24VDC	Micro connector	4"	■	■			■	■	■	■			■			
SM850A-04-02FP	SM851A-04-01FP		12-24VDC	Micro connector	4"	■			■	■	■	■	■			■			
SM850A-04-02S	SM851A-04-01S		12-24VDC	Micro connector	4"	■		■		■	■	■	■			■			
SM850A-04-02	SM851A-04-10		12-24VDC	Micro connector	4"	■	■			■	■	■	■			■			
SM850A-04-02FP	SM851A-04-10FP		12-24VDC	Micro connector	4"	■			■	■	■	■	■			■			
SM850A-04-02S	SM851A-04-10S		12-24VDC	Micro connector	4"	■		■		■	■	■	■			■			
SM850A-04-02	SM851A-04-11		12-24VDC	Micro connector	4"	■	■			■	■	■	■				■		
SM850A-04-02FP	SM851A-04-11FP		12-24VDC	Micro connector	4"	■			■	■	■	■	■				■		
SM850A-04-02S	SM851A-04-11S		12-24VDC	Micro connector	4"	■		■		■	■	■	■				■		
SM850A-12-00	SM851A-12-00		12-24VDC	Micro connector	12"	■	■			■	■	■	■						
SM850A-12-00FP	SM851A-12-00FP		12-24VDC	Micro connector	12"	■			■	■	■	■	■						
SM850A-12-00S	SM851A-12-00S		12-24VDC	Micro connector	12"	■		■		■	■	■	■						
SM850A-12-00	SM851A-12-01		12-24VDC	Micro connector	12"	■	■			■	■	■	■			■			
SM850A-12-00FP	SM851A-12-01FP		12-24VDC	Micro connector	12"	■			■	■	■	■	■			■			

# Selection Chart

## SM800 Series (cont.)

### MICROSONIC® Thru-Beam

Transmitter	Receiver	Model No.	Power Version	Connecton Style	Sensing Range	Transducer				Materials		Housing		Transmitter		Sensing Variations		Receiver	
						Silicone*	18mm ULTEM®*	18mm Stainless	Flat-profile	Standard	Variable Power	Standard	Fast Response 4ms on & off	N.C. Output	N.C. Output Fast Response				
SM850A-12-00S	SM851A-12-01S		12-24VDC	Micro connector	12"	■		■		■						■			
SM850A-12-00	SM851A-12-10		12-24VDC	Micro connector	12"	■	■			■								■	
SM850A-12-00FP	SM851A-12-10FP		12-24VDC	Micro connector	12"	■			■	■								■	
SM850A-12-00S	SM851A-12-10S		12-24VDC	Micro connector	12"	■		■		■								■	
SM850A-12-00	SM851A-12-11		12-24VDC	Micro connector	12"	■	■			■									■
SM850A-12-00FP	SM851A-12-11FP		12-24VDC	Micro connector	12"	■			■	■									■
SM850A-12-00S	SM851A-12-11S		12-24VDC	Micro connector	12"	■		■		■									■
SM850A-12-02	SM851A-12-00		12-24VDC	Micro connector	12"	■	■				■	■							
SM850A-12-02FP	SM851A-12-00FP		12-24VDC	Micro connector	12"	■			■	■									
SM850A-12-02S	SM851A-12-00S		12-24VDC	Micro connector	12"	■		■		■	■								
SM850A-12-02	SM851A-12-01		12-24VDC	Micro connector	12"	■	■			■									
SM850A-12-02FP	SM851A-12-01FP		12-24VDC	Micro connector	12"	■			■	■									
SM850A-12-02S	SM851A-12-01S		12-24VDC	Micro connector	12"	■		■		■	■								
SM850A-12-02	SM851A-12-10		12-24VDC	Micro connector	12"	■	■			■									
SM850A-12-02FP	SM851A-12-10FP		12-24VDC	Micro connector	12"	■			■	■									
SM850A-12-02S	SM851A-12-10S		12-24VDC	Micro connector	12"	■		■		■	■								
SM850A-12-02	SM851A-12-11		12-24VDC	Micro connector	12"	■	■			■									
SM850A-12-02FP	SM851A-12-11FP		12-24VDC	Micro connector	12"	■			■	■									
SM850A-12-02S	SM851A-12-11S		12-24VDC	Micro connector	12"	■		■		■	■								
SM850A-24-00•	SM851A-24-00•		12-24VDC	Micro connector	24"	■	■			■									
SM850A-24-00FP•	SM851A-24-00FP•		12-24VDC	Micro connector	24"	■			■	■									
SM850A-24-00S•	SM851A-24-00S•		12-24VDC	Micro connector	24"	■		■		■	■								
SM850A-24-00	SM851A-24-01		12-24VDC	Micro connector	24"	■	■			■									
SM850A-24-00FP	SM851A-24-01FP		12-24VDC	Micro connector	24"	■			■	■									
SM850A-24-00S	SM851A-24-01S		12-24VDC	Micro connector	24"	■		■		■	■								
SM850A-24-00	SM851A-24-10		12-24VDC	Micro connector	24"	■	■			■									
SM850A-24-00FP	SM851A-24-10FP		12-24VDC	Micro connector	24"	■			■	■									
SM850A-24-00S	SM851A-24-10S		12-24VDC	Micro connector	24"	■		■		■	■								
SM850A-24-00	SM851A-24-11		12-24VDC	Micro connector	24"	■	■			■									
SM850A-24-00FP	SM851A-24-11FP		12-24VDC	Micro connector	24"	■			■	■									
SM850A-24-00S	SM851A-24-11S		12-24VDC	Micro connector	24"	■		■		■	■								
SM850A-24-02	SM851A-24-00		12-24VDC	Micro connector	24"	■	■			■	■								
SM850A-24-02FP	SM851A-24-00FP		12-24VDC	Micro connector	24"	■			■	■									
SM850A-24-02S	SM851A-24-00S		12-24VDC	Micro connector	24"	■		■		■	■								
SM850A-24-02	SM851A-24-01		12-24VDC	Micro connector	24"	■	■			■									
SM850A-24-02FP	SM851A-24-01FP		12-24VDC	Micro connector	24"	■			■	■									
SM850A-24-02S	SM851A-24-01S		12-24VDC	Micro connector	24"	■		■		■	■								
SM850A-24-02	SM851A-24-10		12-24VDC	Micro connector	24"	■	■			■									
SM850A-24-02FP	SM851A-24-10FP		12-24VDC	Micro connector	24"	■			■	■									
SM850A-24-02S	SM851A-24-10S		12-24VDC	Micro connector	24"	■		■		■	■								
SM850A-24-02	SM851A-24-11		12-24VDC	Micro connector	24"	■	■			■									
SM850A-24-02FP	SM851A-24-11FP		12-24VDC	Micro connector	24"	■			■	■									
SM850A-24-02S	SM851A-24-11S		12-24VDC	Micro connector	24"	■		■		■	■								
SM850A-40-00•	SM851A-40-00•		12-24VDC	Micro connector	40"	■	■			■									
SM850A-40-00FP•	SM851A-40-00FP•		12-24VDC	Micro connector	40"	■			■	■									
SM850A-40-00S•	SM851A-40-00S•		12-24VDC	Micro connector	40"	■		■		■	■								
SM850A-40-00	SM851A-40-01		12-24VDC	Micro connector	40"	■	■			■									
SM850A-40-00FP	SM851A-40-01FP		12-24VDC	Micro connector	40"	■			■	■									
SM850A-40-00S	SM851A-40-01S		12-24VDC	Micro connector	40"	■		■		■	■								
SM850A-40-00	SM851A-40-10		12-24VDC	Micro connector	40"	■	■			■									
SM850A-40-00FP	SM851A-40-10FP		12-24VDC	Micro connector	40"	■			■	■									
SM850A-40-00S	SM851A-40-10S		12-24VDC	Micro connector	40"	■		■		■	■								
SM850A-40-00	SM851A-40-11		12-24VDC	Micro connector	40"	■	■			■									
SM850A-40-00FP	SM851A-40-11FP		12-24VDC	Micro connector	40"	■			■	■									
SM850A-40-00S	SM851A-40-11S		12-24VDC	Micro connector	40"	■		■		■	■								
SM850A-40-02	SM851A-40-00		12-24VDC	Micro connector	40"	■	■			■	■								
SM850A-40-02FP	SM851A-40-00FP		12-24VDC	Micro connector	40"	■			■	■									
SM850A-40-02S	SM851A-40-00S		12-24VDC	Micro connector	40"	■		■		■	■								
SM850A-40-02	SM851A-40-01		12-24VDC	Micro connector	40"	■	■			■									
SM850A-40-02FP	SM851A-40-01FP		12-24VDC	Micro connector	40"	■			■	■									
SM850A-40-02S	SM851A-40-01S		12-24VDC	Micro connector	40"	■		■		■	■								
SM850A-40-02	SM851A-40-10		12-24VDC	Micro connector	40"	■	■			■									
SM850A-40-02FP	SM851A-40-10FP		12-24VDC	Micro connector	40"	■			■	■									

MICROSONIC® SM800 SERIES

# Selection Chart

## SM800 Series (cont.)

### MICROSONIC® Thru-Beam

Transmitter	Receiver	Model No.	Power Version	Connecton Style	Sensing Range	Transducer				Housing				Transmitter		Sensing Variations			Receiver	
						Silicone*	18mm ULTEM®*	18mm Stainless	Flat-profile	Standard	Variable Power	Standard	Fast Response	.4ms on & off	N.C. Output	N.C. Output	Fast Response			
SM850A-40-02S	SM851A-40-10S		12-24VDC	Micro connector	40"	■		■			■							■		
SM850A-40-02	SM851A-40-11		12-24VDC	Micro connector	40"	■	■				■								■	
SM850A-40-02FP	SM851A-40-11FP		12-24VDC	Micro connector	40"	■			■		■								■	
SM850A-40-02S	SM851A-40-11S		12-24VDC	Micro connector	40"	■		■			■								■	

• = Most commonly stocked sensors  
 \* = See definition in Sensing Terms.  
 All possible sensor configurations are not listed here.



## Microsonic® Thru-Beam Web Sensing System

*Web inspecting  
applications*



This innovative sensing solution is applicable to industries that convert plies of materials into embossed napkins, paper towels, plastic-lined paper table cloths, and other consumer products. The Model SS100 Web Sensing System uses MICROSONIC®, thru-beam sensors to eliminate the costly problem of broken plies wrapping around, heating up, and damaging embossing rolls, as well as the resulting downtime required to make necessary repairs. False trips or no trips at all resulting from dusty environments, or problems associated with sensors not immune to changing colors and materials, are also eliminated.

### **What does the SS100 Web Sensing System do?**

Equipped with up to three pairs (transmitter and receiver) of MICROSONIC®, thru-beam sensors, the SS100 system monitors the entire width of the embossed web as it leaves the embossing rolls. Machine speeds in excess of 26 feet per second as well as dust, different colors and textures have no effect on the sensing capability

of these sensors. During operation, when one of the sensors detects a tear in the web, a missing ply or even a hole in the web of predetermined size, the SS100 system immediately outputs an alarm signal. The signal can be used to alert an operator, automatically shear the paper ahead of the embossing rolls, or automatically stop the machine. As a result, the embossing rolls are saved from severe damage and time-consuming repairs. After the web is rethreaded, the embossing part of the operation can resume.

Using the amount of sound energy transmitted through the plies of material to calibrate the system and detect the breaks, the SS100 system operates on a supply voltage of 85 to 270 VAC (50/60 Hz). The supply current ranges from 10 to 40 (typical) mA. Three push-buttons are provided to calibrate the detector, set and reset the indications of a ply break, and view and sometimes change the various settings. A digital display provides various information on each of the sensor pair channels and a numeric display shows, sequentially, the signal strength

- *Eliminates damage to embossing rolls*
- *Monitors the entire width of the embossed web as it leaves the embossing rolls*
- *Alarm signal can alert operator, automatically shear the paper ahead of the embossing roll, or automatically stop the machine*
- *Uses up to three pairs (transmitter/receiver) of MICROSONIC® ultrasonic thru-beam sensors*

## How does it work?

Ultrasonic energy can be transmitted through certain materials, even numerous plies of paper. With the SS100, the user calibrates the amount of energy passing through the plies. This calibration automatically adjusts the gain to obtain an output which is about 25% of full scale. Because many factors can affect the transmission through the good plies of paper, a threshold percentage is set which is then automatically adjusted to track the average signal transmitted through the paper. For example, say the calibrated gain for three plies of embossed paper being run is 25%. With a threshold setting of 10% if the variation readings are continuously above the threshold level of 35% (25% + 10%), the SS100 signals a break. A second setting available to signal a break involves the minimum duration of time (displayed in hundredths of a second) the variation readings are continuously above the threshold level. A third setting, minimum length, is the distance traveled by the plies (displayed in pulses of the position sensor) when the readings are continuously above the threshold level.

For the user's convenience, the SS100 Web Sensing System provides:

- three push-buttons (CALIBRATE, VIEW SETTINGS, RESET INDICATORS) to calibrate the detector, set and reset the indications (minimum duration and minimum length) of a ply break and view and sometimes change the various settings.

- a digital display for various information on each of the sensor pair channels. The numeric display shows, sequentially, the signal strength and signal variation for each channel.

- an LED for each transmitter/receiver pair to indicate the operational status of the particular sensor pair during operation. For example, solid green means normal operation; solid red means this particular transmitter/receiver pair has detected a ply breakage.

**Hyde Park also offers an SS100-13 Splice Sensing System which uses the same operating principle as the SS100 Web Sensing System.**

## Specifications

PARAMETER	Minimum	Maximum
-----------	---------	---------

### Environmental

Operating Temperature	5°C (40°F)	50°C(120°F)
Operating Humidity	10%	90% (non condensing)

### Power

Supply Voltage	85VAC (50/60 Hz)	270 VAC (50/60 Hz)
Supply Current	10 mA	140 mA (typical)

### Physical

Weight	0.5Kg (1.1 lbs)
Depth	21 mm (0.825 in) top to panel
Height	159 mm (6.25 in) bottom to top of mounting
Width	210 mm (8.25 in) side to side of mounting panel

## External Connections

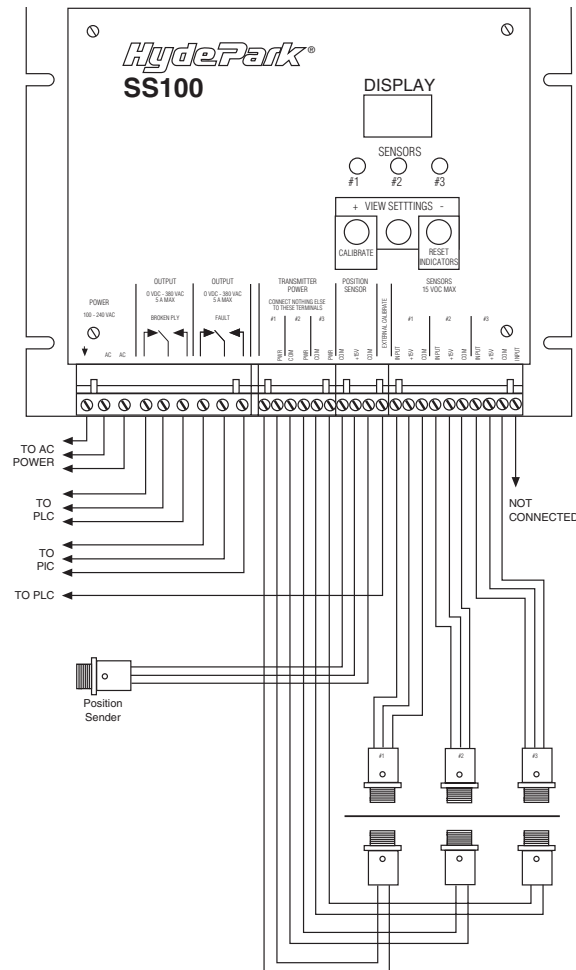



patent pending

## **A cost-effective power and output conversion accessory for DC sensors...**

Python Power is an accessory that allows a DC sensor to be installed in locations where only AC power is available or to simply maximize installation efficiency.

Python consists of a universal, in-line AC/DC power supply and TRIAC switch. The integral TRIAC output switch is controlled by the sensor's low-voltage output, automatically detecting a sinking or sourcing output. The TRIAC is then actuated.

The DC output will power most types of sensors, allowing users to take advantage of the advanced features available in DC sensors that are not available in AC sensors. Unlike other products, Python has a sleek design and can be pulled through and stored in a 1-inch straight conduit.

Python is a powerful performer and an ideal converter for retro-fit installations.

Accepting universal AC input voltages from 85VAC to 265VAC, the encapsulated housing and integral cables are resistant to most acids, bases, and food and beverage.

Python is UL listed to UL61010C-1 and CE certified to EN61010C-1. Python's IP67 enclosure rating ensures it will withstand washdown environments.

Python supports many sensing applications where DC power is unavailable. Because of this versatility, it is a solid candidate for almost every application in an AC environment. Python is an ideal converter for retro-fit installations and a cost-effective, time-saving solution for new installations. Python accommodates all Hyde Park DC-powered sensors, as well as most other brands. Python can be used with most any sensing technology, including ultrasonic, photoelectric, and inductive proximity.

## *PYTHON POWER™*

### *AC/DC Power Supply/ Output Converter*

- *Self-contained, AC/DC power converter*
- *Integral isolated TRIAC output*
- *Sleek design*
- *Stored in or pulled through a 1" straight conduit*
- *IP67 enclosure rating*
- *CE certified*



## Operation

Depending on the type of sensor you are using, Python's model number will vary (see Model Reference Guide on page 6-3). The sensor you are using must operate on a 15VDC to 18VDC supply, consume 100mA or less of operating current, and have a sink or source output.

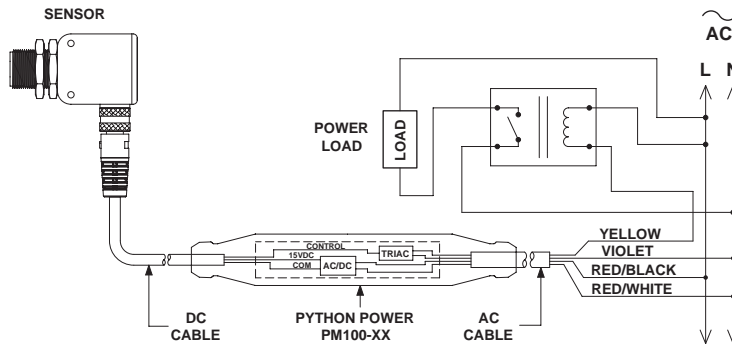

**DRIVING POWER RELAY**

**WARNING:** Applied AC load must limit Python's TRIAC switch to rated current.

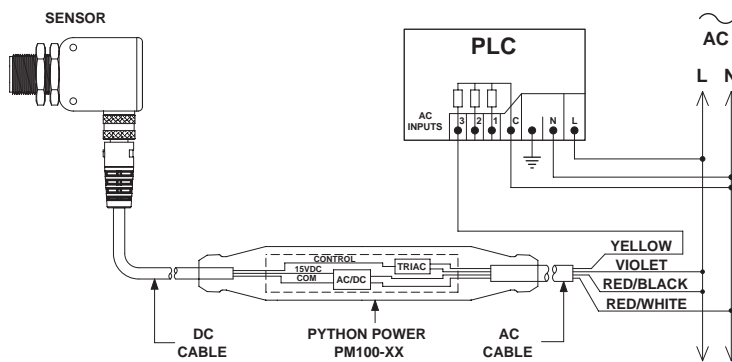

**TYPICAL PLC CONNECTION**

**WARNING:** Applied AC load must limit Python's TRIAC switch to rated current.

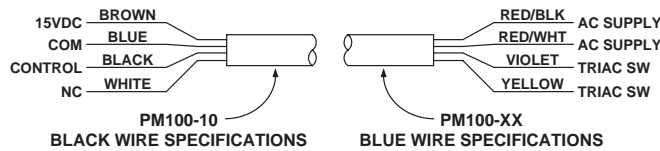

## Dimensions

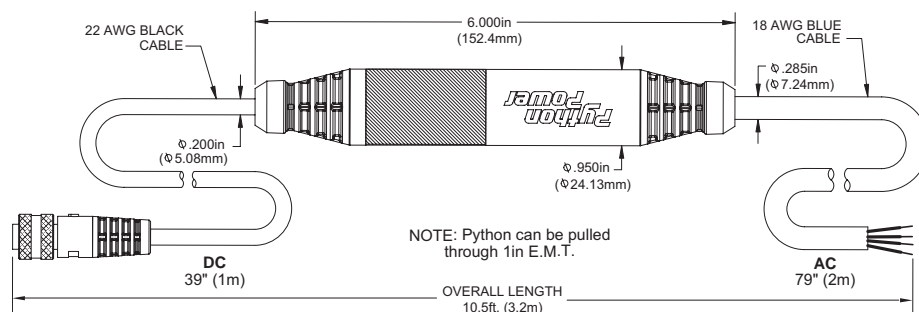

## Model Reference Guide - Python Power

Model	Connector	Female Contacts	Pinout, sensor connector
PM100-00	M8	3	
PM100-01	M8	4	
PM100-02	M12	4	
PM100-03	M12 Green LED - Power Amber LED - Output (sink)	4	
PM100-04	Mini (7/8-11 thread)	4	
PM100-10	No connector	n/a	

## General Specifications

### AC Power Requirements

Supply Voltage:  
85VAC to 265VAC, 50/60Hz  
Current Consumption:  
35 mA max.  
Power Consumption:  
4 VA max.  
Installation category: II (IEC 60364-4-443)  
Input fusing: non-replaceable, non-repairable

### DC Output Ratings (to sensor)

Output voltage:  
Minimum at rated current: 15VDC  
Maximum at no load: 20VDC  
Regulation: 40 V/A  
Current, max. rated: 100mA  
Current fault, max.: 200 mA  
Pri/sec. isolation: 2200VAC, 1 min.  
Turn-on delay, 100mA load, 90% final voltage: 10ms typical  
Turn-off delay, 0mA load, 10% full voltage: 1s typical

### TRIAC Switch Ratings (switch AC current only)

Features: optically isolated, zero-crossing  
Switch voltage, maximum: 230VAC  
Switch Current, maximum: 50mA@230VAC, 100mA@120VAC  
Isolated from AC line

Peak repetitive surge current: 1 A (100 $\mu$ s, 120pps)  
On-state voltage: 3v max, @ 100 mA  
Off-state leakage: 500nA max.  
Holding current: 250 $\mu$ A typical  
Critical rate of rise of off-state voltage: 600v/us min.  
Isolation surge voltage: 7500VAC min., 60Hz, 1 sec.  
Turn-on time, full load, max voltage: 15ms max. (zero-crossing)  
Turn-off time, full load, max voltage: 15ms max. (zero-crossing)  
Over-current protection: internal fuse (non-replaceable, non-repairable)

### Environmental

Operating Temperature Range:  
-25° to 60°C (-13° to 140°F)  
Storage Temperature Range:  
-40° to 85°C (-40° to 185°F)  
Operating Humidity: 100%, non-condensing  
Protection Ratings: Type 1 (UL50), IP67

### Agency Approvals

CE Mark: CE conformity is declared to:  
EN55011:1998 Group 1, Class A  
EN61010C-1  
EMC: EN61326:1997 Measur., Lab., and Control  
FCC Class A (USA)  
UL61010C-1 "Industrial Control Equipment"  
File#E238344  
FDA: Cables and over-mold are FDA compatible non-contact  
*Declaration of Conformity available upon request*

### Construction

Dimensions: (length x diameter)  
152 mm (6.0 in) x 24 mm (0.95 in)  
AC cable: 4-wire, 18AWG, 300V, PVC:  
2 m (79.0 in) x 7 mm (0.28 in) dia.  
DC cable: 4-wire, 22AWG, 300V, PVC  
1 m (39.0 in) x 5.2 mm (0.21 in) dia.  
Material: PVC  
Input fusing: non-replaceable, non-repairable

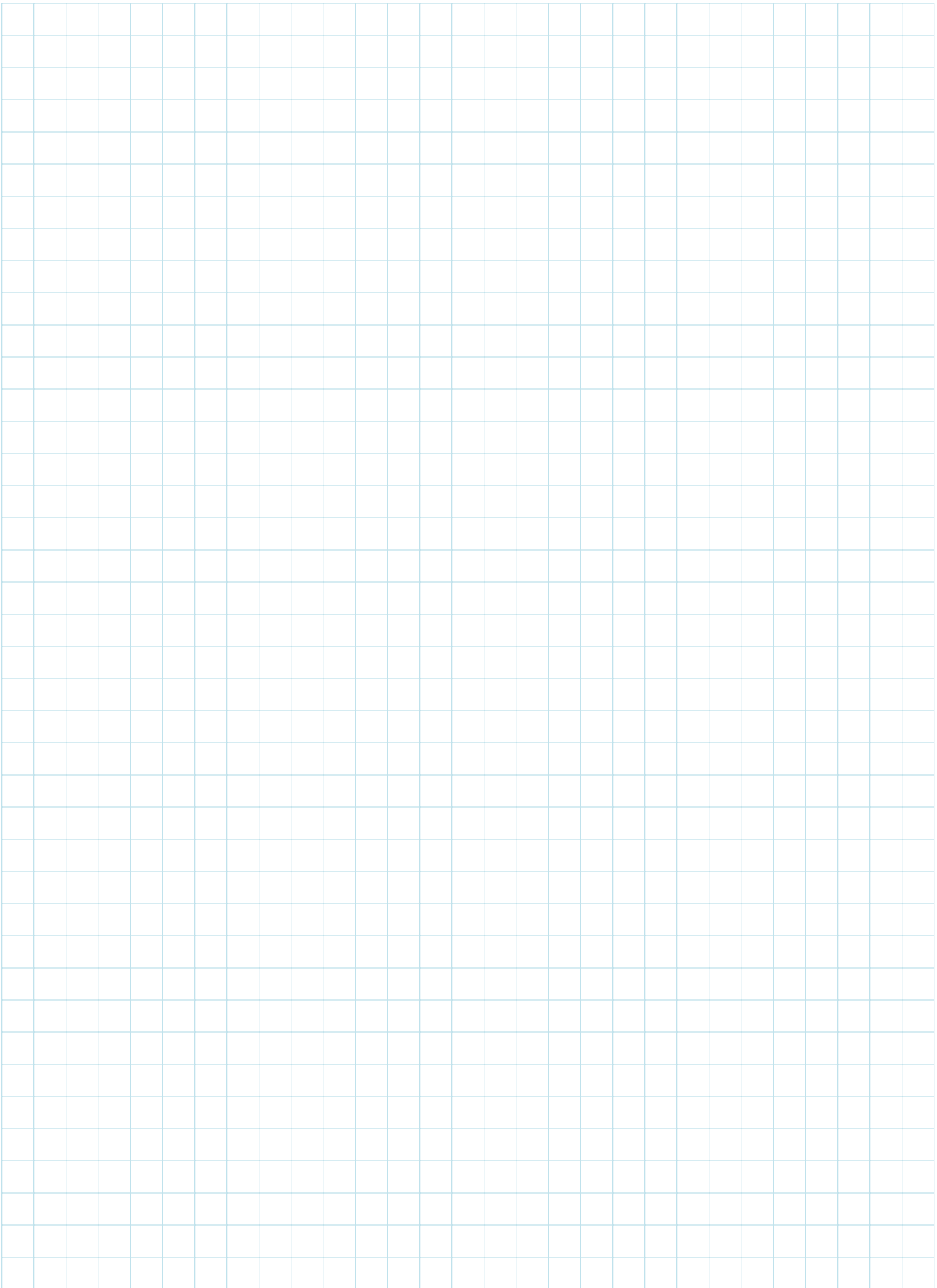



**Model AC100**

2-conductor, transmitter connector cable, 3 m (10'), for all MICROSONIC® SM100 series Amphenol and SM700 series Amphenol connector-style, thru-beam transmitters



**Model AC105**

Straight, 7/8-16 mini, 4-conductor, mating connector cable, 4 m (12'), used with SUPERPROX® SM500 family connector-style, prox sensors



**Model AC105-50**

Straight, 7/8-16 mini, 4-conductor, mating connector cable, 15 m (50'), used with all SUPERPROX® SM500 family connector-style, prox sensors



**Model AC107**

Straight, 7/8-16 mini, 2-pin, 2-conductor, mating connector cable, 4 m (12'), used with all MICROSONIC® SM100 series watertight and SM700 series watertight, connector-style, thru-beam transmitters



**Model AC108**

Straight, 7/8-16 mini, 3-pin, 3-conductor, mating connector cable, 4 m (12'), used with all MICROSONIC® SM100 series watertight and SM700 series watertight, connector-style, thru-beam receivers



**Model AC115**

Straight, 7/8-16 mini, 5-conductor, mating connector cable, 4 m (12'), used with SUPERPROX® SM552A-X7X series dual-level, connector-style, prox sensors with alarms, SM554B-XXX series synchronized/gate-controlled, connector-style, prox sensors and SM556A-X9X series analog, connector-style, prox sensors with alarms



**Model AC115-50**

Straight, 7/8-16 mini, 5-conductor, mating connector cable, 15 m (50'), used with SUPERPROX® SM552A-X7X series dual-level, connector-style, prox sensors with alarms, SM554B-XXX series synchronized/gate-controlled, connector-style, prox sensors and SM556A-X9X series analog, connector-style, prox sensors with alarms



**Model AC117**

Right-angle, M12 micro, 4-conductor, connector/cable assembly with built-in LEDs, 5 m (16'), used with SUPERPROX® SM650 series and SM657 series miniature prox sensors and MICROSONIC® SM851 series miniature, connector-style, thru-beam receivers



**Model AC118**

Right-angle, M12 micro, 2-conductor, connector/cable assembly, 5 m (16'), used with MICROSONIC® SM850 series miniature, connector-style, thru-beam transmitters



**Model AC119**

Right-angle, M12 micro, 4-conductor, connector/cable assembly, 5 m (16'), with built-in LEDs used with SUPERPROX® SM656 series miniature, connector-style, analog prox sensors



**Model AC127**

Straight, M12 micro, 4-conductor, connector/cable assembly with LED, 5 m (16'), with LEDs, used with SUPERPROX® SM650 series and SM657 series miniature, connector-style prox sensors and MICROSONIC® SM851 series connector-style, thru-beam receivers



**Model AC128**

Straight, M12 micro, 4-pin, 2-conductor, connector/cable assembly, 5 m (16'), used with MICROSONIC® SM850 series miniature, connector-style, thru-beam transmitters and SM850FP series miniature, flat-profile, connector-style, thru-beam transmitters



**Model AC129**

Straight, M12 micro, 4-conductor, connector/cable assembly, 5 m (16'), with LEDs used with SUPERPROX® SM656 series miniature, connector-style, analog prox sensors





**Model AC130**

Straight, M12 micro, 4-conductor, connector/cable assembly, 5 m (16'), used with SUPERPROX® SM650FP, SM656FP, SM657FP, SM950, SM952, SM956 and CT1500 series sensors, connector style, and MICROSONIC® SM851FP series thru-beam receivers, connector style



**Model AC138**

Pico-to-micro pigtail adapter cable with reversed output pins, 0.2 m (7.9"), used with all SUPERPROX® SM350 series proximity sensors

**Model AC145**

Right-angle, M8 pico, 4-pin, 2-conductor, connector/cable assembly, 5 m (16') for SM450 connector-style transmitters



**Model AC132**

Right-angle, M12 micro, 4-conductor, connector/cable assembly, 5 m (16'), used with SUPERPROX® SM950, SM952, SM956 and CT1500 series sensors, connector

**Model AC140**

Mini-to-micro 4-conductor pigtail adapter cable, 0.2 m (7.9"). Used with all SM600 series proximity sensors.



**Model AC146**

Straight, M8 pico, 4-pin, 2-conductor, connector/cable assembly, 5 m (16') for SM 450 connector-style transmitters



**Model AC134**

Right-angle, M8 pico, 4-conductor, connector/cable assembly, 5 m (16'), used with all SUPERPROX® SM350 series proximity sensors



**Model AC141**

Right-angle, M8 pico, 3-conductor, connector/cable assembly, 5 m (16'), used with all SUPERPROX® SM330 and SM340 series proximity sensors



**Model AC149**

Straight, 5 conductor/cable assembly, 2 m (6.6"). Used with SM650 with "AA" option, SM652 with "AA" option, and SM900 series with connector and "AA" option.



**Model AC135**

Straight, M8 pico, 4-conductor, connector/cable assembly, 5 m (16'), used with all SUPERPROX® SM350 series proximity sensors



**Model AC142**

Straight, M8 pico, 3-conductor, connector/cable assembly, 5 m (16'), used with all SUPERPROX® SM330 and SM340 series proximity sensors



**Model AC150**

3-conductor connector cable, 3 m (10'), used with all MICROSONIC® SM100 series Amphenol and SM700 series Amphenol connector-style receivers



**Model AC136**

Straight, 5-pin M12 micro connector/cable assembly, 5 m (16') O.D.V.A. compliant. Used with DeviceNet sensors.



**Model AC143**

Right angle, M8 pico, 3-pin, 2-conductor, connector/cable assembly, 5 m (16') for SM430 connector-style transmitters



**Model AC160**

Cable Grip used with all MICROSONIC® SM100 and SM700 series cable-style, thru-beam sensors



**Model AC137**

Pico-to-micro pigtail adapter cable, 0.2 m (7.9"), used with all SUPERPROX® SM350 series proximity sensors



**Model AC144**

Straight, M8 pico, 3-pin, 2-conductor, connector/cable assembly, 5 m (16') for SM430 connector-style transmitters



**Model AC172**

DB9, RS232 straight-through cable, 2 m (6'), used with Model AC441A





**Model AC201**

Stainless, right-angle, single-thru-beam-sensor, mounting bracket, slotted for adjustment, for all MICROSONIC® SM100 series and SM700 series transmitters and receivers and CS107 Web Sensing System transmitter and CS108 Web Sensing System receiver



**Model AC227**

Large, right-angle, stainless, mounting bracket used with all SUPERPROX® SM600 series miniature, prox sensors and all MICROSONIC® SM800 series miniature, thru-beam sensors

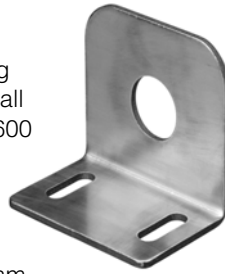

**Model AC232**

S-shaped, stainless, mounting bracket, with base slotted for sensor adjustment, used with all flat-profile sensors



**Model AC228**

Small, right-angle, stainless, mounting bracket used with all SUPERPROX® SM600 series miniature, prox sensors and all MICROSONIC® SM800 series miniature, thru-beam sensors



**Model AC233**

Small, right-angle, stainless, mounting bracket, with cable clearance slot, for all SUPERPROX® SM900



**Model AC222**

Standard, stainless mounting bracket assembly, slotted for vertical adjustment, used with all SUPERPROX® SM500 family prox sensors

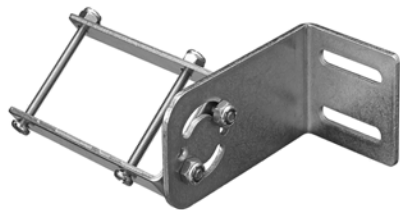

**Model AC229**

Plate-style, right-angle, stainless, mounting bracket, with base slotted for forward/reverse adjustment and side slotted for sensor adjustment, used with all SM500 family sensors



**Model AC234**

Right-angle, stainless, mounting bracket, used with all SUPERPROX® CT1000 series counting sensors

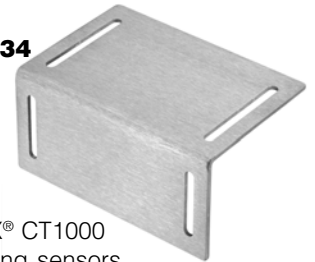

**Model AC213**

Stainless and Teflon, remote sensing probe mounting bracket, used with all SUPERPROX® SM500 family prox sensors and all MICROSONIC® SM700 series remote thru-beam transmitters and receivers



**Model AC230**

Three-piece, stainless mounting bracket assembly with O-ring mount used with all SUPERPROX® SM500 family sensors w/ remote heads

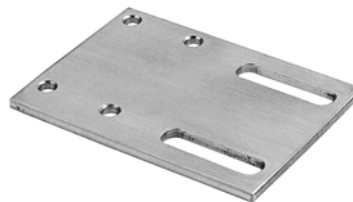

**Model AC235**

Right-angle, stainless, mounting bracket, used with all SUPERPROX® SM300 series proximity sensors



**Model AC226**

Stainless and polyamide conveyor-rail clamp/bracket set, used with all SUPERPROX® SM600 series miniature, prox sensors and MICROSONIC® SM800 series miniature thru-beam sensors



**Model AC231**

Straight, stainless, mounting bracket, with side slotted for sensor adjustment, used with all flat-profile sensors.



**Model AC236**

Stainless and polyamide conveyor-rail clamp/bracket set, used with all SUPERPROX® SM300 series proximity sensors

**Model AC237**

Straight, stainless mounting bracket, used with all SUPERPROX® SM300 series proximity sensors



**Model AC246**

Right-angle, stainless, mounting bracket, used with all SUPERPROX® SM300FP flat-profile series proximity sensors

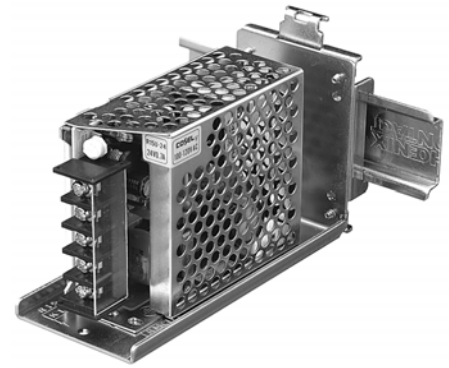

**Model AC439**

24 VDC Power Supply, 700 mA, with AC and DC screw terminals, used with all DC-powered Hyde Park sensors

**Model AC240**

Straight, stainless mounting bracket, used with all SUPERPROX® SM600 series proximity sensors



**Model AC247**

Stainless and polyamide conveyor-rail clamp/bracket set, used with all SUPERPROX® SM300FP series proximity sensors



**Model AC441A HANDHELD CONFIGURATOR**

Used, without a computer, to set window and span limits of 30 mm long-range discrete and analog sensors and display object distance, or with a computer to configure SC model sensors with SUPERPROX+ software



**Model AC241**

Steel/black oxide, 45° angle, label edge mounting bracket used with SUPERPROX® SM6X7A-A08-01FP or SM6X7A-A08-11FP flat-profile label sensors

**Model AC250-n**

Tank sensor mounting reducer, available with four different outside diameters; used with all SUPERPROX® SM900 family sensors. n = 1 (1 1/4" NPT); 2 (2" NPT); 3 (3" NPT); 4 (4" NPT)

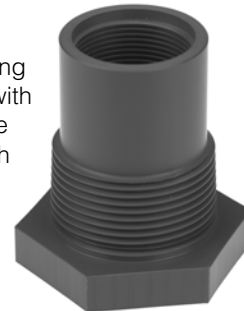

**Model PB100**

In-line accessory push-button for teaching window limits for Virtu series sensors.

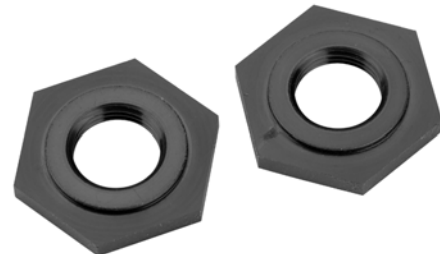

**Model AC242**

Pair of hex nuts for adapting all 12 mm diameter SUPERPROX® SM300 series proximity sensors to 18 mm diameter mounting bracket

**Model AC243**

Pair of hex nuts for adapting all 12 mm diameter SUPERPROX® SM300 series proximity sensors to 30 mm diameter mounting bracket



**Model AC251-n**

Tank sensor mounting flange, available with three different pipe thread diameters, furnished with matching AC250 tank sensor mounting reducer; used with all SUPERPROX® SM900 family sensors. n = 2 (2" NPT); 3 (3" NPT); 4 (4" NPT)



# Need a sensing solution today? Fax Hyde Park Electronics for a recommendation.

**Fax No. (937) 258-5830**

(Copy this form in order to maintain the original in your catalog.)

To: 

From (Your Name): \_\_\_\_\_

Company: \_\_\_\_\_

Telephone No. (including Area Code): \_\_\_\_\_

Fax No. (including Area Code): \_\_\_\_\_

**Our problem is this:**

The environment in the immediate area is (dry, wet, dusty, humid, etc.):

What we need to accomplish is:

Here's a rough sketch (if helpful) of the machinery/equipment involved:

*I understand that asking for this recommendation involves no obligation of any kind.*



## Warranty Terms and Conditions

---

### **Limitations and Exclusions of Warranty**

All Goods purchased from Hyde Park Electronics LLC, shall be free from defects in the materials, design and workmanship under normal conditions of use for one year from the date of shipment. THIS WARRANTY IS THE SOLE WARRANTY AND IS EXPRESSLY IN LIEU OF ALL OTHER WARRANTIES EXPRESS OR IMPLIED, INCLUDING BUT NOT LIMITED TO ANY IMPLIED WARRANTY OF MERCHANTABILITY OF FITNESS FOR A PARTICULAR PURPOSE. THE LIABILITY OF HYDE PARK TO ANY PURCHASER SHALL BE LIMITED EXCLUSIVELY TO THE COST OF REPLACEMENT OR REPAIR OF DEFECTIVE PARTS, AND SHALL NOT INCLUDE LIABILITY FOR ANY DEFECTIVE PARTS, AND SHALL NOT INCLUDE LIABILITY FOR ANY DIRECT, CONSEQUENTIAL OR INCIDENTAL DAMAGES WHATSOEVER, WHETHER FORESEEN OR UNFORESEEN, INCLUDING BUT NOT LIMITED TO LOST PROFITS, LOST SALES, OR INJURY TO PERSONS OR PROPERTY.

### **Procedure for making a warranty claim**

- 1.** Contact the Hyde Park distributor from whom the product was purchased. If purchased directly from Hyde Park, call Hyde Park at (937) 252-2121.
- 2.** Obtain from either the distributor or Hyde Park a Return Authorization number.
- 3.** Return product, with the Return Authorization number, to the distributor or directly to Hyde Park at:  
Hyde Park Electronics LLC  
1875 Founders Drive  
Dayton, OH 45420-4017  
Attn: Service & Repair  
Department
- 4.** After confirming Warranty Applicability, the distributor or Hyde Park will determine the appropriate action to be taken.

**Reaching Across the Globe  
And Yet As Close As Your Phone**



**Continually Building a Distributor Network  
That Helps Meet Your Sensing Needs  
Where You Are.**

**Call Hyde Park for more information and for  
the contact information of your nearest distributor  
(937) 252-2121  
or go to our website at: [www.hpsensors.com](http://www.hpsensors.com)**



***Distributor Information:***

**Hyde Park Electronics LLC**

Corporate Headquarters  
1875 Founders Drive  
Dayton, Ohio 45420-4017, U.S.A.  
Phone: (937) 252-2121  
Fax: (937) 258-5830  
E-mail: [hydepark@hpsensors.com](mailto:hydepark@hpsensors.com)  
Web: [www.hpsensors.com](http://www.hpsensors.com)

**Hyde Park Canada**

Chartwell Electronics, Inc.  
140 Duffield Drive  
Markham, Ontario L6G 1B5  
Phone: (905) 513-7100  
Toll free: (877) 513-7769  
Fax: (905) 513-7101  
Web: [www.chartwell.ca](http://www.chartwell.ca)